

TROUBLE SHOOTING - BASIC PROCEDURES

1996 Toyota Supra

GENERAL TROUBLE SHOOTING

* PLEASE READ THIS FIRST *

NOTE: This is GENERAL information. This article is not intended to be specific to any unique situation or individual vehicle configuration. The purpose of this Trouble Shooting information is to provide a list of common causes to problem symptoms. For model-specific Trouble Shooting, refer to SUBJECT, DIAGNOSTIC, or TESTING articles available in the section(s) you are accessing.

ACCESSORIES & ELECTRICAL

CHARGING SYSTEM TROUBLE SHOOTING

NOTE: This is GENERAL information. This article is not intended to be specific to any unique situation or individual vehicle configuration. The purpose of this Trouble Shooting information is to provide a list of common causes to problem symptoms. For model-specific Trouble Shooting, refer to SUBJECT, DIAGNOSTIC, or TESTING articles available in the section(s) you are accessing.

BASIC CHARGING SYSTEM TROUBLE SHOOTING CHART

CONDITION	POSSIBLE CAUSE	CORRECTION
Vehicle Will Not Start	Dead battery	Check battery cells, alternator belt tension and alternator output
	Loose or corroded battery connections	Check all charging system connections
	Ignition circuit or switch malfunction	Check and replace as necessary
Alternator Light Stays On With Engine Running	Loose or worn alternator drive belt	Check alternator drive tension and condition, See Belt Adjustment in TUNE-UP article in the TUNE-UP section
	Loose alternator wiring connections	Check all charging system connections
	Short in alternator light wiring	See Indicator Warning Lights in STANDARD INSTRUMENTS in the ACCESSORIES & EQUIPMENT section
	Defective alternator stator or diodes	See Bench Tests in ALTERNATOR article
	Defective regulator	See Regulator Check in

		ALTERNATOR article
Alternator Light Stays Off With Ignition Switch ON	Blown fuse	See WIRING DIAGRAMS
	Defective alternator	See Testing in ALTERNATOR article
	Defective indicator light bulb or socket	See Indicator Warning Lights in STANDARD INSTRUMENTS in the ACCESSORIES & EQUIPMENT section
Alternator Light Stays OFF With Ignition Switch ON	Short in alternator wiring	See On-Vehicle Tests in ALTERNATOR article
	Defective rectifier bridge	See Bench Tests in ALTERNATOR article
Lights or Fuses Burn Out Frequently	Defective alternator wiring	See On-Vehicle Tests in ALTERNATOR article
	Defective regulator	See Regulator Check in ALTERNATOR article
	Defective battery	Check and replace as necessary
Ammeter Gauge Shows Discharge	Loose or worn drive belt	Check alternator drive belt tension and condition. See Belt Adjustment in TUNE-UP article in the TUNE-UP section
	Defective wiring	Check all wires and wire connections
	Defective alternator or regulator	See Bench Tests and On-Vehicle Tests in ALTERNATOR article
	Defective ammeter, or improper ammeter wiring connection	See Testing in STANDARD INSTRUMENTS in the ACCESSORIES & EQUIPMENT section
Noisy Alternator	Loose drive pulley	Tighten drive pulley attaching nut
	Loose mounting bolts	Tighten all alternator mounting bolts
	Worn or dirty bearings	See Bearing Replacement ALTERNATOR article

	Defective diodes or stator	See Bench Test in ALTERNATOR article
Battery Does Stay Charged	Loose or worn drive belt	Check alternator drive belt tension and condition. See Belt Adjustment in appropriate TUNE-UP article in the TUNE-UP section
	Loose or corroded battery connections	Check all charging system connections
	Loose alternator connections	Check all charging system connections
	Defective alternator or battery	See On-Vehicle Tests and Bench Tests in ALTERNATOR article
	Add-on electrical accessories exceeding alternator capacity	Install larger alternator
Battery Overcharged- Uses Too Much Water	Defective battery	Check alternator output and repair as necessary
	Defective alternator	See On-Vehicle Test and Bench Tests in ALTERNATOR article
	Excessive alternator voltage	Check alternator output and repair as necessary

IGNITION SYSTEM TROUBLE SHOOTING

NOTE: This is GENERAL information. This article is not intended to be specific to any unique situation or individual vehicle configuration. The purpose of this Trouble Shooting information is to provide a list of common causes to problem symptoms. For model-specific Trouble Shooting, refer to SUBJECT, DIAGNOSTIC, or TESTING articles available in the section(s) you are accessing.

Ignition Secondary Trouble Shooting Chart

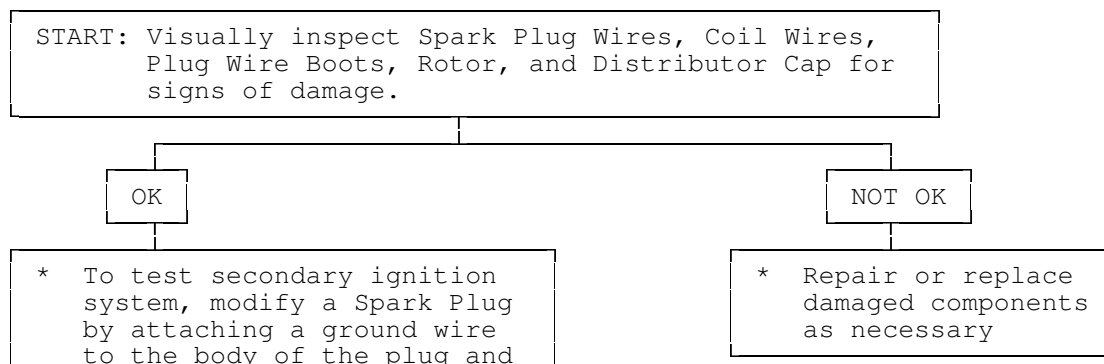

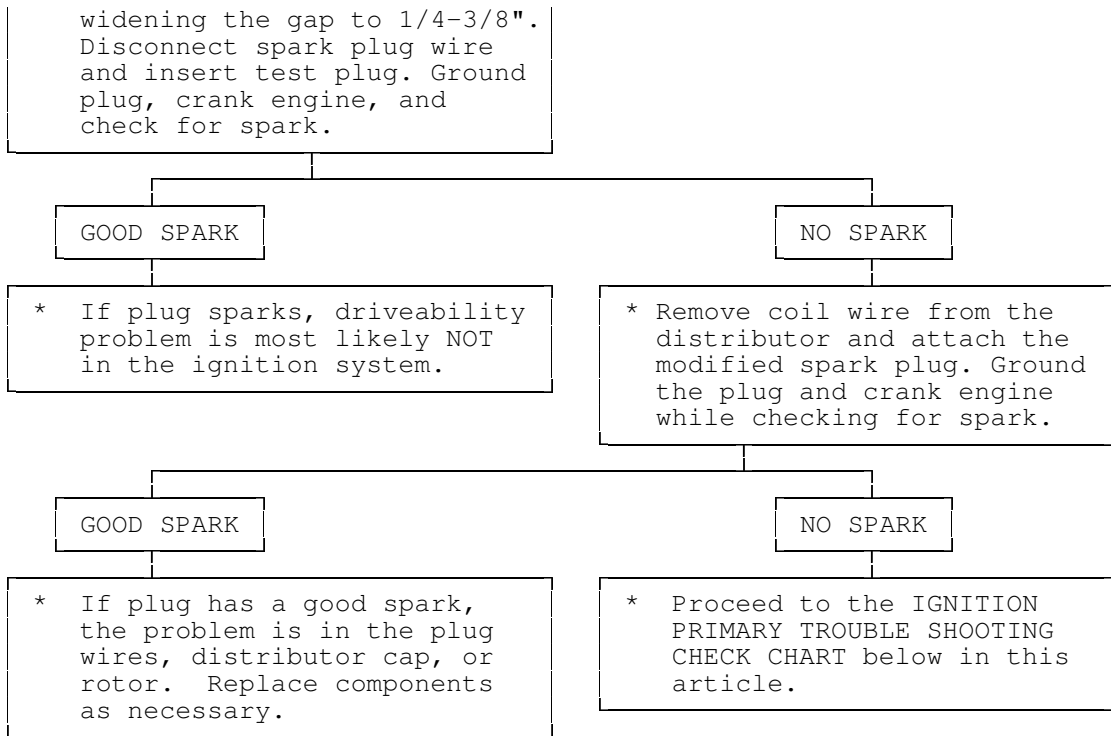

Ignition Primary Trouble Shooting Chart

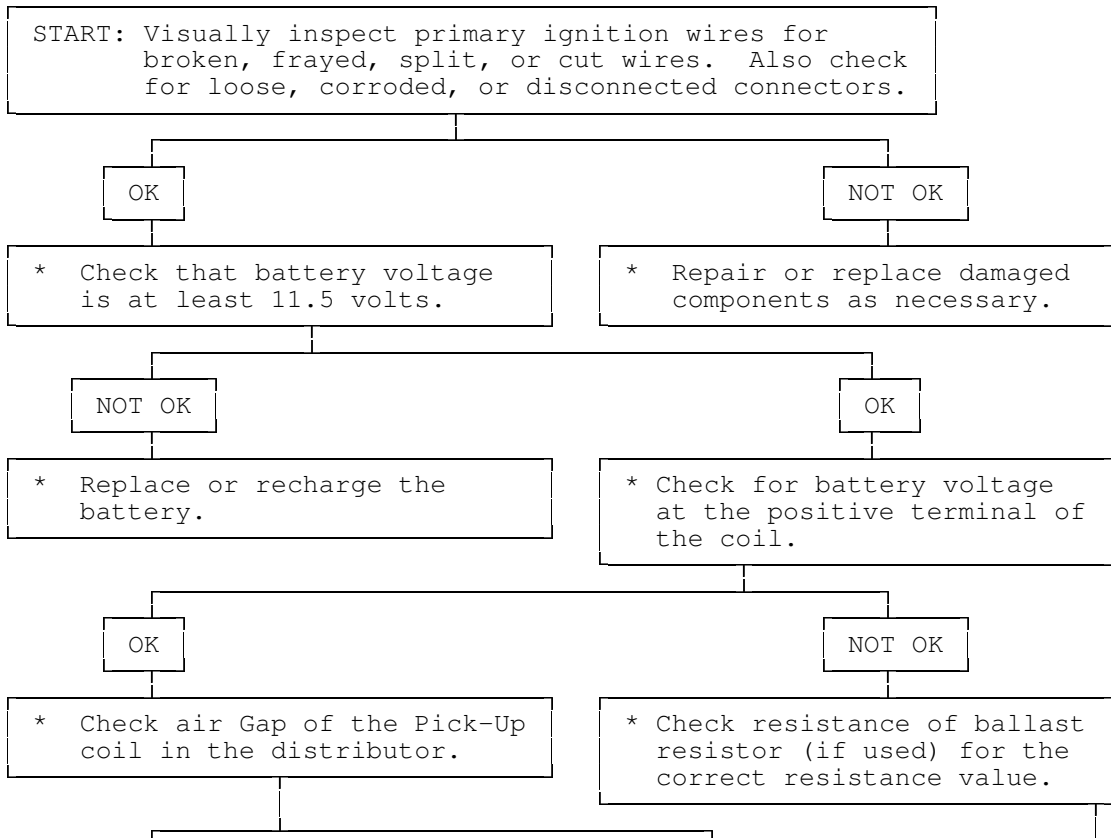

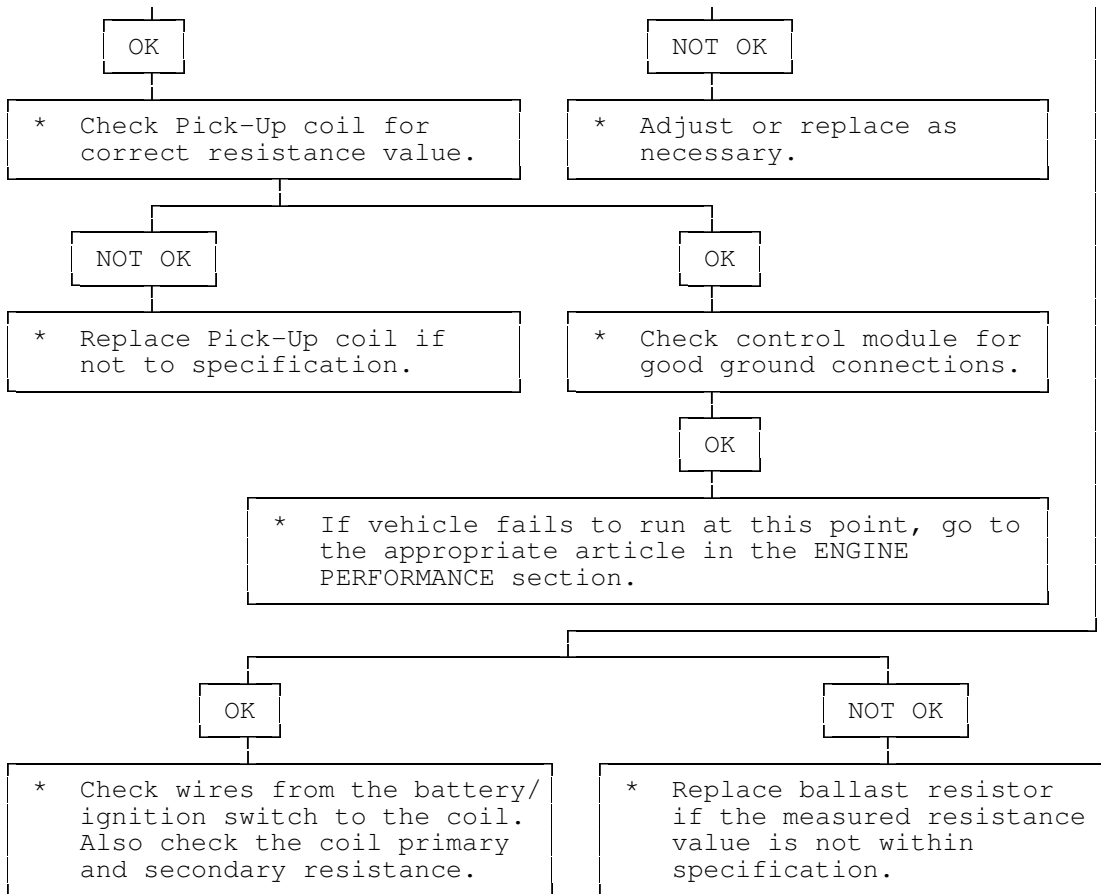

STARTER TROUBLE SHOOTING

NOTE: This is GENERAL information. This article is not intended to be specific to any unique situation or individual vehicle configuration. The purpose of this Trouble Shooting information is to provide a list of common causes to problem symptoms. For model-specific Trouble Shooting, refer to SUBJECT, DIAGNOSTIC, or TESTING articles available in the section(s) you are accessing.

BASIC STARTER TROUBLE SHOOTING CHART

CONDITION	POSSIBLE CAUSE	CORRECTION
Starter Fails to Operate	Dead battery or bad connections between starter and battery	Check battery charge and all wires and connections to starter
	Ignition switch faulty or misadjusted	Adjust or replace ignition switch
	Open circuit between starter switch ignition terminal on starter relay	Check and repair wires and connections as necessary
	Starter relay or starter defective	See Testing in STARTER article

	Open solenoid pull-in wire	See Testing in STARTER article
Starter Does Not Operate and Headlights Dim	Weak battery or dead cell	Charge or replace battery as necessary
	Loose or corroded battery connections	Check that battery connections are clean and tight
	Internal ground in starter windings	See Testing in STARTER article
	Grounded starter fields	See Testing in STARTERS
	Armature rubbing on pole shoes	See STARTER article
Starter Turns but Engine Does Not Rotate	Starter clutch slipping	See STARTER article
	Broken clutch housing	See STARTER article
	Pinion shaft rusted or dry	See STARTER article
	Engine basic timing incorrect	See Ignition Timing in TUNE-UP article
	Broken teeth on engine flywheel	Replace flywheel and check for starter pinion gear damage
Starter Will Not Crank Engine	Faulty overrunning clutch	See STARTER article
	Broken clutch housing	See STARTER article
	Broken flywheel teeth	Replace flywheel and check for starter pinion gear damage
	Armature shaft sheared or reduction gear teeth stripped	See STARTER article
	Weak battery	Charge or replace battery as necessary
	Faulty solenoid	See On-Vehicle Tests in STARTER article
	Poor grounds	Check all ground connections for tight and clean connections
	Ignition switch faulty or misadjusted	Adjust or replace ignition switch as necessary
Starter Cranks Engine Slowly	Battery weak or defective	Charge or replace battery as necessary

Engine overheated	See ENGINE COOLING SYSTEM article
Engine oil too heavy	Check that proper viscosity oil is used
Poor battery-to-starter connections	Check that all between battery and starter are clean and tight
Current draw too low or too high	See Bench Tests in STARTER article
Bent armature, loose pole shoes screws or worn bearings	See STARTER article
Burned solenoid contacts	Replace solenoid
Faulty starter	Replace starter

Starter Engages Engine Only Momentarily	Engine timing too far advanced	See Ignition Timing in TUNE-UP article
	Overrunning clutch not engaging properly	Replace overrunning clutch. See STARTER article
	Broken starter clutch	See STARTER article
	Broken teeth on engine flywheel	Replace flywheel and check starter pinion gear for damage
	Weak drive assembly thrust spring	See STARTER article
	Weak hold-in coil	See Bench Tests in STARTER article

Starter Drive Will Not Engage	Defective point assembly	See Testing in STARTER article
	Poor point assembly ground	See Testing in STARTER article
	Defective pull-in coil	Replace starter solenoid

Starter Relay Does Not Close	Dead battery	Charge or replace battery as necessary
	Faulty wiring	Check all wiring and connections leading to relay
	Neutral safety switch faulty	Replace neutral safety switch
	Starter relay faulty	Replace starter relay

Starter Drive Will Not Disengage	Starter motor loose on mountings	Tighten starter attach bolts
	Worn drive end bushing	See STARTER article
	Damaged engine flywheel teeth	Replace flywheel and starter pinion gear for damage
	Drive yolk return spring broken or missing	Replace return spring
	Faulty ignition switch	Replace ignition switch
	Insufficient clearance between winding leads to solenoid terminal and main contact in solenoid	Replace starter solenoid
	Starter clutch not disengaging	Replace starter clutch
Starter Relay Operates but Solenoid Does Not	Ignition starter switch contacts sticking	Replace ignition switch
	Faulty solenoid switch, switch connections or	Check all wiring between relay and solenoid or replace relay or solenoid as necessary
Solenoid Plunger Vibrates When Switch is Engaged	Broken lead or loose soldered connections	Repair wire or wire connections as necessary
	Weak battery	Charge or replace battery as necessary
	Solenoid contacts corroded	Clean contacts or replace solenoid
	Faulty wiring	Check all wiring leading to solenoid
	Broken connections inside switch cover	Repair connections or replace solenoid
Low Current Draw	Open hold-in wire	Replace solenoid
	Worn brushes or weak	Replace brushes or brush springs as necessary
High Pitched Whine During Cranking Before Engine Fires but Engine Fires and Cranks Normally	Distance too great between starter pinion and flywheel	Align starter or check that correct starter and flywheel are being used
	Distance too small between starter pinion and flywheel	

Fires With Key released. Engine Fires and Cranks Normally Flywheel runout contributes to the intermittent nature

AIR CONDITIONING & HEAT

AIR CONDITIONING TROUBLE SHOOTING

WARNING: This is GENERAL information. This article is not intended to be specific to any unique situation or individual vehicle configuration. The purpose of this Trouble Shooting information is to provide a list of common causes to problem symptoms. For model-specific Trouble Shooting, refer to SUBJECT, DIAGNOSTIC, or TESTING articles available in the section(s) you are accessing.

BASIC AIR CONDITIONING TROUBLE SHOOTING CHART

CONDITION	POSSIBLE CAUSE
Compressor Not Working	<ul style="list-style-type: none">• Compressor clutch circuit open.• Compressor clutch coil inoperative.• Poor clutch ground connection.• Fan belts loose.• Thermostatic switch inoperative.• Thermostatic switch not adjusted.• Ambient temperature switch open.• Superheat fuse blown.
Excessive Noise or Vibration	<ul style="list-style-type: none">• Missing or loose mounting bolts.• Bad idler pulley bearings.• Fan belts not tightened correctly.• Compressor clutch contacting body.• Excessive system pressure.• Compressor oil level low.• Damaged clutch bearings.• Damaged reed valves.• Damaged compressor.
Insufficient or No Cooling; Compressor Working	<ul style="list-style-type: none">• Expansion valve inoperative.• Heater control valve stuck open.• Low system pressure.• Blocked condenser fins.• Blocked evaporator fins.• Vacuum system leak.• Vacuum motors inoperative.• Control cables improperly adjusted.• Restricted air inlet.• Mode doors binding.• Blower motor inoperative.• Temperature above system capacity.

HEATER SYSTEM TROUBLE SHOOTING

NOTE: This is GENERAL information. This article is not intended to be specific to any unique situation or individual vehicle configuration. The purpose of this Trouble Shooting information is to provide a list of common causes to

problem symptoms. For model-specific Trouble Shooting, refer to DIAGNOSTIC, or TESTING articles available in the section(s) you are accessing.

BASIC HEATER SYSTEM TROUBLE SHOOTING CHART

CONDITION	POSSIBLE CAUSE
Insufficient, Erratic, or No Heat	<ul style="list-style-type: none"> • Low Coolant Level • Incorrect thermostat. • Restricted coolant flow through heater core. • Heater hoses plugged. • Misadjusted control cable. • Sticking heater control valve. • Vacuum hose leaking. • Vacuum hose blocked. • Vacuum motors inoperative. • Blocked air inlet. • Inoperative heater blower motor. • Oil residue on heater core fins. • Dirt on heater core fins.
Too Much Heat	<ul style="list-style-type: none"> • Improperly adjusted cables. • Sticking heater control valve. • No vacuum to heater control valve. • Temperature door stuck open.
Air Flow Changes During Acceleration	<ul style="list-style-type: none"> • Vacuum system leak. • Bad check valve or reservoir.
Air From Defroster At All Times	<ul style="list-style-type: none"> • Vacuum system leak. • Improperly adjusted control cables. • Inoperative vacuum motor.
Blower Does Not Operate Correctly	<ul style="list-style-type: none"> • Blown fuse. • Blower motor windings open. • Resistors burned out. • Motor ground connection loose. • Wiring harness connections loose. • Blower motor switch inoperative. • Blower relay inoperative. • Fan binding or foreign object in housing. • Fan blades broken or bent.

BRAKES

BRAKE SYSTEM TROUBLE SHOOTING

NOTE: This is GENERAL information. This article is not intended to be specific to any unique situation or individual vehicle configuration. The purpose of this Trouble Shooting information is to provide a list of common causes to problem symptoms. For model-specific Trouble Shooting, refer to SUBJECT, DIAGNOSTIC, or TESTING articles available in the section(s) you are accessing.

BRAKE SYSTEM TROUBLE SHOOTING CHART

CONDITION	POSSIBLE CAUSE	CORRECTION
Brakes Pull Left or Right	Incorrect tire pressure	Inflate tires to proper pressure
	Front end out of alignment	See WHEEL ALIGNMENT
	Mismatched tires	Check tires sizes
	Restricted brake lines or hoses	Check hose routing
	Loose or malfunctioning caliper	See DISC BRAKES or BRAKE SYSTEM
	Bent shoe or oily linings	See DRUM BRAKES or BRAKE SYSTEM
	Malfunctioning rear brakes	See DRUM, DISC BRAKES or BRAKE SYSTEM
Loose suspension parts	See SUSPENSION	
Noises Without Brakes Applied	Front linings worn out	Replace linings
	Dust or oil on drums or rotors	See DRUM, DISC BRAKES or BRAKE SYSTEM
Noises With Brakes Applied	Insulator on outboard shoe damaged	See DISC BRAKES or BRAKE SYSTEM
	Incorrect pads or linings	Replace pads or linings
Brake Rough, Chatters or Pulsates	Excessive lateral runout	Check rotor runout
	Parallelism not to specifications	Reface or replace rotor
	Wheel bearings not adjusted	See SUSPENSION
	Rear drums out-of-round	Reface or replace drums
	Disc pad reversed, steel against rotor	Remove and reinstall pad
Excessive Pedal Effort	Malfunctioning power unit	See POWER BRAKES or BRAKE SYSTEM
	Partial system failure	Check fluid and pipes
	Worn disc pad or lining	Replace pad or lining
	Caliper piston stuck or	

sluggish	See DISC BRAKES or BRAKE SYSTEM
Master cylinder piston stuck	See MASTER CYLINDERS or BRAKE SYSTEM
Brake fade due to incorrect pads for linings	Replace pads or linings
Linings or pads glazed	Replace pads or linings
Worn drums	Reface or replace drums

Excessive Pedal Travel

Partial brake system failure	Check fluid and pipes
Insufficient fluid in master cylinder	See MASTER CYLINDERS or BRAKE SYSTEM
Air trapped in system	See BRAKE BLEEDING or BRAKE SYSTEM
Rear brakes not adjusted	See Adjustments in DRUM BRAKES or BRAKE SYSTEM
Bent shoe or lining	See DRUM BRAKES or BRAKE SYSTEM
Plugged master cylinder cap	See MASTER CYLINDERS or BRAKE SYSTEM
Improper brake fluid	Replace brake fluid

Pedal Travel Decreasing

Compensating port plugged	See MASTER CYLINDERS or BRAKE SYSTEM
Swollen cup in master cylinder	See MASTER CYLINDERS or BRAKE SYSTEM
Master cylinder piston not returning	See MASTER CYLINDERS or BRAKE SYSTEM
Weak shoe retracting springs	See DRUM BRAKES BRAKE SYSTEM
Wheel cylinder piston sticking	See DRUM BRAKES or BRAKE SYSTEM

Dragging Brakes

Master cylinder pistons not returning	See MASTER CYLINDERS BRAKE SYSTEM
Restricted brake lines or hoses	Check line routing
Incorrect parking brake adjustment	See DRUM BRAKES BRAKE SYSTEM

Parking Brake cables frozen	See DRUM BRAKES BRAKE SYSTEM
Incorrect installation of inboard disc pad	Remove and replace correctly
Power booster output rod too long	See POWER BRAKE UNITS BRAKE SYSTEM
Brake pedal not returning freely	See DISC, DRUM BRAKES BRAKE SYSTEM

Brakes Grab or Uneven Braking
Action

Malfunction of combination valve	See CONTROL VALVE or BRAKE SYSTEM
Malfunction of power brake unit	See POWER BRAKE UNITS or BRAKE SYSTEM
Binding brake pedal	See DISC, DRUM BRAKES or BRAKE SYSTEM

Pulsation or Roughness

Uneven pad wear caused by caliper	See DISC BRAKES or BRAKE SYSTEM
Uneven rotor wear	See DISC BRAKES or BRAKE SYSTEM
Drums out-of-round	Reface or replace drums

ENGINE MECHANICAL

COOLING SYSTEM TROUBLE SHOOTING

NOTE: This is GENERAL information. This article is not intended to be specific to any unique situation or individual vehicle configuration. The purpose of this Trouble Shooting information is to provide a list of common causes to problem symptoms. For model-specific Trouble Shooting, refer to SUBJECT, DIAGNOSTIC, or TESTING articles available in the section(s) you are accessing.

COOLING SYSTEM TROUBLE SHOOTING

CONDITION	POSSIBLE CAUSE	CORRECTION
Overheating	Coolant Leak	Fill/Pressure Test System
	A/C Condenser Fins Clogged	Remove/Clean Condenser
	Radiator Fins Clogged	Remove/Clean Radiator
	Thermostat Stuck Closed	Replace Thermostat
	Clogged Cooling System Passages	Clean/Flush Cooling System

	Water Pump Malfunction	Replace Water Pump
	Fan Clutch Malfunction	Replace Fan Clutch
	Retarded Ignition Timing	Reset Ignition Timing
	Cooling Fan Malfunction	Test Cooling Fan/ Circuit
	Cooling Fan Motor Malfunction	Test Fan Motor
	Cooling Fan Relay Malfunction	Test Fan Relay
	Faulty Radiator Cap	Replace Radiator Cap
	Broken/Slipping Fan Belt	Replace Fan Belt
	Restricted Exhaust	Repair Exhaust System
Corrosion	Impurities In Coolant	Clean/Flush System
Coolant Leakage	Damaged hose	Replace Hose
	Leaky Water Pump	Replace Water Pump
	Damaged Radiator Seam	Replace/Repair Radiator
	Leaky Thermostat Cover	Replace Thermostat Cover
	Cylinder Head Problem	Check Head/Head Gasket
	Leaky Freeze Plugs	Replace Freeze Plugs
Recovery System Inoperative	Loose and/or Defective Radiator Cap	Replace Radiator Cap
	Overflow Tube Clogged and/or Leaking	Repair Tube
	Recovery Bottle Vent Restricted	Clean Vent
No Heater Core Flow	Collapsed Heater Hose	Replace Heater Hose
	Plugged Heater Core	Clean/Replace Heater Core
	Faulty Heater Valve	Replace Heater Valve

GASOLINE ENGINE - MECHANICAL TROUBLE SHOOTING

NOTE: This is GENERAL information. This article is not intended to be specific to any unique situation or individual vehicle configuration. The purpose of this Trouble Shooting information is to provide a list of common causes to problem symptoms. For model-specific Trouble Shooting, refer to SUBJECT, DIAGNOSTIC, or TESTING articles available

in the section(s) you are accessing.

BASIC GASOLINE ENGINE - MECHANICAL TROUBLE SHOOTING CHART

CONDITION	POSSIBLE CAUSE	CORRECTION
Engine Lopes At Idle	Intake manifold-to-head leaks	Replace manifold gasket, See ENGINES
	Blown head gasket	Replace head gasket, See ENGINES
	Worn timing gears, chain or sprocket	Replace gears, chain or sprocket
	Worn camshaft lobes	Replace camshaft, See ENGINES
	Overheated engine	Check cooling system, See COOLING
	Blocked crankcase vent valve	Remove restriction
	Leaking EGR valve	Repair leak and/or replace valve
Engine Has Low Power	Faulty fuel pump	Replace fuel pump
	Leaking fuel pump	Repair leak and/or replace fuel pump
	Excessive piston-to-bore clearance	Install larger pistons, See ENGINES
	Sticking valves or weak valve springs	Check valve train components, See ENGINES
	Incorrect valve timing	Reset valve timing, See ENGINES
	Worn camshaft lobes	Replace camshaft, See ENGINES
	Blown head gasket	Replace head gasket. See ENGINES.
	Clutch slipping	Adjust pedal and/or replace components, See ENGINES
	Engine overheating	Check cooling system, See COOLING
	Auto. Trans. pressure regulator valve faulty	Replace pressure regulator valve
	Auto. Trans. fluid level too low	Add fluid as necessary
	Improper vacuum diverter valve operation	Replace vacuum diverter valve
	Vacuum leaks	Inspect vacuum system and repair as required
Leaking piston rings	Replace piston rings, See ENGINES	
Faulty High Speed Operation	Low fuel pump volume	Replace fuel pump
	Leaking valves or worn	Replace valves and/or springs, See ENGINES
	Incorrect valve timing	Reset valve timing, See ENGINES
	Intake manifold restricted	Remove restriction
Faulty Acceleration	Worn distributor shaft	Replace distributor
	Improper fuel pump stroke	Remove pump and reset pump stroke

	Incorrect ignition timing	Reset ignition timing, See TUNE-UP
	Leaking valves	Replace valves, See ENGINES
	Worn fuel pump diaphragm or piston	Replace diaphragm or piston
Intake Backfire	Improper ignition timing	Reset ignition timing, See TUNE-UP
	Faulty accelerator pump discharge	Replace accelerator pump
	Improper choke operation	Check choke and adjust as required
	Defective EGR valve	Replace EGR valve
	Fuel mixture too lean	Reset air/fuel mixture, See TUNE-UP
	Choke valve initial clearance too large	Reset choke valve initial clearance
Exhaust Backfire	Vacuum leak	Inspect and repair vacuum system
	Faulty vacuum diverter valve	Replace vacuum diverter valve
	Faulty choke operation	Check choke and adjust as required
	Exhaust system leak	repair exhaust system leak
Engine Detonation	Ignition timing too far advanced	Reset ignition timing, See TUNE-UP
	Faulty ignition system	Check ignition timing, See TUNE-UP
	Spark plugs loose or faulty	Retighten or replace plugs
	Fuel delivery system clogged	Inspect lines, pump and filter for clog
	EGR valve inoperative	Replace EGR valve
	PCV system inoperative	Inspect and/or replace hoses or valve
	Vacuum leaks	Check vacuum system and repair leaks
	Excessive combustion chamber deposits	Remove built-up deposits
Leaking, sticking or broken valves	Inspect and/or replace valves	
External Oil Leakage	Fuel pump improperly seated or worn gasket	Remove pump, replace gasket and seat properly
	Oil pan gasket broken or pan bent	Straighten pan and replace gasket
	Timing chain cover gasket broken	Replace timing chain cover gasket
	Rear main oil seal worn	Replace rear main oil seal
	Oil pan drain plug not seated properly	Remove and reinstall drain plug
	Camshaft bearing drain hole blocked	Remove restriction
	Oil pressure sending switch leaking	Remove and reinstall sending switch

Excessive Oil Consumption	Worn valve stems or guides	Replace stems or guides, See ENGINES
	Valve "O" ring seals damaged	Replace "O" ring seals, See ENGINES
	Plugged oil drain back holes	Remove restrictions
	Improper PCV valve operation	Replace PCV valve
	Engine oil level too high	Remove excess oil
	Engine oil too thin	Replace thicker oil
	Valve stem oil deflectors damaged	Replace oil deflectors
	Incorrect piston rings	Replace piston rings, See ENGINES
	Piston ring gaps not staggered	Reinstall piston rings, See ENGINES
	Insufficient piston ring tension	Replace rings, See ENGINES
	Piston ring grooves or oil return slots clogged	Replace piston rings, See ENGINES
	Piston rings sticking in grooves	Replace piston rings, See ENGINES
	Piston ring grooves excessively worn	Replace piston and rings, See ENGINES
	Compression rings installed upside down	Replace compression rings correctly, See ENGINES
	Worn or scored cylinder walls	Rebore cylinders or replace block
	Mismatched oil ring expander and rail	Replace oil ring expander and rail, See ENGINES
	Intake gasket dowels too long	Replace intake gasket dowels
	Excessive main or connecting rod bearing clearance	Replace main or connecting rod bearings, See ENGINES
	<hr/>	
No Oil Pressure	Low oil level	Add oil to proper level
	Oil pressure sender or gauge broken	Replace sender or gauge
	Oil pump malfunction	Remove and overhaul oil pump, See ENGINES
	Oil pressure relief valve sticking	Remove and reinstall valve
	Oil pump passages blocked	Overhaul oil pump, See ENGINES
	Oil pickup screen or tube blocked	remove restriction
	Loose oil inlet tube	Tighten oil inlet tube
	Loose camshaft bearings	Replace camshaft bearings, See ENGINES
Internal leakage at oil passages	Replace block or cylinder head	
<hr/>		
Low Oil Pressure	Low engine oil level	Add oil to proper level
	Engine oil too thin	Remove and replace with thicker oil
	Excessive oil pump clearance	Reduce oil pump clearance, See ENGINES
	Oil pickup tube or screen blocked	Remove restrictions
	Main, rod or cam bearing clearance excessive	Replace bearing to reduce clearance, See

ENGINES

High Oil Pressure	Improper grade of oil Oil pressure relief valve stuck closed Oil pressure sender or gauge faulty	Replace with proper oil Eliminate binding Replace sender or gauge
Noisy Main Bearings	Inadequate oil supply Excessive main bearing clearance Excessive crankshaft end play Loose flywheel or torque converter Loose or damaged vibration damper Crankshaft journals out-of-round Excessive belt tension	Check oil delivery to main bearings Replace main bearings, See ENGINES Replace crankshaft, See ENGINES Tighten attaching bolts Tighten or replace vibration damper Re-grind crankshaft journals Loosen belt tension
Noisy Connecting Rods	Excessive bearing clearance or missing bearing Crankshaft rod journal out-of-round Misaligned connecting rod or cap Incorrectly tightened rod bolts	Replace bearing, See ENGINES Re-grind crankshaft journal Remove rod or cap and realign Remove and re-tighten rod bolts
Noisy Pistons and Rings	Excessive piston-to-bore clearance Bore tapered or out-of-round Piston ring broken Piston pin loose or seized Connecting rods misaligned Ring side clearance too loose or tight Carbon build-up on piston	Install larger pistons, See ENGINES Rebore block Replace piston rings, See ENGINES Replace piston pin, See ENGINES Realign connecting rods Replace with larger or smaller rings Remove carbon
Noisy Valve Train	Worn or bent push rods Worn rocker arms or bridged pivots Dirt or chips in valve lifters Excessive valve lifter leak-down Valve lifter face worn Broken or cocked valve springs Too much valve stem-to-guide clearance Valve bent Loose rocker arms Excessive valve seat run-out	Replace push rods, See ENGINES Replace push rods, See ENGINES Remove lifters and remove dirt/chips Replace valve lifters, See ENGINES Replace valve lifters, See ENGINES replace or reposition springs Replace valve guides, See ENGINES Replace valve, See ENGINES Retighten rocker arms, See ENGINES Reface valve seats, See ENGINES

	Missing valve lock	Install new valve lock
	Excessively worn camshaft lobes	Replace camshaft, See ENGINES
	Plugged valve lifter oil holes	Eliminate restriction or replace lifter
	Faulty valve lifter check ball	Replace lifter check ball, See ENGINES
	Rocker arm nut installed upside down	Remove and reinstall correctly
	Valve lifter incorrect for engine	Remove and replace valve lifters
	Faulty push rod seat or lifter plunger	Replace plunger or push rod
Noisy Valves	Improper valve lash	Re-adjust valve lash, See ENGINES
	Worn or dirty valve lifters	Clean and/or replace lifters
	Worn valve guides	Replace valve guides, See ENGINES
	Excessive valve seat or face run-out	Reface seats or valve face
	Worn camshaft lobes	Replace camshaft, See ENGINES
	Loose rocker arm studs	Re-tighten rocker arm studs, See ENGINES
	Bent push rods	Replace push rods, See ENGINES
	Broken valve springs	Replace valve springs, See ENGINES
Burned, Sticking or Broken Valves	Weak valve springs or warped valves	Replace valves and/or springs, See ENGINES
	Improper lifter clearance	Re-adjust clearance or replace lifters
	Worn guides or improper guide clearance	Replace valve guides, See ENGINES
	Out-of-round valve seats or improper seat width	Re-grind valve seats
	Gum deposits on valve stems, seats or guides	Remove deposits
	Improper spark timing	Re-adjust spark timing
Broken Pistons/Rings	Undersize pistons	Replace with larger pistons, See ENGINES
	Wrong piston rings	Replace with correct rings, See ENGINES
	Out-of-round cylinder bore	Re-bore cylinder bore
	Improper connecting rod alignment	Remove and realign connecting rods
	Excessively worn ring grooves	Replace pistons, See ENGINES
	Improperly assembled piston pins	Re-assemble pin-to-piston, See ENGINES
	Insufficient ring gap clearance	Install new rings, See ENGINES
	Engine overheating	Check cooling system
	Incorrect ignition timing	Re-adjust ignition timing, See TUNE-UP
Excessive Exhaust Noise	Leaks at manifold to head, or to pipe	Replace manifold or pipe gasket
	Exhaust manifold	Replace exhaust

cracked or broken

manifold, See ENGINES

ENGINE PERFORMANCE

CARBURETOR TROUBLE SHOOTING:

NOTE: This is GENERAL information. This article is not intended to be specific to any unique situation or individual vehicle configuration. The purpose of this Trouble Shooting information is to provide a list of common causes to problem symptoms. For model-specific Trouble Shooting, refer to SUBJECT, DIAGNOSTIC, or TESTING articles available in the section(s) you are accessing.

BASIC COLD START SYMPTOMS TROUBLE SHOOTING CHART

CONDITION	POSSIBLE CAUSE	CORRECTION
Engine Won't Start	Choke not closing	Check choke operation, see FUEL SYSTEMS
	Choke linkage bent	Check linkage, see FUEL SYSTEM
Engine Starts, Then Dies	Choke vacuum kick setting too wide	Check setting and adjust see, FUEL SYSTEMS
	Fast idle RPM too low	Reset RPM to specification, see TUNE-UP
	Fast idle cam index incorrect	Reset fast idle cam index, see FUEL SYSTEMS
	Vacuum leak	Inspect vacuum system for leaks
	Low fuel pump outlet	Repair or replace pump, see FUEL SYSTEMS
	Low carburetor fuel level	Check float setting see FUEL SYSTEM
Engine Quits Under Load	Choke vacuum kick setting incorrect	Reset vacuum kick setting, see FUEL SYSTEMS
	Fast idle cam index incorrect	Reset fast idle cam index, see FUEL SYSTEM
	Incorrect hot fast idle speed RPM	Reset fast idle RPM, see TUNE-UP
Engine Starts, Runs Up, Then Idles, Slowly With Black Smoke	Choke vacuum kick set too narrow	Reset vacuum kick, see FUEL SYSTEMS
	Fast idle cam index	Reset fast idle cam

incorrect	index, see FUEL SYSTEMS
Hot fast idle RPM too low	Reset fast idle RPM, see TUNE-UP

BASIC HOT START SYMPTOMS TROUBLE SHOOTING CHART

CONDITION	POSSIBLE CAUSE	CORRECTION
Engine Won't Start	Engine flooded	Allow fuel to evaporate

BASIC COLD ENGINE DRIVEABILITY SYMPTOMS TROUBLE SHOOTING CHART

CONDITION	POSSIBLE CAUSE	CORRECTION
Engine Stalls in Gear	Choke vacuum kick setting incorrect	Reset choke vacuum kick, see FUEL SYSTEMS
	Fast idle RPM incorrect	Reset fast idle RPM, see TUNE-UP
	Fast idle cam index incorrect	Reset fast idle cam see FUEL SYSTEMS

Acceleration Sag or Stall	Defective choke control switch	Replace choke control switch
	Choke vacuum kick setting incorrect	Reset choke vacuum kick see, FUEL SYSTEMS
	Float level incorrect (too low)	Adjust float level, FUEL SYSTEMS
	Accelerator pump defective	Repair or replace pump see FUEL SYSTEMS
	Secondary throttles not closed	Inspect lockout adjustment, see FUEL SYSTEMS

Sag or Stall After Warmup	Defective choke control switch	Replace choke control switch, see FUEL SYSTEMS
	Defective accelerator pump	Replace pump, see FUEL SYSTEMS
	Float level incorrect (too low)	Adjust float level, see FUEL SYSTEMS

Backfiring & Black Smoke	Plugged heat crossover system	Remove restriction
--------------------------	-------------------------------	--------------------

BASIC WARM ENGINE DRIVEABILITY SYMPTOMS TROUBLE SHOOTING CHART

CONDITION	POSSIBLE CAUSE	CORRECTION
Hesitation With Small Amount of Gas Pedal Movement	Vacuum leak	Inspect vacuum lines
	Accelerator pump weak or inoperable	Replace pump, see FUEL SYSTEMS
	Float level setting too low	Reset float level, see, FUEL SYSTEMS
	Metering rods sticking or binding	Inspect and/or replace rods, see FUEL SYSTEMS
	Carburetor idle or transfer system plugged	Inspect system and remove restriction
	Frozen or binding heated air inlet	Inspect heated air door for binding
Hesitation With Heavy Gas Pedal Movement	Defective accelerator pump	Replace pump, see FUEL SYSTEMS
	Metering rod carrier sticking or binding	Remove restriction
	Large vacuum leak	Inspect vacuum system and repair leak
	Float level setting too low	Reset float level, see FUEL SYSTEMS
	Defective fuel pump, lines or filter	Inspect pump, lines and filter
	Air door setting incorrect	Adjust air door setting, see FUEL

DIESEL ENGINE TROUBLE SHOOTING

NOTE: This is GENERAL information. This article is not intended to be specific to any unique situation or individual vehicle configuration. The purpose of this Trouble Shooting information is to provide a list of common causes to problem symptoms. For model-specific Trouble Shooting, refer to SUBJECT, DIAGNOSTIC, or TESTING articles available in the section(s) you are accessing.

NOTE: Diesel engines mechanical diagnosis is the same as gasoline engines for items such as noisy valves, bearings, pistons, etc. The following trouble shooting covers only items pertaining to diesel engines.

BASIC DIESEL ENGINE TROUBLE SHOOTING CHART

CONDITION	POSSIBLE CAUSE	CORRECTION
Engine Won't Crank	Bad battery connections or dead batteries	Check connections and/or replace

	Bad starter connections or bad starter	batteries Check connections and/or replace batteries
Engine Cranks Slowly, Won't Start	Bad battery connections or dead batteries Engine oil too heavy	Check connections and/or replace batteries Replace engine oil
Engine Cranks Normally, But Will Not Start	Glow plugs not functioning Glow plug control not functioning Fuel not injected into cylinders No fuel to injection pump Fuel filter blocked Fuel tank filter blocked Fuel pump not operating Fuel return system blocked No voltage to fuel solenoid Incorrect or contaminated fuel Incorrect injection pump timing Low compression Injection pump malfunction	Check glow plug system, see FUEL SYSTEMS Check controller, see FUEL SYSTEMS Check fuel injectors, see FUEL SYSTEMS Check fuel delivery system Replace fuel filter Replace fuel tank filter Check pump operation and/or replace pump Inspect system and remove restriction Check solenoid and connections Replace fuel Re-adjust pump timing, see FUEL SYSTEMS Check valves, pistons, rings, see ENGINES Inspect and/or replace injection pump
Engine Starts, Won't Idle	Incorrect slow idle adjustment Fast idle solenoid malfunctioning Fuel return system blocked Glow plugs go off too soon Injection pump timing incorrect No fuel to injection pump Incorrect or contaminated fuel Low compression Injection pump malfunction Fuel solenoid closes in RUN position	Reset idle adjustment, see TUNE-UP Check solenoid and connections Check system and remove restrictions See glow plug diagnosis in FUEL SYSTEMS Reset pump timing, see FUEL SYSTEMS Check fuel delivery system Replace fuel Check valves, piston, rings, see ENGINES Replace injection pump, see FUEL SYSTEMS Check solenoid and connections
Engines Starts/ Idles Rough W/out Smoke or Noise	Incorrect slow idle adjustment Injection line fuel leaks Fuel return system blocked	Reset slow idle, see TUNE-UP Check lines and connections Check lines and connections

	Air in fuel system Incorrect or contaminated fuel Injector nozzle malfunction	Bleed air from system Replace fuel Check nozzles, see FUEL SYSTEMS
Engines Starts and Idles Rough W/out Smoke or Noise, But Clears After Warm-Up	Injection pump timing incorrect Engine not fully broken in Air in system Injector nozzle malfunction	Reset pump timing, see FUEL SYSTEMS Put more miles on engine Bleed air from system Check nozzles, see FUEL SYSTEMS
Engine Idles Correctly, Misfires Above Idle	Blocked fuel filter Injection pump timing incorrect Incorrect or contaminated fuel	Replace fuel filter Reset pump timing, see FUEL SYSTEMS Replace fuel
Engine Won't Return To Idle	Fast idle adjustment incorrect Internal injection pump malfunction External linkage binding	Reset fast idle, see TUNE-UP Replace injection pump, see FUEL SYSTEMS Check linkage and remove binding
Fuel Leaks On Ground	Loose or broken fuel line Internal injection pump seal leak	Check lines and connections Replace injection pump, see FUEL SYSTEMS
Cylinder Knocking Noise	Injector nozzles sticking open Very low nozzle opening pressure	Test injectors, see FUEL SYSTEMS Test injectors and/or replace
Loss of Engine Power	Restricted air intake EGR valve malfunction Blocked or damaged exhaust system Blocked fuel tank filter Restricted fuel filter Block vent in gas cap Tank-to-injection pump fuel supply blocked Blocked fuel return system Incorrect or contaminated fuel Blocked injector nozzles Low compression	Remove restriction Replace EGR valve Remove restriction and/or replace components Replace filter Remove restriction and/or replace filter Remove restriction and/or replace cap Check fuel lines and connections Remove restriction Replace fuel Check nozzle for blockage, see FUEL SYSTEMS Check valves, rings, pistons, see ENGINES
Loud Engine Noise With Black Smoke	Basic timing incorrect EGR valve malfunction Internal injection pump malfunction	Reset timing, see FUEL SYSTEMS Replace EGR valve Replace injection pump, see FUEL SYSTEMS

	Incorrect injector pump housing pressure	Check pressure, see FUEL SYSTEMS
Engine Overheating	Cooling system leaks	Check cooling system and repair leaks
	Belt slipping or damaged	Check tension and/or replace belt
	Thermostat stuck closed	Remove and replace thermostat, see ENGINE COOLING
	Head gasket leaking	Replace head gasket
Oil Light on at Idle	Low oil pump pressure	Check oil pump operation, see ENGINES
	Oil cooler or line restricted	Remove restriction and/or replace cooler
Engine Won't Shut Off	Injector pump fuel solenoid does not return fuel valve to OFF position	Remove and check solenoid and replace if needed

VACUUM PUMP DIAGNOSIS

Excessive Noise	Loose pump-to-drive assembly screws	Tighten screws
	Loose tube on pump assembly	Tighten tube
	Valves not functioning properly	Replace valves
Oil Leakage	Loose end plug	Tighten end plug
	Bad seal crimp	Remove and re-crimp seal

FUEL INJECTION TROUBLE SHOOTING

NOTE: This is GENERAL information. This article is not intended to be specific to any unique situation or individual vehicle configuration. The purpose of this Trouble Shooting information is to provide a list of common causes to problem symptoms. For model-specific Trouble Shooting, refer to SUBJECT, DIAGNOSTIC, or TESTING articles available in the section(s) you are accessing.

BASIC FUEL INJECTION TROUBLE SHOOTING CHART

CONDITION	POSSIBLE CAUSE	CORRECTION
Engine Won't Start (Crank Normally)	Cold start valve inoperative	Test valve and circuit
	Poor connection; vacuum or wiring	Check vacuum and electrical connections
	Contaminated fuel	Test fuel for water or alcohol
	Defective fuel pump relay or circuit	Test relay and wiring
	Battery too low	Charge and test battery

Low fuel pressure	Test pressure regulator and fuel pump, check for restricted lines and filters
No distributor reference pulses	Repair ignition system as necessary
Open coolant temperature sensor circuit	Test sensor and wiring
Shorted W.O.T. switch in T.P.S.	Disconnect W.O.T. switch, engine should start
Defective ECM	Replace ECM
Fuel tank residual pressure valve leaks	Test for fuel pressure drop after shut down

Hard Starting	Disconnected hot air tube to air cleaner	Reconnect tube and test control valve
	Defective Idle Air Control (IAC) valve	Test valve operation and circuit
	Shorted, open or misadjusted T.P.S.	Test and adjust or replace T.P.S.
	EGR valve open	Test EGR valve and control circuit
	Poor Oxygen sensor signal	Test for shorted or circuit
	Incorrect mixture from PCV system	Test PCV for flow, check sealing of oil filter cap

Poor High Speed Operation	Low fuel pump volume	Faulty pump or restricted fuel lines or filters
	Poor MAP sensor signal	Test MAP sensor, vacuum hose and wiring
	Poor Oxygen sensor signal	Test for shorted or open sensor or circuit
	Open coolant temperature sensor circuit	Test sensor and wiring
	Faulty ignition operation	Check wires for cracks or poor connections, test secondary voltage with oscilloscope
	Contaminated fuel	Test fuel for water

		or alcohol
	Intermittent ECM ground	Test ECM ground connection for resistance
	Restricted air cleaner	Replace air cleaner
	Restricted exhaust system	Test for exhaust manifold back pressure
	Poor MAF sensor signal	Check leakage between sensor and manifold
	Poor VSS signal	If tester for ALCL hook-up is available check that VSS reading matches speedometer
Ping or Knock on Acceleration	Poor Knock sensor signal	Test for shorted or open sensor or circuit
	Poor Baro sensor signal	Test for shorted or open sensor or circuit
	Improper ignition timing	See VEHICLE EMISSION CONTROL LABEL (where applicable)
	Check for engine overheating problems	Low coolant, loose belts or electric cooling fan inoperative

NOTE: For additional electronic fuel injection trouble shooting information, see the appropriate article in the ENGINE PERFORMANCE section (not all vehicles have Computer Engine Control articles). Information is provided there for diagnosing fuel system problems on vehicles with electronic fuel injection.

IGNITION SYSTEM TROUBLE SHOOTING

NOTE: This is GENERAL information. This article is not intended to be specific to any unique situation or individual vehicle configuration. The purpose of this Trouble Shooting information is to provide a list of common causes to problem symptoms. For model-specific Trouble Shooting, refer to SUBJECT, DIAGNOSTIC, or TESTING articles available in the section(s) you are accessing.

Ignition Secondary Trouble Shooting Chart

<p>START: Visually inspect Spark Plug Wires, Coil Wires, Plug Wire Boots, Rotor, and Distributor Cap for signs of damage.</p>

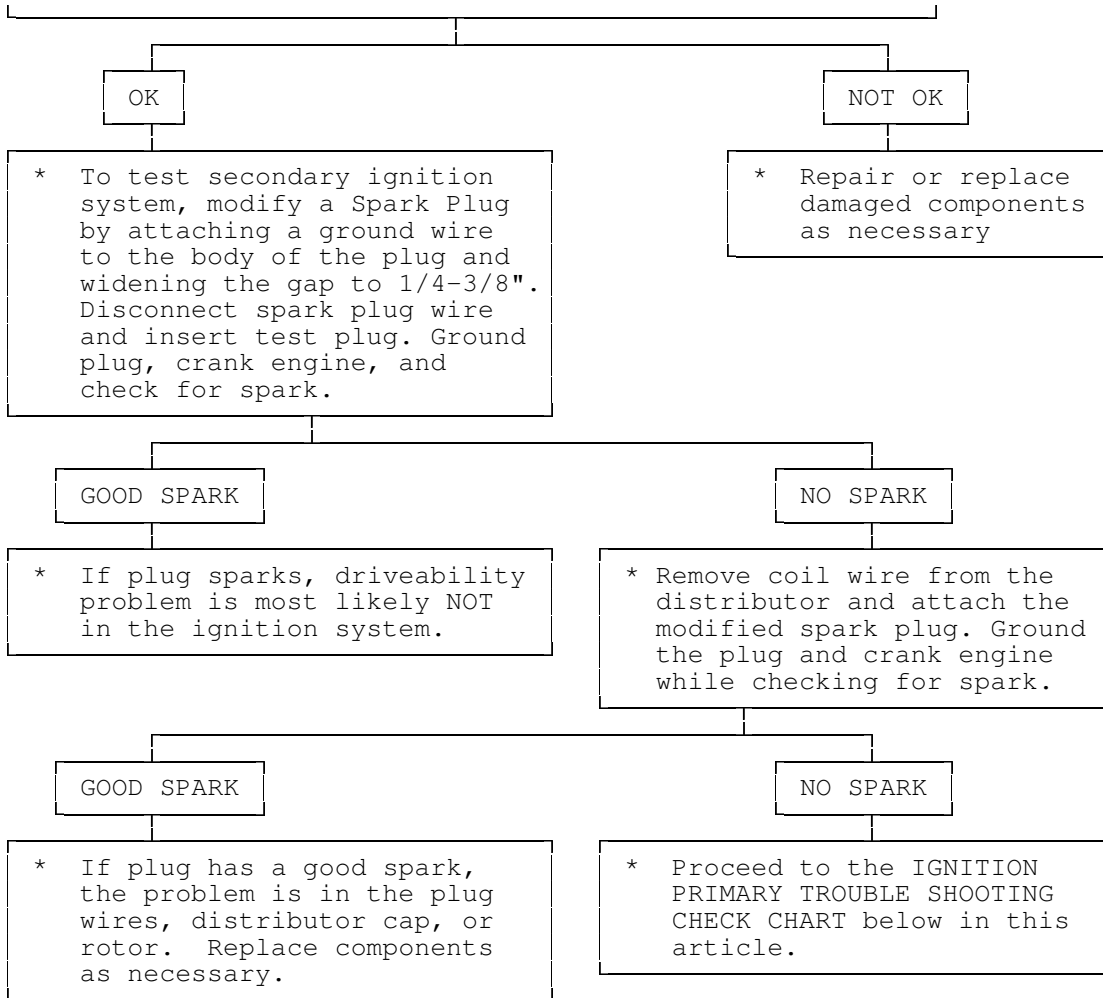

Ignition Primary Trouble Shooting Chart

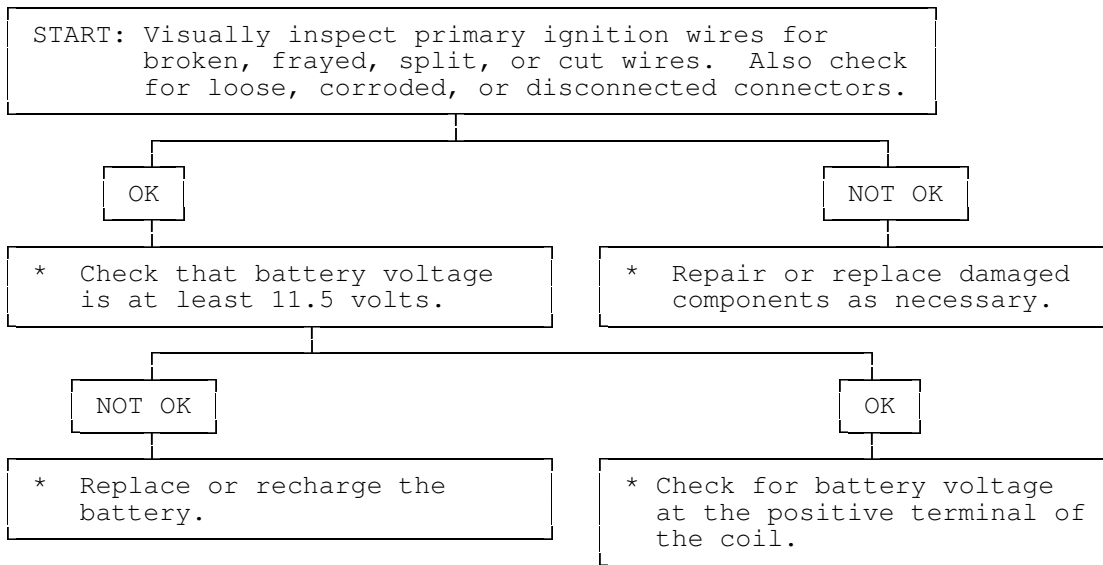

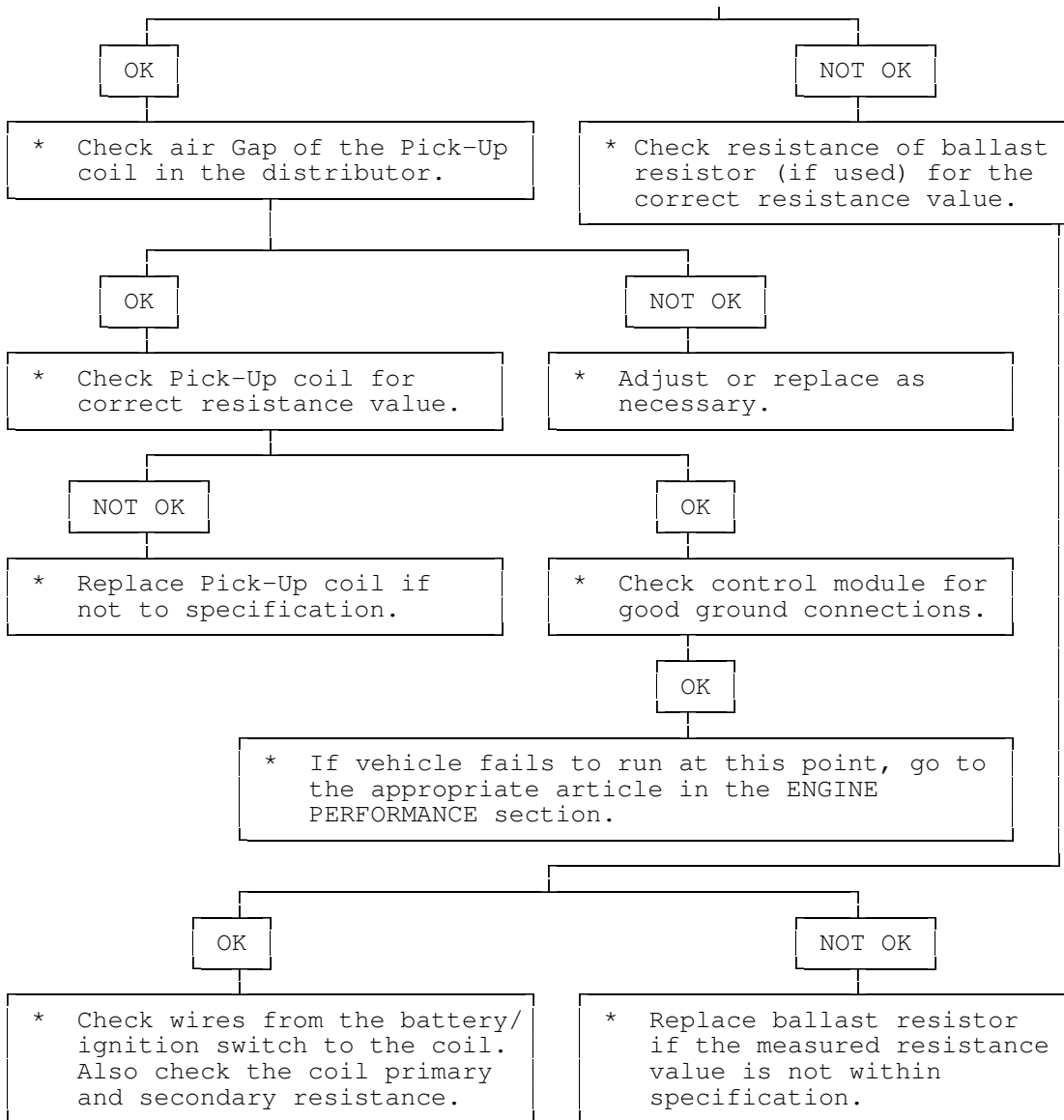

STARTER TROUBLE SHOOTING

NOTE: This is GENERAL information. This article is not intended to be specific to any unique situation or individual vehicle configuration. The purpose of this Trouble Shooting information is to provide a list of common causes to problem symptoms. For model-specific Trouble Shooting, refer to SUBJECT, DIAGNOSTIC, or TESTING articles available in the section(s) you are accessing.

BASIC STARTER TROUBLE SHOOTING CHART

CONDITION	POSSIBLE CAUSE	CORRECTION
Starter Fails to Operate	Dead battery or bad connections between starter and battery	Check battery charge and all wires and connections to starter

	Ignition switch faulty or misadjusted	Adjust or replace ignition switch
	Open circuit between starter switch ignition terminal on starter relay	Check and repair wires and connections as necessary
	Starter relay or starter defective	See Testing in STARTER article
	Open solenoid pull-in wire	See Testing in STARTER article
Starter Does Not Operate and Headlights Dim	Weak battery or dead cell	Charge or replace battery as necessary
	Loose or corroded battery connections	Check that battery connections are clean and tight
	Internal ground in starter windings	See Testing in STARTER article
	Grounded starter fields	See Testing in STARTERS
	Armature rubbing on pole shoes	See STARTER article
Starter Turns but Engine Does Not Rotate	Starter clutch slipping	See STARTER article
	Broken clutch housing	See STARTER article
	Pinion shaft rusted or dry	See STARTER article
	Engine basic timing incorrect	See Ignition Timing in TUNE-UP article
	Broken teeth on engine flywheel	Replace flywheel and check for starter pinion gear damage
Starter Will Not Crank Engine	Faulty overrunning clutch	See STARTER article
	Broken clutch housing	See STARTER article
	Broken flywheel teeth	Replace flywheel and check for starter pinion gear damage
	Armature shaft sheared or reduction gear teeth stripped	See STARTER article
	Weak battery	Charge or replace battery as necessary
	Faulty solenoid	See On-Vehicle Tests in STARTER article
	Poor grounds	Check all ground

		connections for tight and clean connections
	Ignition switch faulty or misadjusted	Adjust or replace ignition switch as necessary
Starter Cranks Engine Slowly	Battery weak or defective	Charge or replace battery as necessary
	Engine overheated	See ENGINE COOLING SYSTEM article
	Engine oil too heavy	Check that proper viscosity oil is used
	Poor battery-to-starter connections	Check that all between battery and starter are clean and tight
	Current draw too low or too high	See Bench Tests in STARTER article
	Bent armature, loose pole shoes screws or worn bearings	See STARTER article
	Burned solenoid contacts	Replace solenoid
	Faulty starter	Replace starter
Starter Engages Engine Only Momentarily	Engine timing too far advanced	See Ignition Timing in TUNE-UP article
	Overrunning clutch not engaging properly	Replace overrunning clutch. See STARTER article
	Broken starter clutch	See STARTER article
	Broken teeth on engine flywheel	Replace flywheel and check starter pinion gear for damage
	Weak drive assembly thrust spring	See STARTER article
	Weak hold-in coil	See Bench Tests in STARTER article
Starter Drive Will Not Engage	Defective point assembly	See Testing in STARTER article
	Poor point assembly ground	See Testing in STARTER article
	Defective pull-in coil	Replace starter solenoid
Starter Relay	Dead battery	Charge or replace

Does Not Close		battery as necessary
	Faulty wiring	Check all wiring and connections leading to relay
	Neutral safety switch faulty	Replace neutral safety switch
	Starter relay faulty	Replace starter relay
Starter Drive Will Not Disengage	Starter motor loose on mountings	Tighten starter attach bolts
	Worn drive end bushing	See STARTER article
	Damaged engine flywheel teeth	Replace flywheel and starter pinion gear for damage
	Drive yolk return spring broken or missing	Replace return spring
	Faulty ignition switch	Replace ignition switch
	Insufficient clearance between winding leads to solenoid terminal and main contact in solenoid	Replace starter solenoid
	Starter clutch not disengaging	Replace starter clutch
	Ignition starter switch contacts sticking	Replace ignition switch
Starter Relay Operates but Solenoid Does Not	Faulty solenoid switch, switch connections or	Check all wiring between relay and solenoid or replace relay or solenoid as necessary
	Broken lead or loose soldered connections	Repair wire or wire connections as necessary
Solenoid Plunger Vibrates When Switch is Engaged	Weak battery	Charge or replace battery as necessary
	Solenoid contacts corroded	Clean contacts or replace solenoid
	Faulty wiring	Check all wiring leading to solenoid
	Broken connections inside switch cover	Repair connections or replace solenoid
	Open hold-in wire	Replace solenoid
Low Current Draw	Worn brushes or weak	Replace brushes or brush springs as necessary

High Pitched Whine During Cranking Before Engine Fires but Engine Fires and Cranks Normally	Distance too great between starter pinion and flywheel	Align starter or check that correct starter and flywheel are being used
--	--	--

High Pitched Whine After Engine Fires With Key released. Engine Fires and Cranks Normally	Distance too small between starter pinion and flywheel Flywheel runout contributes to the intermittent nature
--	--

TUNE-UP TROUBLE SHOOTING - GAS ENGINE VEHICLES

NOTE: This is GENERAL information. This article is not intended to be specific to any unique situation or individual vehicle configuration. The purpose of this Trouble Shooting information is to provide a list of common causes to problem symptoms. For model-specific Trouble Shooting, refer to SUBJECT, DIAGNOSTIC, or TESTING articles available in the section(s) you are accessing.

BASIC SPARK PLUG TROUBLE SHOOTING CHARTS

CONDITION	POSSIBLE CAUSE	CORRECTION
Normal Spark Plug Condition	Light Tan or Gray deposits	No Action
	Electrode not burned or fouled	No Action
	Gap tolerance not changed	No Action
Cold Fouling or Carbon Deposits	Overrich air/fuel mixture	Adjust air/fuel mixture, see ENGINE PERFORMANCE section
	Faulty choke	Replace choke assembly, see ENGINE PERFORMANCE section
	Clogged air filter	Clean and/or replace air filter
	Incorrect idle speed or dirty carburetor	Reset idle speed and/or clean carburetor
	Faulty ignition wires	Replace ignition wiring
	Prolonged operation at idle	Shut engine off during long idle
	Sticking valves or worn valve guide seals	Check valve train
Wet Fouling or Oil Deposits	Worn rings and pistons	Install new rings and pistons

	Excessive cylinder wear	Rebore or replace block
	Excessive valve guide clearance	Worn or loose bearing
Gap Bridged	Deposits in combustion chamber becoming fused to electrode	Clean combustion chamber of deposits
Blistered Electrode	Engine overheating	Check cooling system
	Wrong type of fuel	Replace with correct fuel
	Loose spark plugs	Retighten spark plugs
	Over-advanced ignition timing	Reset ignition timing see ENGINE PERFORMANCE
Pre-Ignition or Melted Electrodes	Incorrect type of fuel	Replace with correct fuel
	Incorrect ignition timing	Reset ignition timing see ENGINE PERFORMANCE
	Burned valves	Replace valves
	Engine Overheating	Check cooling system
	Wrong type of spark plug, too hot	Replace with correct spark plug, see ENGINE PERFORMANCE
Chipped Insulators	Severe detonation	Check for over-advanced timing or combustion
	Improper gapping procedure	Re-gap spark plugs
Rust Colored Deposits	Additives in unleaded fuel	Try different fuel brand
Water In Combustion Chamber	Blown head gasket or cracked head	Repair or replace head or head gasket

NOTE: Before diagnosing an electronic ignition system, ensure that all wiring is connected properly between distributor, wiring connector and spark plugs. Ignition problem will show up either as: Engine Will Not Start or Engine Runs Rough.

BASIC ELECTRONIC IGNITION TROUBLE SHOOTING CHARTS

CONDITION	POSSIBLE CAUSE	CORRECTION
Engine Won't Start	Open circuit between distributor and bulkhead connector	Repair circuit
	Open circuit between bulkhead connector and	Repair circuit

ignition switch

Open circuit between
ignition switch and
starter solenoid

Repair circuit

Engine Runs
Rough

Fuel lines leaking or
clogged

Tighten fitting,
remove restriction

Initial timing incorrect

Reset ignition timing
see ENGINE PERFORMANCE

Centrifugal advance
malfunction

Repair distributor
advance

Defective spark plugs or
wiring

Replace plugs or plug
wiring

Component Failure

Spark arc-over on cap,
rotor or coil

Replace cap, rotor or
or coil

Defective pick-up coil

Replace pick-up coil

Defective ignition coil

Replace ignition coil

Defective vacuum unit

Replace vacuum unit

Defective control module

Replace control module

BASIC ELECTRONIC IGNITION TROUBLE SHOOTING CHARTS - USING OSCILLOSCOPE PATTERNS

CONDITION

POSSIBLE CAUSE

CORRECTION

Firing Voltage
Lines are the Same,
but Abnormally High

Retarded ignition timing

Reset ignition
timing, see ENGINE
PERFORMANCE section

Fuel mixture too lean

Readjust carburetor,
see ENGINE PERFORMANCE

High resistance in coil
wire

Replace coil wire

Corrosion in coil tower
terminal

Clean and/or replace
coil

Corrosion in distributor
coil terminal

Clean and/or replace
distributor cap

Firing Voltage
Lines are the Same
but Abnormally Low

Fuel mixture too rich

Readjust carburetor,
see ENGINE PERFORMANCE

Breaks in coil wire causing
arcing

Replace coil wire

Cracked coil tower causing
arcing

Replace coil

Low coil output

Replace coil

Low engine compression

Determine cause and

		repair
One or More, But Not All Firing Voltage Lines are Higher Than Others	Carburetor idle mixture not balanced	Readjust carburetor, see ENGINE PERFORMANCE
	EGR valve stuck open	Clean and/or replace valve
	High resistance in spark plug wires	Replace spark plug wires
	Cracked or broken spark plug insulator	Replace spark plugs
	Intake vacuum leak	Repair leak
	Defective spark plugs	Replace spark plugs
	Corroded spark plug terminals	Replace spark plugs
One or More, But Not All Firing Voltage Lines Are Lower Than Others	Carburetor idle mixture not balanced	Readjust carburetor, see ENGINE PERFORMANCE
	Breaks in plug wires causing arcing	Replace plug wires
	Cracked coil tower causing arcing	Replace coil
	Low compression	Determine cause and repair
	Defective spark plugs	Replace spark plugs
	Corroded spark plugs	Replace spark plugs
Cylinders Not Firing	Cracked distributor cap terminals	Replace distributor cap
	Shorted spark plug wire	Determine cause and repair
	Mechanical problem in engine	Determine cause and repair
	Defective spark plugs	Replace spark plugs
	Spark plugs fouled	Replace spark plugs

BASIC DRIVEABILITY PROBLEMS TROUBLE SHOOTING TABLE

CONDITION	POSSIBLE CAUSE	CORRECTION
Hard Starting	Binding carburetor linkage	Eliminate binding
	Binding choke linkage	Eliminate binding
	Binding choke piston	Eliminate binding
	Restricted choke vacuum	Check vacuum lines for blockage

Worn or dirty needle valve and seat	Clean carburetor, see ENGINE PERFORMANCE
Float sticking	Readjust or replace float see the ENGINE PERFORMANCE section
Incorrect choke adjustment	Reset choke adjustment see ENGINE PERFORMANCE
Defective coil	Replace coil
Improper spark plug gap	Regap spark plugs
Incorrect ignition timing	Reset ignition timing see ENGINE PERFORMANCE

Detonation	Over-advanced ignition timing	Reset ignition timing see ENGINE PERFORMANCE
	Defective spark plugs	Replace spark plugs
	Fuel lines clogged	Clean fuel lines
	EGR system malfunction	Check and repair EGR system
	PCV system malfunction	Repair PCV system
	Vacuum leaks	Check and repair vacuum system
	Loose fan belts	Tighten or replace fan belts, see ENGINE PERFORMANCE
	Restricted airflow	Remove restriction
Vacuum advance malfunction	Check distributor operation	

Dieseling	Binding carburetor linkage	Eliminate binding
	Binding throttle linkage	Eliminate blinding
	Binding choke linkage or fast idle cam	Eliminate binding
	Defective idle solenoid	Replace idle solenoid see ENGINE PERFORMANCE
	Improper base idle speed	Reset idle speed, see see ENGINE PERFORMANCE
	Incorrect ignition timing	Reset ignition timing see ENGINE PERFORMANCE
	Incorrect idle mixture setting	Reset idle mixture, see ENGINE PERFORMANCE

Faulty Acceleration	Incorrect ignition timing	Reset ignition timing see ENGINE PERFORMANCE
---------------------	---------------------------	--

	Engine cold and choke too lean	Adjust choke and allow engine to warm-up
	Defective spark plugs	Replace spark plugs
	Defective coil	Replace coil
Faulty Low Speed Operation	Clogged idle transfer slots	Clean idle transfer slots, see FUEL
	Restricted idle air bleeds and passages	Disassemble and clean carburetor, see FUEL
	Clogged air cleaner	Replace air filter
	Defective spark plugs	Replace spark plugs
	Defective ignition wires	Replace ignition wire see ENGINE PERFORMANCE
	Defective distributor cap	Replace distributor cap
Faulty High Speed Operation	Incorrect ignition timing	Reset ignition timing see ENGINE PERFORMANCE
	Defective distributor centrifugal advance	Replace advance mechanism
	Defective distributor vacuum advance	Replace advance unit
	Incorrect spark plugs or plug gap	Check gap and/or replace spark plugs
	Faulty choke operation	Check choke and repair as required
	Clogged vacuum passages	Remove restrictions
	Improper size or clogged main jet	Check jet size and clean, see FUEL
	Restricted air cleaner	Check filter and replace as necessary
	Defective distributor cap, rotor or coil	Replace cap, rotor or coil
Misfire at All Speeds	Defective spark plugs	Replace spark plugs
	Defective spark plug wires	Replace spark plug wires
	Defective distributor cap, rotor, or coil	Replace cap, rotor, or coil
	Cracked or broken vacuum hoses	Replace vacuum hoses

	Vacuum leaks	Repair vacuum leaks
	Fuel lines clogged	Remove restriction
Hesitation	Cracked or broken vacuum hoses	Replace vacuum hoses
	Vacuum leaks	Repair Vacuum leaks
	Binding carburetor linkage	Eliminate binding
	Binding throttle linkage	Eliminate binding
	Binding choke linkage or fast idle cam	Eliminate binding
	Improper float setting	Readjust float setting, see FUEL
	Cracked or broken ignition wires	Replace ignition wires
Rough idle, Missing or Stalling	Incorrect curb idle or fast idle speed	Reset idle speed, see see ENGINE PERFORMANCE
	Incorrect basic timing	Reset ignition timing see ENGINE PERFORMANCE
	Improper idle mixture adjustment	Reset idle mixture, see ENGINE PERFORMANCE
	Improper feedback system operation	Check feedback system see ENGINE PERFORMANCE
	Incorrect spark plug gap	Reset spark plug gap, see ENGINE PERFORMANCE
	Moisture in ignition components	Dry components
	Loose or broken ignition wires	Replace ignition wires
	Damaged distributor cap or or rotor	Replace distributor cap or rotor
	Faulty ignition coil	Replace ignition coil
	Fuel filter clogged or worn	Replace fuel filter
	Damaged idle mixture screw	Replace idle mixture screw, see FUEL
	Improper fast idle cam adjustment	Reset fast idle cam adjustment, see TUNE-see ENGINE PERFORMANCE
	Improper EGR valve operation	Replace EGR valve
	Faulty PCV valve air flow	Replace PCV valve
	Choke binding or improper choke setting	Reset choke or eliminate binding

Vacuum leak	Repair vacuum leak
Improper float bowl fuel level	Reset float adjustment, see FUEL
Clogged air bleed or idle passages	Clean carburetor passages, see FUEL
Clogged or worn air cleaner filter	Replace air filter
Faulty choke vacuum diaphragm	Replace diaphragm, see ENGINE PERFORMANCE
Exhaust manifold heat valve inoperative	Replace heat valve
Improper distributor spark advance	Check distributor operation
Leaking valves or valve components	Check and repair valvetrain
Improper carburetor mounting	Remove and remount carburetor
Excessive play in distributor shaft	Replace distributor
Loose or corroded wiring connections	Repair or replace as required

Engine Surges	Improper PCV valve airflow	Replace PCV valve
	Vacuum leaks	Repair vacuum leaks
	Clogged air bleeds	Remove restriction
	EGR valve malfunction	Replace EGR valve
	Restricted air cleaner filter	Replace air filter
	Cracked or broken vacuum hoses	Replace vacuum hoses
	Cracked or broken ignition wires	Replace ignition wires
	Vacuum advance malfunction	Check unit and replace as necessary
Defective or fouled spark plugs	Replace spark plugs	

Ping or Spark Knock	Incorrect ignition timing	Reset ignition timing see ENGINE PERFORMANCE
	Distributor centrifugal or vacuum advance malfunction	Check operation and replace as necessary
	Carburetor setting too lean	Readjust mixture

		setting, see ENGINE PERFORMANCE
	Vacuum leak	Eliminate vacuum leak
	EGR valve malfunction	Replace EGR valve
Poor Gasoline Mileage	Cracked or broken vacuum hoses	Replace vacuum hoses
	Vacuum leaks	Repair vacuum leaks
	Defective ignition wires	Replace wires
	Incorrect choke setting	Readjust setting, see ENGINE PERFORMANCE
	Defective vacuum advance	Replace vacuum advance
	Defective spark plugs	Replace spark plugs
	Binding carburetor power piston	Eliminate binding
	Dirt in carburetor jets	Clean and/or replace jets
	Incorrect float adjustment	Readjust float setting, see FUEL
	Defective power valve	Replace power valve, see ENGINE PERFORMANCE
	Incorrect idle speed	Readjust idle speed
Engine Stalls	Improper float level	Readjust float level
	Leaking needle valve and seat	Replace needle valve and seat
	Vacuum leaks	Eliminate vacuum leaks

VACUUM PUMP - DIESEL TROUBLE SHOOTING

NOTE: This is GENERAL information. This article is not intended to be specific to any unique situation or individual vehicle configuration. The purpose of this Trouble Shooting information is to provide a list of common causes to problem symptoms. For model-specific Trouble Shooting, refer to SUBJECT, DIAGNOSTIC, or TESTING articles available in the section(s) you are accessing.

NOTE: Diesel engines mechanical diagnosis is the same as gasoline engines for items such as noisy valves, bearings, pistons, etc. The following trouble shooting covers only items pertaining to diesel engines.

VACUUM PUMP (DIESEL) TROUBLE SHOOTING CHART

CONDITION	POSSIBLE CAUSE	CORRECTION
-----------	----------------	------------

Excessive Noise	Loose pump-to-drive assembly screws	Tighten screws
	Loose tube on pump assembly	Tighten tube
	Valves not functioning properly	Replace valves
Oil Leakage	Loose end plug	Tighten end plug
	Bad seal crimp	Remove and re-crimp seal

MANUAL TRANSMISSION

MANUAL TRANSMISSION TROUBLE SHOOTING

NOTE: This is GENERAL information. This article is not intended to be specific to any unique situation or individual vehicle configuration. The purpose of this Trouble Shooting information is to provide a list of common causes to problem symptoms. For model-specific Trouble Shooting, refer to SUBJECT, DIAGNOSTIC, or TESTING articles available in the section(s) you are accessing.

MANUAL TRANSMISSION/TRANSAXLE TROUBLE SHOOTING

Condition	Possible Cause
Noisy In Forward Gears	.Low gear oil level, .Loose bell housing bolts, .Worn bearings or gears
Clunk On Deceleration (FWD Only)	.Loose engine mounts, .Worn inboard CV joints, .Worn differential pinion shaft, .Side gear hub counterbore in case worn oversize
Gear Clash When Shifting Forward Gears	.Clutch Out Of Adjustment, .Shift linkage damaged or out of adjustment, .Gears or synchronizers damaged, .Low gear oil level
Transmission Noisy When Moving (RWD Only) Quiet In Neutral With Clutch Engaged	.Worn rear outputshaft bearing
Gear Rattle	.Worn bearings, .Wrong gear oil, .Low gear oil, .Worn gears
Steady Ticking At Idle (Increases With RPM)	.Broken tooth on gear
Gear Clash When Shifting Forward Gears	.Worn or broken synchronizers
Loud Whine In Reverse	.Normal condition (1)

Noise When Stepping On Clutch	.Bad release bearing, .Worn pilot bearing
Ticking Or Screeching As Clutch Is Engaged	.Faulty release bearing, .Uneven pressure plate fingers
Click Or Snap When Clutch Is Engaged	.Worn clutch fork, .Worn or broken front bearing retainer
Transmission Shifts Hard	.Clutch not releasing, .Shift mechanism binding, .Clutch installed backwards
Will Not Shift Into One Gear, Shifts Into All Others	.Bent shift fork, .Worn detent balls
Locked Into Gear, Cannot Shift	.Clutch adjustment, .Worn detent balls
Transmission Jumps Out Of Gear	.Pilot bearing worn, .Bent shift fork, .Worn gear teeth or face .Excessive gear train end play .Worn synchronizers .Missing detent ball spring .Shift mechanism worn or out of adjustment .Engine or transmission mount bolts loose or out of adjustment .Transmission not aligned
Shift Lever Rattle	.Worn shift lever or detents .Worn shift forks .Worn synchronizers sleeve
Shift Lever Hops Under Acceleration	.Worn engine or transmission mounts

(1) - Most units use spur cut gears in reverse and are noisy

POWERTRAIN

CLUTCH TROUBLE SHOOTING

NOTE: This is GENERAL information. This article is not intended to be specific to any unique situation or individual vehicle configuration. The purpose of this Trouble Shooting information is to provide a list of common causes to problem symptoms. For model-specific Trouble Shooting, refer to SUBJECT, DIAGNOSTIC, or TESTING articles available in the section(s) you are accessing.

BASIC CLUTCH TROUBLE SHOOTING CHART

CONDITION	POSSIBLE CAUSE	CORRECTION
Chattering or Grabbing	Incorrect clutch adjustment	Adjust clutch
	Oil, grease or glaze on facings	Disassemble and clean or replace
	Loose "U" joint flange	See DRIVE AXLES article
	Worn input shaft spline	Replace input shaft
	Binding pressure plate	Replace pressure plate
	Binding release lever	See CLUTCH article
	Binding clutch disc hub	Replace clutch disc
	Unequal pressure plate contact	Replace worn/misaligned components
	Loose/bent clutch disc	Replace clutch disc
	Incorrect transmission alignment	Realign transmission
	Worn pressure plate, disc or flywheel	Replace damaged components
	Broken or weak pressure springs	Replace pressure plate
	Sticking clutch pedal	Lubricate clutch pedal & linkage
Failure to Release	Incorrect clutch disc facing	Replace clutch disc
	Engine loose in chassis	Tighten all mounting bolts
	Oil or grease on clutch facings	Clean or replace clutch disc
	Incorrect release lever or pedal adjustment	See CLUTCH article
	Worn or broken clutch facings	Replace clutch disc
	Bent clutch disc or pressure plate	Replace damaged components
	Clutch disc hub binding on input shaft	Clean or replace clutch disc and/or input shaft
Binding pilot bearing	Replace pilot bearing	
Sticking release bearing sleeve	Replace release bearing and/or sleeve	
Binding clutch cable	See CLUTCH article	

	Defective clutch master	Replace master cylinder
	Defective clutch slave	Replace slave cylinder
	Air in hydraulic system	Bleed hydraulic system
Rattling	Weak or broken release lever spring	Replace spring and check alignment
	Damaged pressure plate	Replace pressure plate
	Broken clutch return spring	Replace return spring
	Worn splines on clutch disc or input shaft	Replace clutch disc and/or input shaft
	Worn clutch release bearing	Replace release bearing
	Dry or worn pilot bearing	Lubricate or replace pilot bearing
	Unequal release lever contact	Align or replace release lever
	Incorrect pedal free play	Adjust free play
	Warped or damaged clutch disc	Replace damaged components
Slipping	Pressure springs worn or	Release pressure plate
	Oily, greasy or worn facings	Clean or replace clutch disc
	Incorrect clutch alignment	Realign clutch assembly
	Warped clutch disc or pressure plate	Replace damaged components
	Binding release levers or clutch pedal	Lubricate and/or replace release components
Squeaking	Worn or damaged release	Replace release bearing
	Dry or worn pilot or release bearing	Lubricate or replace assembly
	Pilot bearing turning in crankshaft	Replace pilot bearing and/or crankshaft
	Worn input shaft bearing	Replace bearing and seal
	Incorrect transmission alignment	Realign transmission
	Dry release fork between pivot	Lubricate release fork and pivot
Heavy and/or Stiff Pedal	Sticking release bearing sleeve	Replace release bearing and/or sleeve

	Dry or binding clutch pedal hub	Lubricate and align components
	Floor mat interference with pedal	Lay mat flat in proper area
	Dry or binding ball/fork pivots	Lubricate and align components
	Faulty clutch cable	Replace clutch cable
Noisy Clutch Pedal	Faulty interlock switch	Replace interlock switch
	Self-adjuster ratchet noise	Lubricate or replace self-adjuster
	Speed control interlock switch	Lubricate or replace interlock switch
Clutch Pedal Sticks Down	Binding clutch cable	See CLUTCH article
	Springs weak in pressure plate	Replace pressure plate
	Binding in clutch linkage	Lubricate and free linkage
Noisy	Dry release bearing	Lubricate or replace release bearing
	Dry or worn pilot bearing	Lubricate or replace bearing
	Worn input shaft bearing	Replace bearing
Transmission Click	Weak springs in pressure plate	Replace pressure plate
	Release fork loose on ball stud	Replace release fork and/or ball stud
	Oil on clutch disc damper	Replace clutch disc
	Broken spring in slave cylinder	Replace slave cylinder

DRIVE AXLE - NOISE DIAGNOSIS

Unrelated Noises

Some driveline trouble symptoms are also common to the engine, transmission, wheel bearings, tires, and other parts of the vehicle. Ensure cause of trouble actually is in the drive axle before adjusting, repairing, or replacing any of its parts.

Non-Drive Axle Noises

A few conditions can sound just like drive axle noise and have to be considered in pre-diagnosis. The 4 most common noises are exhaust, tires, CV/universal joints and wheel trim rings.

In certain conditions, the pitch of the exhaust gases may sound like gear whine. At other times, it may be mistaken for a wheel bearing rumble.

Tires, especially radial and snow, can have a high-pitched tread whine or roar, similar to gear noise. Also, some non-standard tires with an unusual tread construction may emit a roar or whine.

Defective CV/universal joints may cause clicking noises or excessive driveline play that can be improperly diagnosed as drive axle problems.

Trim and moldings also can cause a whistling or whining noise. Ensure none of these components are causing the noise before disassembling the drive axle.

Gear Noise

A "howling" or "whining" noise from the ring and pinion gear can be caused by an improper gear pattern, gear damage, or improper bearing preload. It can occur at various speeds and driving conditions, or it can be continuous.

Before disassembling axle to diagnose and correct gear noise, make sure that tires, exhaust, and vehicle trim have been checked as possible causes.

Chuckle

This is a particular rattling noise that sounds like a stick against the spokes of a spinning bicycle wheel. It occurs while decelerating from 40 MPH and usually can be heard until vehicle comes to a complete stop. The frequency varies with the speed of the vehicle.

A chuckle that occurs on the driving phase is usually caused by excessive clearance due to differential gear wear, or by a damaged tooth on the coast side of the pinion or ring gear. Even a very small tooth nick or a ridge on the edge of a gear tooth is enough the cause the noise.

This condition can be corrected simply by cleaning the gear tooth nick or ridge with a small grinding wheel. If either gear is damaged or scored badly, the gear set must be replaced. If metal has broken loose, the carrier and housing must be cleaned to remove particles that could cause damage.

Knock

This is very similar to a chuckle, though it may be louder, and occur on acceleration or deceleration. Knock can be caused by a gear tooth that is damaged on the drive side of the ring and pinion gears. Ring gear bolts that are hitting the carrier casting can cause knock. Knock can also be due to excessive end play in the axle shafts.

Clunk

Clunk is a metallic noise heard when an automatic transmission is engaged in Reverse or Drive, or when throttle is applied or released. It is caused by backlash somewhere in the driveline, but not necessarily in the axle. To determine whether driveline clunk is caused by the axle, check the total axle backlash as follows:

- 1) Raise vehicle on a frame or twinpost hoist so that drive wheels are free. Clamp a bar between axle companion flange and a part of the frame or body so that flange cannot move.

- 2) On conventional drive axles, lock the left wheel to keep it from turning. On all models, turn the right wheel slowly until it is felt to be in Drive condition. Hold a chalk marker on side of tire about 12" from center of wheel. Turn wheel in the opposite direction until it is again felt to be in Drive condition.

- 3) Measure the length of the chalk mark, which is the total

axle backlash. If backlash is one inch or less, drive axle is not the source of clunk noise.

Bearing Whine

Bearing whine is a high-pitched sound similar to a whistle. It is usually caused by malfunctioning pinion bearings. Pinion bearings operate at drive shaft speed. Roller wheel bearings may whine in a similar manner if they run completely dry of lubricant. Bearing noise will occur at all driving speeds. This distinguishes it from gear whine, which usually comes and goes as speed changes.

Bearing Rumble

Bearing rumble sounds like marbles being tumbled. It is usually caused by a malfunctioning wheel bearing. The lower pitch is because the wheel bearing turns at only about 1/3 of drive shaft speed.

Chatter On Turns

This is a condition where the entire front or rear of vehicle vibrates when vehicle is moving. The vibration is plainly felt as well as heard. Extra differential thrust washers installed during axle repair can cause a condition of partial lock-up that creates this chatter.

Axle Shaft Noise

Axle shaft noise is similar to gear noise and pinion bearing whine. Axle shaft bearing noise will normally distinguish itself from gear noise by occurring in all driving modes (Drive, cruise, coast and float), and will persist with transmission in Neutral while vehicle is moving at problem speed.

If vehicle displays this noise condition, remove suspect axle shafts, replace wheel seals and install a new set of bearings. Re-evaluate vehicle for noise before removing any internal components.

Vibration

Vibration is a high-frequency trembling, shaking or grinding condition (felt or heard) that may be constant or variable in level and can occur during the total operating speed range of the vehicle.

The types of vibrations that can be felt in the vehicle can be divided into 3 main groups:

- * Vibrations of various unbalanced rotating parts of the vehicle.
- * Resonance vibrations of the body and frame structures caused by rotating of unbalanced parts.
- * Tip-in moans of resonance vibrations from stressed engine or exhaust system mounts or driveline flexing modes.

DRIVE AXLE - RWD TROUBLE SHOOTING

NOTE: This is GENERAL information. This article is not intended to be specific to any unique situation or individual vehicle configuration. The purpose of this Trouble Shooting information is to provide a list of common causes to problem symptoms. For model-specific Trouble Shooting, refer to SUBJECT, DIAGNOSTIC, or TESTING articles available in the section(s) you are accessing. For definitions of listed noises or sounds, see DRIVE AXLE - NOISE DIAGNOSIS under POWERTRAIN.

DRIVE AXLE (RWD) TROUBLE SHOOTING

CONDITION	POSSIBLE CAUSE	CORRECTION
-----------	----------------	------------

Knocking or Clunking

Differential Side Gear Clearance	Check Clearance
Worn Pinion Shaft	Replace Pinion Shaft
Axle Shaft End Play	Check End Play
Missing Gear Teeth	Check Differential/ Replace Gear
Wrong Axle Backlash	Check Backlash
Misaligned Driveline	Realign Driveline

Clinking During Engagement

Side Gear Clearance	Check Clearance
Ring and Pinion Backlash	Check Backlash
Worn/Loose Pinion Shaft	Replace Shaft/Bearing
Bad "U" Joint	Replace "U" Joint
Sticking Slip Yoke	Lube Slip Yoke
Broken Rear Axle Mount	Replace Mount
Loose Drive Shaft Flange	Check Flange

Click/Chatter On Turns

Differential Side Gear Clearance	Check Clearance
Wrong Turn On Plates (1)	Replace Clutch Plates
Wrong Differential Lubricant (1)	Change Lubricant

Knock Or Click

Flat Spot on Rear Wheel Bearing	Replace Wheel Bearing
---------------------------------	-----------------------

Low Vibration At All Speeds

Faulty Wheel Bearing	Replace Wheel Bearing
Faulty "U" Joint	Replace "U" Joint
Faulty Drive Shaft	Balance Drive Shaft
Faulty Companion Flange	Replace Flange
Faulty Slip Yoke Flange	Replace Flange

(1) - Limited slip differential only.

FWD AXLE SHAFTS & CV JOINTS TROUBLE SHOOTING

NOTE: This is GENERAL information. This article is not intended to be specific to any unique situation or individual vehicle configuration. The purpose of this Trouble Shooting information is to provide a list of common causes to

problem symptoms. For model-specific Trouble Shooting, refer to SUBJECT, DIAGNOSTIC, or TESTING articles available in the section(s) you are accessing.

BASIC FWD AXLE SHAFTS & CV JOINTS TROUBLE SHOOTING CHART

CONDITION	POSSIBLE CAUSE
Grease Leaks	CV boot torn or cracked
Clicking Noise on Cornering	Damaged outer CV
Clunk Noise on Acceleration	Damaged inner CV
Vibration or Shudder on Acceleration	Sticking, damaged or worn CV Misalignment or spring height

STEERING & SUSPENSION

MANUAL STEERING GEAR TROUBLE SHOOTING

NOTE: This is GENERAL information. This article is not intended to be specific to any unique situation or individual vehicle configuration. The purpose of this Trouble Shooting information is to provide a list of common causes to problem symptoms. For model-specific Trouble Shooting, refer to SUBJECT, DIAGNOSTIC, or TESTING articles available in the section(s) you are accessing.

BASIC MANUAL STEERING GEAR TROUBLE SHOOTING CHART

CONDITION	POSSIBLE CAUSE	CORRECTION
Rattle or Chucking Noise in Rack and Pinion	Rack and pinion mounting bracket loose	Tighten all mounting bolts
	Lack of/or incorrect lubricant	Correct as necessary
	Steering gear mounting bolts loose	Tighten all mounting bolts
Excessive Play	Front wheel bearing improperly adjusted	See FRONT SUSPENSION article
	Loose or worn steering linkage	See STEERING LINKAGE article
	Loose or worn steering gear shift	See MANUAL STEERING GEAR article
	Steering arm loose on gear shaft	See MANUAL STEERING GEAR article
	Steering gear housing bolts loose	Tighten all mounting bolts
	Steering gear adjustment too loose	See MANUAL STEERING GEAR article
	Steering arms loose on	Tighten and check

knuckles	steering linkage
Rack and pinion mounting loose	Tighten all mounting bolts
Rack and pinion out of adjustment	See adjustment in STEERING article
Tie rod end loose	Tighten and check steering linkage
Excessive Pitman shaft-to-ball nut lash	Repair as necessary

Poor Returnability	Lack of lubricant in ball joint or linkage	Lubricate and service systems
	Binding in linkage or ball joints	See STEERING LINKAGE and SUSPENSION article
	Improper front end alignment	See WHEEL ALIGNMENT article
	Improper tire pressure	Inflate to proper pressure
	Tie rod binding	Inflate to proper pressure
	Shaft seal rubbing shaft	See STEERING COLUMN article

Excessive Vertical Motion	Improper tire pressure	Inflate to proper pressure
	Tires, wheels or rotors out of balance	Balance tires then check wheels and rotors
	Worn or faulty shock absorbers	Check and replace if necessary
	Loose tie rod ends or steering	Tighten or replace if necessary
	Loose or worn wheel bearings	See SUSPENSION article

Steering Pulls to One Side	Improper tire pressure	Inflate to proper pressure
	Front tires are different sizes	Rotate or replace if necessary
	Wheel bearings not adjusted properly	See FRONT SUSPENSION article
	Bent or broken suspension components	See FRONT SUSPENSION article
	Improper wheel alignment	See WHEEL ALIGNMENT article

	Brakes dragging	See BRAKES article
Instability	Low or uneven tire pressure	Inflate to proper pressure
	Loose or worn wheel bearings	See FRONT SUSPENSION article
	Loose or worn idler arm bushing	See FRONT SUSPENSION article
	Loose or worn strut bushings	See FRONT SUSPENSION article
	Incorrect front wheel alignment	See WHEEL ALIGNMENT article
	Steering gear not centered	See MANUAL STEERING GEARS article
	Springs or shock	Check and replace if necessary
	Improper cross shaft	See MANUAL STEERING GEARS article

POWER STEERING TROUBLE SHOOTING

NOTE: This is GENERAL information. This article is not intended to be specific to any unique situation or individual vehicle configuration. The purpose of this Trouble Shooting information is to provide a list of common causes to problem symptoms. For model-specific Trouble Shooting, refer to SUBJECT, DIAGNOSTIC, or TESTING articles available in the section(s) you are accessing.

BASIC POWER STEERING TROUBLE SHOOTING CHART

CONDITION	POSSIBLE CAUSE	CORRECTION
Rattle or Chucking Noise	Pressure hoses touching engine parts	Adjust to proper clearance
	Loose Pitman shaft	Adjust or replace if necessary
	Tie rods ends or Pitman arm loose	Tighten and check system
	Rack and pinion mounts loose	Tighten all mounting bolts
	Free play in worm and	See POWER STEERING GEAR article
	Loose sector shaft or thrust bearing adjustment	See POWER STEERING GEAR
	Free play in pot coupling	See STEERING COLUMN article

	Worn shaft serrations	See STEERING COLUMN article
Growl in Steering Pump	Excessive pressure in hoses	Restricted hoses, see POWER STEERING GEAR article
	Scored pressure plates	See POWER STEERING GEAR article
	Scored thrust plates or rotor	See POWER STEERING GEAR article
	Extreme wear of cam ring	See POWER STEERING GEAR article
Rattle in Steering Pump	Vanes not installed	See POWER STEERING PUMP article
	Vanes sticking in rotor	See POWER STEERING PUMP article
Swish noise in Pump	Defective flow control valve	See POWER STEERING PUMP article
Groan in Steering Pump	Air in fluid	See POWER STEERING PUMP article
	Poor pressure hose connection	Tighten and check, replace if necessary
Squawk When Turning	Damper "O" ring on valve spool cut	See POWER STEERING PUMP article
Moan or Whine in Pump	Pump shaft bearing scored	Replace bearing and fluid
	Air in fluid or fluid level low	See POWER STEERING PUMP article
	Hose or column grounded	Check and replace if necessary
	Cover "O" ring missing or damaged	See POWER STEERING PUMP article
	Valve cover baffle missing or damaged	See POWER STEERING PUMP article
	Interference of components in pump	See POWER STEERING PUMP article
	Loose or poor bracket alignment	Correct or replace if necessary
Hissing When Parking	Internal leakage in steering gear	Check valved assembly first
Chirp in Steering Pump	Loose or worn power steering belt	Adjust or replace if necessary
Buzzing When Not Steering	Noisy pump	See POWER STEERING PUMP article

	Free play in steering shaft bearing	See STEERING COLUMN article
	Bearing loose on shaft serrations	See STEERING COLUMN article
Clicking Noise in Pump	Pump slippers too long	See POWER STEERING PUMP article
	Broken slipper springs	See POWER STEERING PUMP article
	Excessive wear or nicked rotors	See POWER STEERING PUMP article
	Damaged cam contour	See POWER STEERING PUMP article
Poor Return of Wheel	Wheel rubbing against turn signal	See STEERING COLUMN SWITCHES article
	Flange rubbing steering gear adjuster	See STEERING COLUMN article
	Tight or frozen steering shaft bearing	See STEERING COLUMN article
	Steering gear out of adjustment	See POWER STEERING GEAR article
	Sticking or plugged spool valve	See POWER STEERING PUMP article
	Improper front end alignment	See WHEEL ALIGNMENT article
	Wheel bearings worn or loose	See FRONT SUSPENSION article
	Ties rods or ball joints binding	Check and replace if necessary
	Intermediate shaft joints binding	See STEERING COLUMN article
	Kinked pressure hoses	Correct or replace if necessary
	Loose housing head spanner nut	See POWER STEERING GEAR article
	Damaged valve lever	See POWER STEERING GEAR article
	Sector shaft adjusted too tight	See ADJUSTMENTS in POWER STEERING GEAR article
	Worm thrust bearing adjusted too tight	See ADJUSTMENTS in POWER STEERING GEAR article
Reaction ring sticking in cylinder	See POWER STEERING GEAR article	

Reaction ring sticking in housing head	See POWER STEERING GEAR article
Steering pump internal leakage	See POWER STEERING PUMP article
Steering gear-to-column misalignment	See STEERING COLUMN article
Lack of lubrication in linkage	Service front suspension
Lack of lubrication in ball joints	Service front suspension

Increased Effort When Turning Wheel Fast Foaming, Milky Power Steering Fluid, Low Fluid Level or Low Pressure	High internal pump leakage	See POWER STEERING PUMP article
	Power steering pump belt slipping	Adjust or replace if necessary
	Low fluid level	Check and fill to proper level
	Engine idle speed too low	Adjust to correct setting
	Air in pump fluid system	See POWER STEERING PUMP article
	Pump output low	See POWER STEERING PUMP article
Steering gear malfunctioning	See POWER STEERING GEAR article	

Wheel Surges or Jerks	Low fluid level	Check and fill to proper level
	Loose fan belt	Adjust or replace if necessary
	Insufficient pump pressure	See POWER STEERING PUMP article
	Sticky flow control valve	See POWER STEERING PUMP article
	Linkage hitting oil pan at full turn	Replace bent components

Kick Back or Free Play	Air in pump fluid system	See POWER STEERING PUMP article
	Worn poppet valve in steering gear	See POWER STEERING PUMP article
	Excessive over center lash	See POWER STEERING GEAR article
	Thrust bearing out of adjustment	See POWER STEERING GEAR article

Free play in pot coupling	See POWER STEERING PUMP article
Steering gear coupling loose on shaft	See POWER STEERING PUMP article
Steering disc mounting bolts loose	Tighten or replace if necessary
Coupling loose on worm shaft	Tighten or replace if necessary
Improper sector shaft adjustment	See POWER STEERING GEAR article
Excessive worm piston side play	See POWER STEERING GEAR article
Damaged valve lever	See POWER STEERING GEAR article
Universal joint loose	Tighten or replace if necessary
Defective rotary valve	See POWER STEERING GEAR article

No Power When Parking

Sticking flow control valve	See POWER STEERING PUMP article
Insufficient pump pressure output	See POWER STEERING PUMP article
Excessive internal pump leakage	See POWER STEERING PUMP article
Excessive internal gear leakage	See POWER STEERING PUMP article
Flange rubs against gear adjust plug	See STEERING COLUMN article
Loose pump belt	Adjust or replace if necessary
Low fluid level	Check and add proper amount of fluid
Engine idle too low	Adjust to correct setting
Steering gear-to-column misaligned	See STEERING COLUMN article

No Power, Left Turn

Left turn reaction seal "O" ring worn	See POWER STEERING GEAR article
Left turn reaction seal damaged/missing	See POWER STEERING GEAR article
Cylinder head "O" ring damaged	See POWER STEERING PUMP article

No Power, Right Turns	Column pot coupling bottomed	See STEERING COLUMN article
	Right turn reaction seal "O" ring worn	See POWER STEERING GEAR article
	Right turn reaction seal damaged	See POWER STEERING GEAR article
	Internal leakage through piston end plug	See POWER STEERING GEAR article
	Internal leakage through side plugs	See POWER STEERING GEAR article
Lack of Effort in Turning	Left and/or right reaction seal sticking in cylinder head	Replace, see POWER STEERING GEAR article
Wanders to One Side	Front end alignment incorrect	See WHEEL ALIGNMENT article
	Unbalanced steering gear valve	See POWER STEERING GEAR article
Low Pressure Due to Steering Pump	Flow control valve stuck or inoperative	See POWER STEERING PUMP article
	Pressure plate not flat against cam ring	See POWER STEERING PUMP article
	Extreme wear of cam ring	Replace and check adjustments
	Scored plate, thrust plate or rotor	See POWER STEERING PUMP article
	Vanes not installed properly	See POWER STEERING PUMP article
	Vanes sticking in rotor slots	See POWER STEERING PUMP article
	Cracked/broken thrust or pressure plate	See POWER STEERING PUMP article

STEERING COLUMN TROUBLE SHOOTING

NOTE: This is GENERAL information. This article is not intended to be specific to any unique situation or individual vehicle configuration. The purpose of this Trouble Shooting information is to provide a list of common causes to problem symptoms. For model-specific Trouble Shooting, refer to SUBJECT, DIAGNOSTIC, or TESTING articles available in the section(s) you are accessing.

BASIC STEERING COLUMN TROUBLE SHOOTING CHART

CONDITION	POSSIBLE CAUSE	CORRECTION
Noise in Steering	Coupling pulled apart	See STEERING COLUMNS article

	Column not correctly aligned	See STEERING COLUMNS article
	Broken lower joint	Replace joint
	Horn contact ring not	See STEERING COLUMN article
	Bearing not lubricated	See STEERING COLUMN article
	Shaft snap ring not properly seated	Reseat or replace snap ring
	Plastic spherical joint not lubricated	See STEERING COLUMN article
	Shroud or housing loose	Tighten holding screws
	Lock plate retaining ring not seated	See STEERING COLUMN article
	Loose sight shield	Tighten holding screws
High Steering Shaft Effort	Column assembly misaligned	See STEERING COLUMN article
	Improperly installed dust shield	Adjust or replace
	Tight steering universal joint	See STEERING COLUMN article
High Shift Effort	Column is out of alignment	See STEERING COLUMN article
	Improperly installed dust shield	Adjust or replace
	Seals or bearings not lubricated	See STEERING COLUMNS article
	Mounting bracket screws too long	Replace with new shorter screws
	Burrs on shift tube	Remove burrs or replace tube
	Lower bowl bearing assembled wrong	See STEERING COLUMN article
	Shift tube bent or broken	Replace as necessary
Improper Trans. Shifting	Improper adjustment of shift levers	See STEERING COLUMN article
	Sheared shift tube joint	Replace as necessary
	Sheared lower shaft lever	Replace as necessary
	Improper shift lever adjustment	See STEERING COLUMN article

	Improper gate plate adjustment	See STEERING COLUMN article
Excess Play in Column	Instrument panel bracket bolts loose	Tighten bolts and check bracket
	Broken weld nut on jacket	See STEERING COLUMN article
	Instrument bracket capsule sheared	See STEERING COLUMN article
	Column bracket/jacket bolts loose	Tighten bolts and check bracket
Steering Locks in Gear	Release lever mechanism	See STEERING COLUMN article

SUSPENSION TROUBLE SHOOTING

NOTE: This is GENERAL information. This article is not intended to be specific to any unique situation or individual vehicle configuration. The purpose of this Trouble Shooting information is to provide a list of common causes to problem symptoms. For model-specific Trouble Shooting, refer to SUBJECT, DIAGNOSTIC, or TESTING articles available in the section(s) you are accessing.

BASIC SUSPENSION TROUBLE SHOOTING CHART

CONDITION	POSSIBLE CAUSE	CORRECTION
Front End Noise	Loose or worn wheel	See Wheel Bearing Adjustment in SUSPENSION
	Worn shocks or shock mountings	Replace struts or strut mountings
	Worn struts or strut mountings	Replace struts or strut mountings
	Loose or worn lower control arm	See SUSPENSION
	Loose steering gear-to-frame bolts	See STEERING
	Worn control arm bushings	See SUSPENSION
	Ball joints not lubricated	Lubricate ball joints & see Ball Joint Checking in SUSPENSION
Front Wheel Shake, Shimmy, or Vibration	Tires or wheels out of balance	Check tire balance
	Incorrect wheel alignment	See WHEEL ALIGNMENT
	Drive shaft unbalanced	Check drive shaft balance

	Loose or worn wheel bearings	See WHEEL ALIGNMENT
	Loose or worn tie rod ends	See SUSPENSION
	Worn upper ball joints	See Ball Joint Checking in SUSPENSION
	Worn shock absorbers	Replace shock absorbers
	Worn strut bushings	Replace strut bushings
Car Pulls to One Side	Mismatched or uneven tires	Check tire condition
	Broken or sagging springs	See SUSPENSION
	Loose or worn strut bushings	See SUSPENSION
	Improper wheel alignment	See WHEEL ALIGNMENT
	Improper rear axle alignment	Check rear axle alignment
	Power steering gear unbalanced	See STEERING
	Front brakes dragging	See BRAKES
Abnormal Tire Wear	Unbalanced tires	Check tire balance & rotation
	Sagging or broken springs	See SUSPENSION
	Incorrect front end alignment	See WHEEL ALIGNMENT
	Faulty shock absorbers	Replace shock absorbers
Scuffed Tires	Toe-In incorrect	See WHEEL ALIGNMENT
	Suspension arm bent or twisted	See appropriate SUSPENSION article
Springs Bottom or Sag	Bent or broken springs	See SUSPENSION
	Leaking or worn shock absorbers	Replace shock absorbers
	Frame misalignment	Check frame for damage
Spring Noises	Loose "U" Bolts	See SUSPENSION
	Loose or worn bushings	See SUSPENSION
	Worn or missing interliners	See SUSPENSION
Shock Absorber Noise	Loose shock mountings	Check & tighten mountings
	Worn bushings	Replace bushings

	Air in system	Bleed air from system
	Undercoating on shocks	Remove undercoating
Car Leans or Sways on Corners	Loose stabilizer bar	See SUSPENSION
	Faulty shocks or mountings	Replace shocks or mountings
	Broken or sagging springs	See SUSPENSION
Shock Absorbers Leaking	Worn seals or reservoir tube crimped	See SUSPENSION
Broken Springs	Loose "U" bolts	See SUSPENSION
	Inoperative shock absorbers	Replace shock absorbers

WHEEL ALIGNMENT TROUBLE SHOOTING

NOTE: This is GENERAL information. This article is not intended to be specific to any unique situation or individual vehicle configuration. The purpose of this Trouble Shooting information is to provide a list of common causes to problem symptoms. For model-specific Trouble Shooting, refer to SUBJECT, DIAGNOSTIC, or TESTING articles available in the section(s) you are accessing.

BASIC WHEEL ALIGNMENT TROUBLE SHOOTING CHART

CONDITION	POSSIBLE CAUSE	CORRECTION
Premature Tire Wear	Improper tire inflation	Check tire pressure
	Front alignment out of tolerance	See ALIGNMENT SPECS in WHEEL ALIGNMENT section
	Suspension components worn	See SUSPENSION section
	Steering system components worn	See STEERING section
	Improper standing height	See WHEEL ALIGNMENT
	Uneven or sagging springs	See SUSPENSION section
	Bent wheel	See WHEEL ALIGNMENT
	Improper torsion bar adjustment	See SUSPENSION section
	Loose or worn wheel bearings	See WHEEL BEARING ADJ. in SUSPENSION section
	Worn or defective shock	Replace shock absorbers
	Tires out of balance	Check tire balance
Pulls to One Side	Improper tire inflation	Check tire pressure
	Brake dragging	See BRAKE section

Mismatched tires	See WHEEL ALIGNMENT
Broken or sagging spring	See SUSPENSION section
Broken torsion bar	See SUSPENSION section
Power steering valve not centered	See STEERING section
Front alignment out of tolerance	See WHEEL ALIGNMENT section
Defective wheel bearing	See WHEEL BEARINGS in SUSPENSION section
Uneven sway bar links	See SUSPENSION section
Frame bent	Check for frame damage
Steering system bushing worn	See STEERING section

Hard Steering	Idler arm bushing too tight	See STEERING LINKAGE in STEERING section
	Ball joint tight or seized	See SUSPENSION section
	Steering linkage too tight	See STEERING LINKAGE in STEERING section
	Power steering fluid low	Add proper amount of fluid
	Power steering drive belt loose	See STEERING section
	Power steering pump defective	See STEERING section
	Steering gear out of adjustment	See STEERING section
	Incorrect wheel alignment	See WHEEL ALIGNMENT
	Damaged steering gear	See STEERING section
	Damaged suspension	See SUSPENSION section
Bent steering knuckle or supports	See SUSPENSION section	

Vehicle "Wanders"	Strut rod or control arm bushing worn	See SUSPENSION section
	Loose or worn wheel bearings	See WHEEL BEARINGS in SUSPENSION section
	Improper tire inflation	Check tire pressure
	Stabilizer bar missing or defective	See SUSPENSION section

	Wheel alignment out of tolerance	See Adjustment in WHEEL ALIGNMENT section
	Broken spring	See SUSPENSION section
	Defective shock absorbers	Replace shock absorbers
	Worn steering & suspension components	See SUSPENSION section
Front End Shimmy	Tire out of balance/round	Check tire balance
	Excessive wheel runout	See WHEEL ALIGNMENT
	Insufficient or improper caster	See WHEEL ALIGNMENT section
	Worn suspension or steering components	See SUSPENSION section
	Defective shock absorbers	Replace shock absorber
	Wheel bearings worn or loose	See WHEEL BEARING ADJ. in SUSPENSION section
	Power steering reaction Bracket loose	See STEERING section
	Steering gear box (rack) mounting loose	See STEERING section
	Steering gear adjustment loose	See STEERING section
Worn spherical joints	See SUSPENSION section	
Toe-In Not Adjustable	Lower control arm bent	See SUSPENSION section
	Frame bent	Check frame for damage
Camber Not Adjustable	Control arm bent	See SUSPENSION section
	Frame bent	Check frame for damage
	Hub & bearing not seated properly	See SUSPENSION section