

TOYOTA TECHNICAL SERVICE BULLETIN

REF.: BRAKES
NO.: BR94-002
DATE: FEBRUARY 7, 1994
MODEL: ALL MODELS

BRAKE VIBRATION AND / OR PULSATION

Page 1 of 6

This TSB outlines the causes of brake vibration and pulsation, as well as the best corrective measures to use.

CONTENTS

- 1) Symptoms of brake vibration and pulsation
- 2) Cause of vibration/pulsation problems
- 3) Advantages of using an on-car brake lathe
- 4) Rotor replacement and off-car brake lathe procedure

1) SYMPTOMS OF BRAKE VIBRATION AND PULSATION

Brake vibration problems generally involve one or both of two phenomena: body vibration and/or pedal pulsation.

A. BRAKE VIBRATION

Applying brakes causes vibration to occur in the instrument panel, steering column, steering wheel, and/or body of the vehicle (see Figure 1 below).

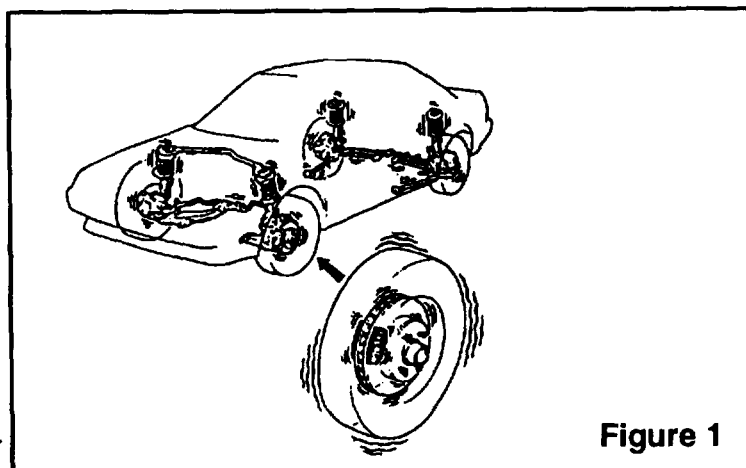

Index # 037245

TOYOTA MOTOR SALES U.S.A., INC.

We Support ASE Certification

B. PEDAL PULSATION

Applying brakes causes the brake pedal to pulsate. This brake pulsation sometimes causes the steering wheel to oscillate when the brakes are applied (see **Figure 2** below).

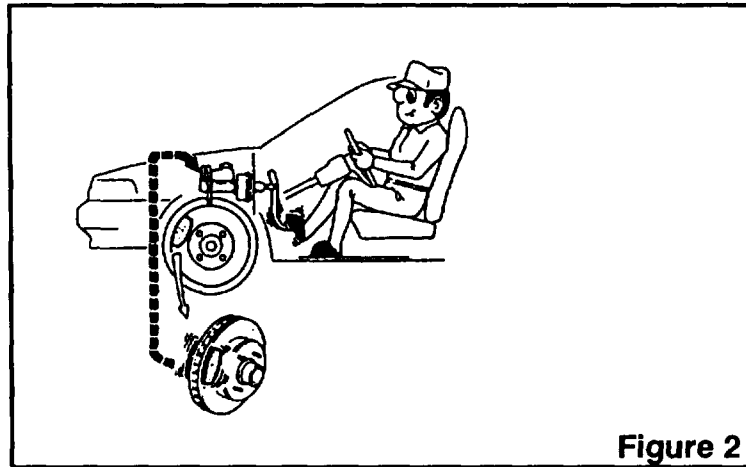

Figure 2

2) CAUSE OF VIBRATION/PULSATION PROBLEMS

Brake rotor thickness variation causes brake vibration due to changes in the braking force as thick/thin portions of the rotor pass the pads. Brake rotor thickness variation can be measured with a micrometer as shown in **Figure 3** below.

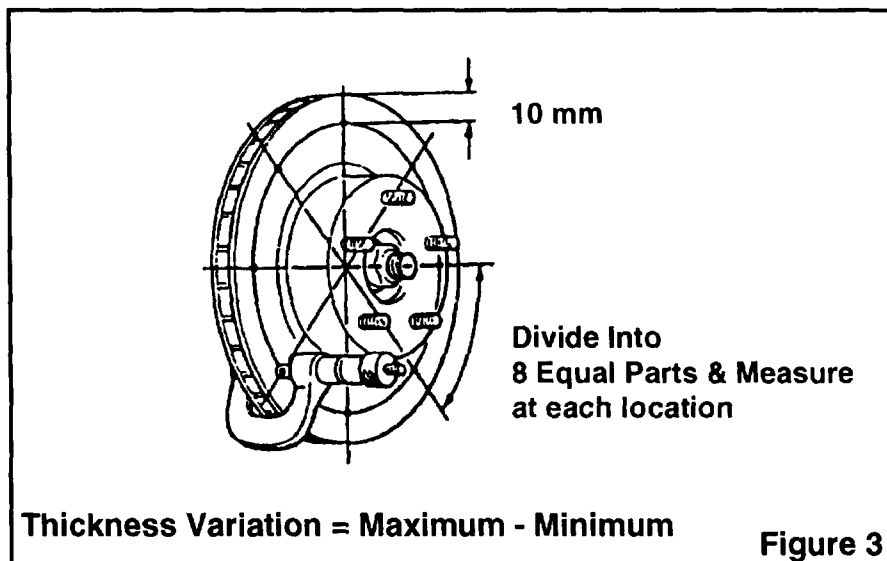
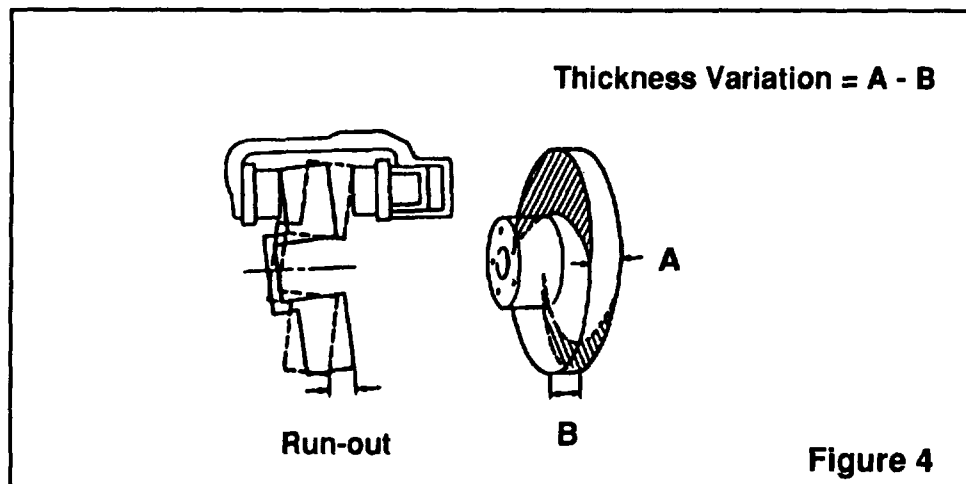

Figure 3

There are two factors which cause excessive rotor thickness variation:

A. ROTOR RUN-OUT

- **Rotor run-out** can be caused by poor mating of flanges between the hub and rotor when assembled as a unit. Manufacturing tolerance stack-up of the rotor and hub may also cause excessive rotor assembly run-out (**see Figure 4 below**).
- If there is rotor run-out, a portion of the rotor comes into contact with the brake pad on each rotor revolution. If left like this, the portion of the rotor that contacts the brake pad becomes worn, creating **thickness variation**.



B. EXCESSIVE RUST OR CORROSION ON ROTOR SURFACE

- Driving in areas where salt is applied to road surfaces for winter conditions can cause rust and corrosion when the vehicle is parked for an extended period of time. This occurs on the area where the brake pads are not in contact with the rotor.
- When a vehicle is driven with rusted rotors, the area with corrosion wears at a different rate than the non-corroded areas, resulting in excessive thickness variation.

3) Advantages Of Using An On-Car Brake Lathe

Toyota Motor Corporation Engineers strongly recommend that an on-car brake lathe be used for repairing brake vibration and pulsation. This method improves rotor and hub combined run-out, and is the preferred method when compared to rotor replacement and off-the-car rotor machining.

A. Technical Advantage of Caliper Mounted Brake Lathe

- Installing the brake lathe in the same position as the caliper results in minimal run-out relative to the caliper.
- Eliminating this run-out minimizes the pad grinding on the rotor and reduces rotor thickness variation.

B. Practical Use Benefits

- Resurfacing rotors on vehicles with rotor/hub assemblies (Land Cruiser, Truck) can be performed easily.
- Vehicles with corrosion between hub and rotor flanges can be machined without removing rotor from hub.

4) Rotor Replacement And Off-Car Brake Lathe Procedures

If an on-car brake lathe is not available at your dealership, it may be necessary to use an off-car lathe or replace rotors. In order to ensure proper brake vibration and pulsation repairs, pay close attention to the following precautions:

A. Off-Car Brake Lathe Precautions

- Perform routine maintenance of brake lathe components (clearance of arbor shaft to adapters may need to be repaired).
- Clean all adapters and shaft to maintain accuracy of equipment.
- When installing rotor to machine, clean mud, rust, and/or foreign material from the adapters and rotors.
- After installing rotor on machine, check rotor run-out using dial indicator. If run-out is excessive, determine the cause and correct it.
- Follow lathe manufacturer repair procedures. Do not cut excessive amounts off rotor during the first cut to save time.

Anytime a rotor is machined it must be measured for minimum rotor thickness. The thickness for the rotor is never to be less than minimum thickness as specified in the appropriate repair manual.

B. Installation of Rotor

- Check wheel bearing pre-load. If excessive movement is found, adjust bearing pre-load.
- Using a dial indicator, measure the rotor 10 mm from the outside edge (see Figure 5 below).

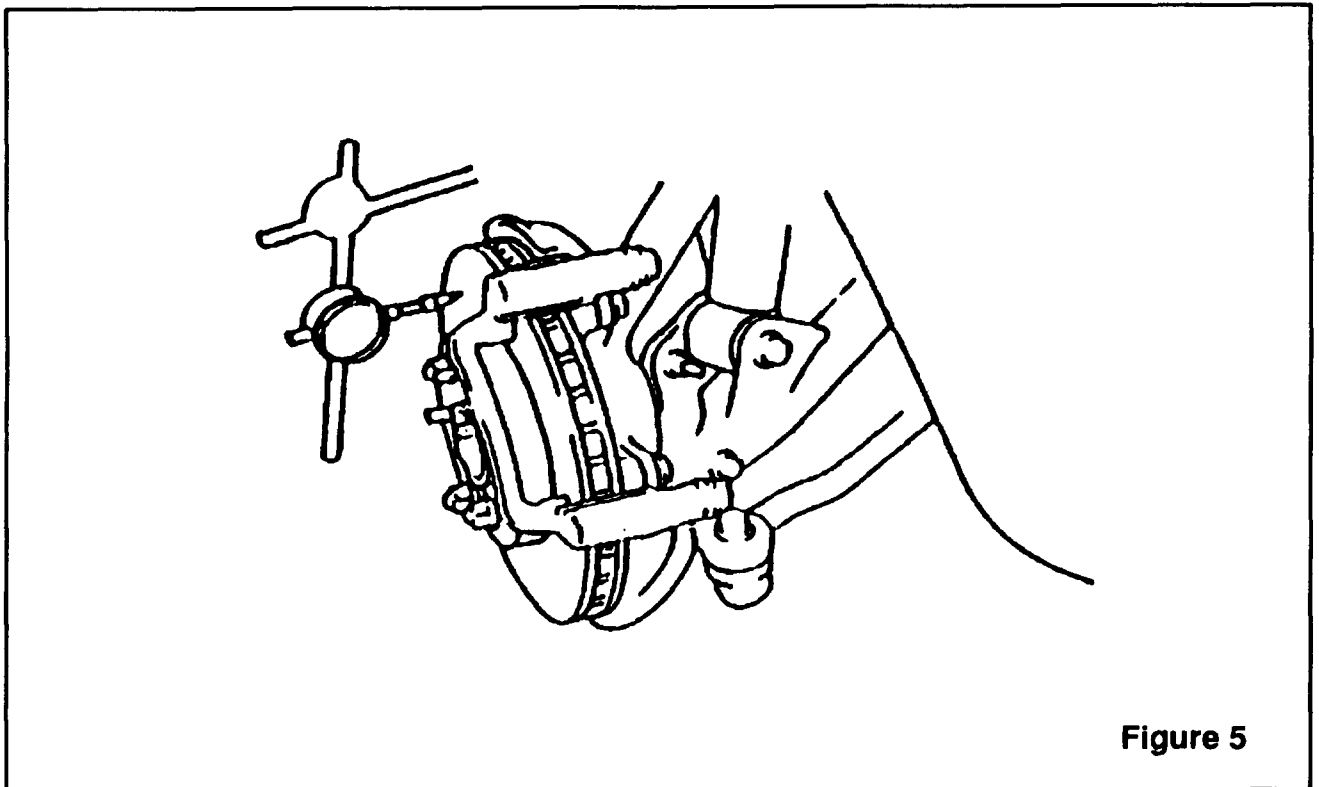
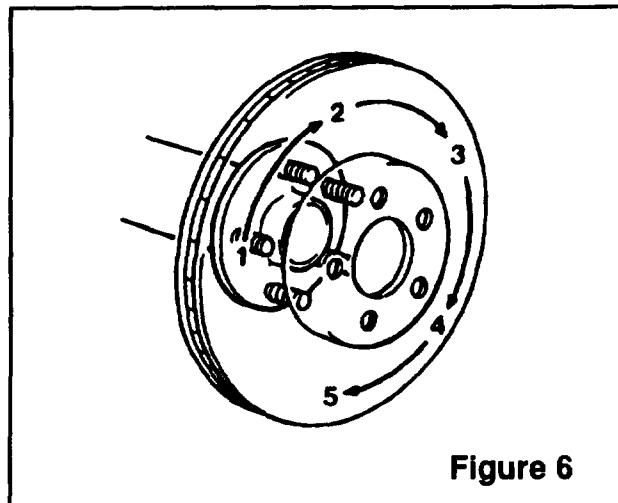

Figure 5

C. Phase Match Rotor To Hub

- If rotor run-out is at the maximum value or greater, (refer to appropriate repair manual) index the rotor one lug and measure the run-out again. Repeat this process, moving the rotor one lug each time, until the position is found where the run-out is at the minimum and within the maximum value listed in the appropriate repair manual (see Figure 6 below).



- Tighten lug nuts to the specified torque following a star sequence when installing wheel (see Figure 7 below).

Note: DO NOT USE AIR IMPACT WRENCH.

