

## SUSPENSION - REAR

1996 Toyota Supra

1995-96 SUSPENSION  
Rear

Supra

### DESCRIPTION

Rear suspension is independent, with strut assemblies, upper and lower control arms, stabilizer bar, and strut rods. See Fig. 1.

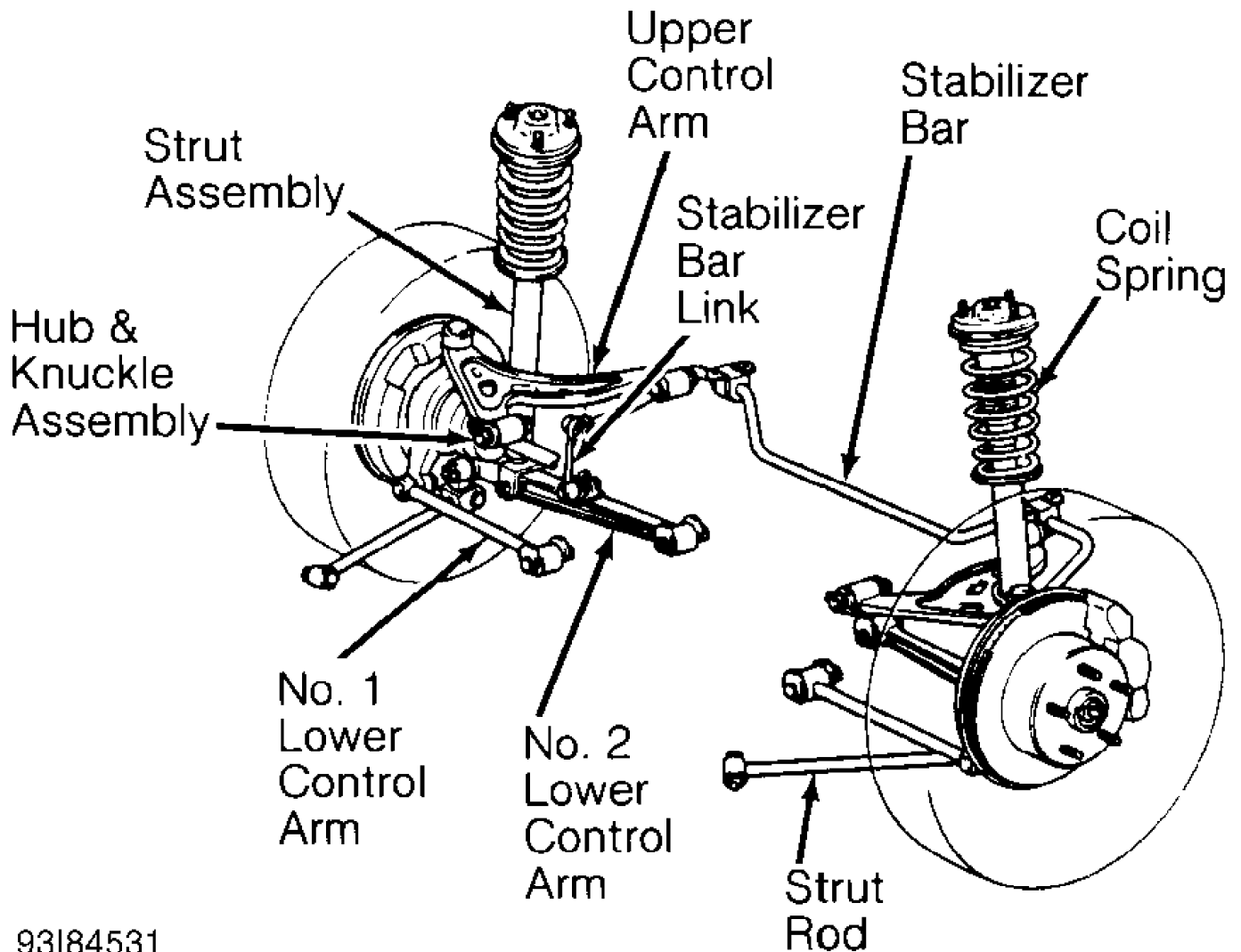

93184531

Fig. 1: Identifying Rear Suspension Components  
Courtesy of Toyota Motor Sales, U.S.A., Inc.

### ADJUSTMENTS & INSPECTION

#### WHEEL ALIGNMENT SPECIFICATIONS & PROCEDURES

NOTE: See WHEEL ALIGNMENT SPECIFICATIONS & PROCEDURES article in WHEEL ALIGNMENT section.

## WHEEL BEARING & HUB

1) Raise and support vehicle. Remove rear wheel. Remove brake caliper, leaving hose attached, and secure it out of work area. Mark brake rotor and hub for reassembly reference. Remove brake rotor.

2) Mount dial indicator on backing plate with indicator stem near center of hub. Move hub inward and outward. Observe dial indicator. Replace wheel bearing if axial play exceeds .002" (.05 mm).

3) Reposition dial indicator with stem on outer edge of hub, near outer edge of wheel stud. Rotate hub through a complete revolution while observing dial indicator. If axial runout exceeds .0028" (.07 mm), replace hub.

4) Reinstall components. Tighten bolts and wheel lug nuts to specification. See TORQUE SPECIFICATIONS. Align reference marks on brake rotor and hub.

## BALL JOINT CHECKING

1) Measure ball joint rotating torque. Separate ball joint from knuckle. Move ball joint stud back and forth 5 times. Install nut onto ball joint stud.

2) Using INCH-lb. torque wrench, rotate ball joint stud continuously one revolution per 2-4 seconds while observing torque wrench. Replace ball joint and control arm as an assembly if rotating torque is not 9-30 INCH lbs. (1.0-3.4 N.m).

## REMOVAL & INSTALLATION

### HUB & KNUCKLE ASSEMBLY

#### Removal

1) Raise and support vehicle. Remove rear wheel. Remove cotter pin and retainer lock cap from rear axle shaft nut. See Fig. 2. Apply brakes. Remove rear axle shaft nut. Release brakes.

2) Remove brake caliper, leaving hose attached, and secure it out of work area. Mark brake rotor and hub for reassembly reference. Remove brake rotor.

3) Remove exhaust pipe support rings. Lower exhaust pipe and support it with wire. Remove bolts and lower suspension arm brace. Mark flanges on rear axle shaft and differential for reassembly reference.

4) Disconnect rear axle shaft from flange at differential. DO NOT allow joint on rear axle shaft to bend excessively.

5) Using brass drift, tap rear axle shaft from hub and knuckle. Remove rear axle shaft. Use care not to damage axle shaft boots, speed sensor rotor, or oil seals when removing rear axle shaft.

6) Remove parking brake assembly. Remove Anti-Lock Brake System (ABS) speed sensor. Remove parking brake cable bolts.

7) Remove bolts from front of backing plate. Remove 14-mm hex bolt, located just above rear axle shaft area on knuckle. Move backing plate outward. Disconnect parking brake cable.

8) Remove strut rod. Remove parking brake cable bracket from No. 1 lower control arm. Mark adjuster cam on No. 1 lower control arm and subframe for reassembly reference. Adjuster cam is located on subframe side of No. 1 lower control arm.

9) Remove nut and adjuster cam from subframe and No. 1 lower control arm. Remove strut-to-No. 2 lower control arm bolt/nut. Separate strut from No. 2 lower control arm.

10) Disconnect stabilizer bar link from No. 2 lower control arm. Loosen lower ball joint nut on No. 2 lower control arm at knuckle.

11) Using Puller (SST 09610-20012), press lower ball joint from knuckle. Remove puller and nut from lower ball joint.

12) Remove nut from ball joint on upper control arm. Using Puller (SST 09628-62011), separate upper ball joint from knuckle. Remove hub, knuckle, and No. 1 lower control arm together as an assembly.

13) Remove No. 1 control arm-to-knuckle nut. Using Puller (SST 09610-20012), press stud from knuckle. Separate No. 1 lower control arm from knuckle.

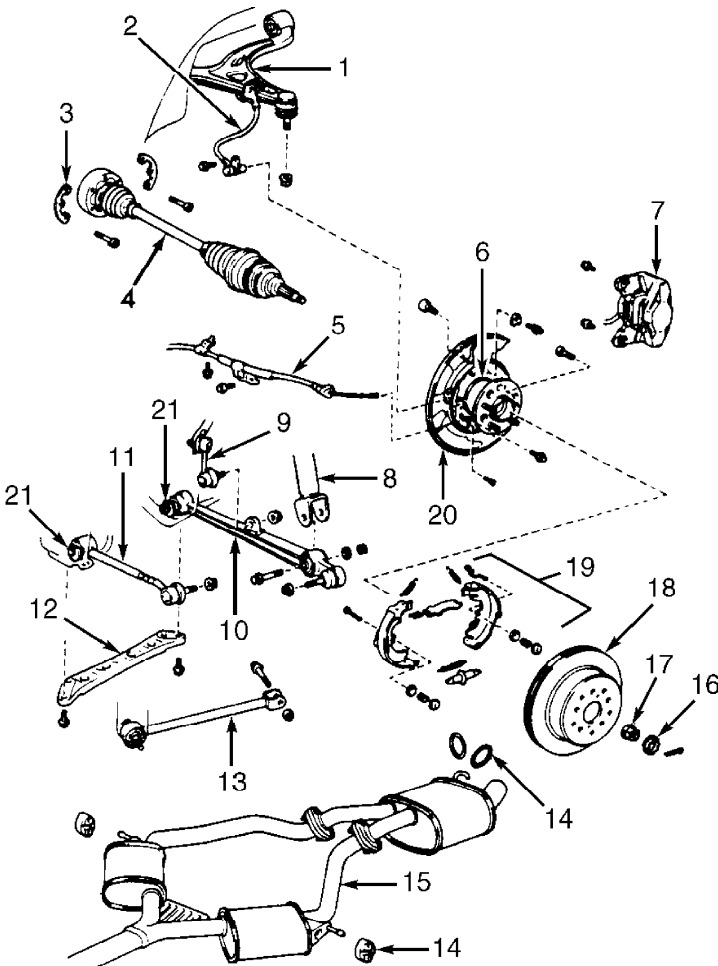

- |                             |                                |
|-----------------------------|--------------------------------|
| 1. Upper Control Arm        | 11. No. 1 Lower Control Arm    |
| 2. ABS Speed Sensor         | 12. Lower Suspension Arm Brace |
| 3. Lock Plate               | 13. Strut Rod                  |
| 4. Rear Axle Shaft          | 14. Exhaust Pipe Support Ring  |
| 5. Parking Brake Cable      | 15. Exhaust Pipe Assembly      |
| 6. Hub & Knuckle Assembly   | 16. Retainer Lock Cap          |
| 7. Brake Caliper            | 17. Rear Axle Shaft Nut        |
| 8. Strut Assembly           | 18. Brake Rotor                |
| 9. Stabilizer Bar Link      | 19. Parking Brake Assembly     |
| 10. No. 2 Lower Control Arm | 20. Backing Plate              |
|                             | 21. Adjusting Cam              |

93J84532

Fig. 2: Removing Hub & Knuckle  
Courtesy of Toyota Motor Sales, U.S.A., Inc.

#### Installation

- 1) Install hub and knuckle onto upper and No. 2 lower control

arms. Install and tighten NEW ball joint nuts to specification. See TORQUE SPECIFICATIONS.

2) Loosely install strut-to-No. 2 lower control arm bolt/nut. Install stabilizer bar link onto No. 2 lower control arm. Tighten nut to specification.

3) Install No. 1 lower control arm. Install adjuster cam with reference marks aligned. Loosely install adjuster cam nut.

4) Install No. 1 lower control arm onto knuckle with NEW nut. Tighten No. 1 lower control arm-to-knuckle nut to specification. Install strut rod, leaving bolts/nuts loose.

5) Install parking brake cable through backing plate. Move backing plate inward. Install and tighten 14-mm hex bolt to 132 ft. lbs. (179 N.m). Install and tighten backing plate bolts.

6) Apply high temperature grease to parking brake shoe contact areas before installation. Install parking brake. Install brake rotor. Temporarily install wheel lug nuts.

7) Remove adjuster hole cover from rear of backing plate to gain access to parking brake adjuster wheel. Rotate adjuster wheel to expand parking brake shoes until brake rotor will not rotate.

8) Rotate adjuster wheel in opposite direction 8 notches. Verify brake rotor rotates. Install hole cover. Remove wheel lug nuts and brake rotor.

9) Clean tip of ABS speed sensor. Install ABS speed sensor. Tighten bolt to specification. See TORQUE SPECIFICATIONS. Install rear axle shaft. Use care not to damage boots, speed sensor rotor, or oil seals when installing rear axle shaft.

10) Align reference marks on axle shaft and differential flanges. Apply engine oil to flange bolt threads. Install lock plates and flange bolts. Tighten bolts to specification.

11) Install and tighten lower suspension arm brace bolts to specification. Install brake rotor. Align marks on brake rotor and hub. Install brake caliper. Tighten bolts to specification.

12) Install rear axle shaft nut. Apply brakes. Tighten nut to specification. Release brakes. Install retainer lock cap and cotter pin.

13) Install rear wheel. Tighten wheel lug nuts to specification. Lower vehicle. Bounce vehicle several times to settle suspension. Raise vehicle with floor jack placed under differential. Remove rear wheel.

14) Align reference marks on adjuster cam and subframe. Tighten adjuster cam nut, strut rod bolts/nuts, and strut-to-No. 2 lower control arm bolts/nuts.

15) Install the parking brake cable bracket. Install the rear wheel and the exhaust pipe. Check rear wheel alignment. Refer to the WHEEL ALIGNMENT SPECIFICATIONS & PROCEDURES article in WHEEL ALIGNMENT section.

## LOWER CONTROL ARMS, STRUT ROD & BALL JOINT

**NOTE:** Manufacturer recommends rear axle shaft removal when removing lower control arms.

### Removal

1) Raise and support vehicle. Remove rear wheel. Remove cotter pin and retainer lock cap from rear axle shaft nut. See Fig. 2. Apply brakes. Remove rear axle shaft nut. Release brakes.

2) Remove brake caliper, leaving hose attached, and secure it out of work area. Remove exhaust pipe support rings. Lower exhaust pipe and support it with wire. Remove lower suspension arm brace. See Fig. 2. Mark flanges on axle shaft flange and differential for reassembly reference.

3) Disconnect rear axle shaft from differential. DO NOT allow joint on rear axle shaft to bend excessively.

4) Using brass drift, tap rear axle shaft from hub and knuckle. Remove rear axle shaft. Use care not to damage axle shaft boots, speed sensor rotor, or oil seals when removing rear axle shaft.

5) Remove strut rod. See Fig. 2. Disconnect parking brake cable bracket from No. 1 lower control arm. Remove No. 1 lower control arm-to-knuckle nut. Using Puller (SST 09610-20012), press out stud from No. 1 lower control arm.

6) Mark adjuster cam on No. 1 lower control arm and subframe for reassembly reference. Adjuster cam is located on subframe side of No. 1 lower control arm.

7) Remove nut and adjuster cam from subframe and No. 1 lower control arm. Remove No. 1 lower control arm. Remove strut-to-No. 2 lower control arm bolt/nut. Separate strut from No. 2 lower control arm.

8) Disconnect stabilizer bar link from No. 2 lower control arm. See Fig. 2. Loosen lower ball joint nut on No. 2 lower control arm at knuckle. Using Puller (SST 09610-20012), press out lower ball joint.

9) Remove nut and adjuster cam from subframe and No. 2 lower control arm. Remove No. 2 lower control arm. Measure ball joint rotating torque. See BALL JOINT CHECKING under ADJUSTMENTS & INSPECTION.

#### Installation

1) Install No. 2 lower control arm onto knuckle. Install and tighten NEW lower ball joint retaining nut to specification. Refer to the TORQUE SPECIFICATIONS.

2) Install No. 2 lower control arm onto subframe. Install adjuster cam with reference marks aligned. Install adjuster cam nut loosely.

3) Loosely install strut-to-No. 2 lower control arm bolt/nut. Install stabilizer bar link on No. 2 lower control arm. Install and tighten nut to specification.

4) Install No. 1 lower control arm onto knuckle. Install and tighten NEW nut onto stud of No. 1 lower control arm at knuckle.

5) Install No. 1 lower control arm onto subframe. Install adjuster cam with reference marks aligned. Loosely install adjuster cam nut.

6) Install strut rod, leaving bolts/nuts loose. Install brake caliper. Tighten bolts to specification. Install rear axle shaft. Use care not to damage axle shaft boots, speed sensor rotor, or oil seals.

7) Align reference marks on flanges. Apply engine oil to flange bolt threads. Install lock plates and flange bolts. Tighten flange bolts to specification.

8) Install lower suspension arm brace. Tighten bolts to specification. Install brake caliper. See TORQUE SPECIFICATIONS.

9) Install rear axle shaft nut. Apply brakes and tighten nut to specification. Release brakes. Install retainer lock cap and cotter pin.

10) Install rear wheel. Tighten wheel lug nuts to specification. See TORQUE SPECIFICATIONS. Lower vehicle. Bounce vehicle several times to settle suspension. Raise vehicle with floor jack placed under differential. Remove rear wheel.

11) Ensure reference marks on all adjuster cams and subframe are aligned. Tighten adjuster cam nuts, strut rod bolts/nuts, and strut-to-No. 2 lower control arm bolts/nuts to specification.

12) Install the parking brake cable bracket. Install the rear wheel and the exhaust pipe. Check rear wheel alignment. Refer to the WHEEL ALIGNMENT SPECIFICATIONS & PROCEDURES article in WHEEL ALIGNMENT section.

## LOWER CONTROL ARM BUSHINGS

Lower control arm bushing replacement information is not available from manufacturer.

## STABILIZER BAR

### Removal

1) Raise and support vehicle. Remove exhaust pipe support rings. Lower exhaust pipe and support it with wire. Remove lower suspension arm brace. See Fig. 2.

2) Remove stabilizer bar links. Remove stabilizer bar brackets and stabilizer bar. Remove brackets and insulators from stabilizer bar if necessary.

### Inspection

1) Move ball joint stud on stabilizer bar link back and forth 5 times. Install nut onto ball joint stud.

2) Using INCH-lb. torque wrench, rotate ball joint stud continuously one revolution per 2-4 seconds while observing rotating torque. Replace stabilizer bar link if rotating torque is not 4.4-8.8 INCH lbs. (0.5-1.0 N.m).

### Installation

To install, reverse removal procedure. Install insulators onto stabilizer bar at outside of bushing stopper. Tighten bolt/nuts to specification. See TORQUE SPECIFICATIONS.

## STRUT ASSEMBLY

### Removal

1) Remove necessary interior panels for access to strut nuts. Raise and support vehicle. Remove rear wheel. Remove brake caliper, leaving hose attached, and secure it out of work area.

2) Disconnect stabilizer bar link from No. 2 lower control arm. See Fig. 2. Remove strut-to-No. 2 lower control arm bolt/nut. Remove wheel housing inner cover and strut cap. See Fig. 3.

3) If strut is to be disassembled, loosen, but DO NOT remove shaft nut. Remove strut-to-body nuts. Remove strut assembly.

### Disassembly & Inspection

1) Install bolt into lower bolt area of strut assembly. Mount strut assembly in a vise by securing the bolt in the vise. Using Coil Spring Compressor (SST 09727-30020), compress coil spring.

2) Remove shaft nut. Remove suspension support, coil spring, and insulator. Separate insulator and spring bumper from suspension support. See Fig. 3. Check strut assembly operation by pushing inward and pulling outward on strut shaft. Shaft should move smoothly, with no abnormal resistance or noise.

3) If discarding strut assembly, release gas pressure. Fully extend shaft. Drill hole into strut housing 1.2" (30 mm) from bottom, just above lower retaining bolt hole.

CAUTION: Use care when drilling hole, as strut is filled with gas.

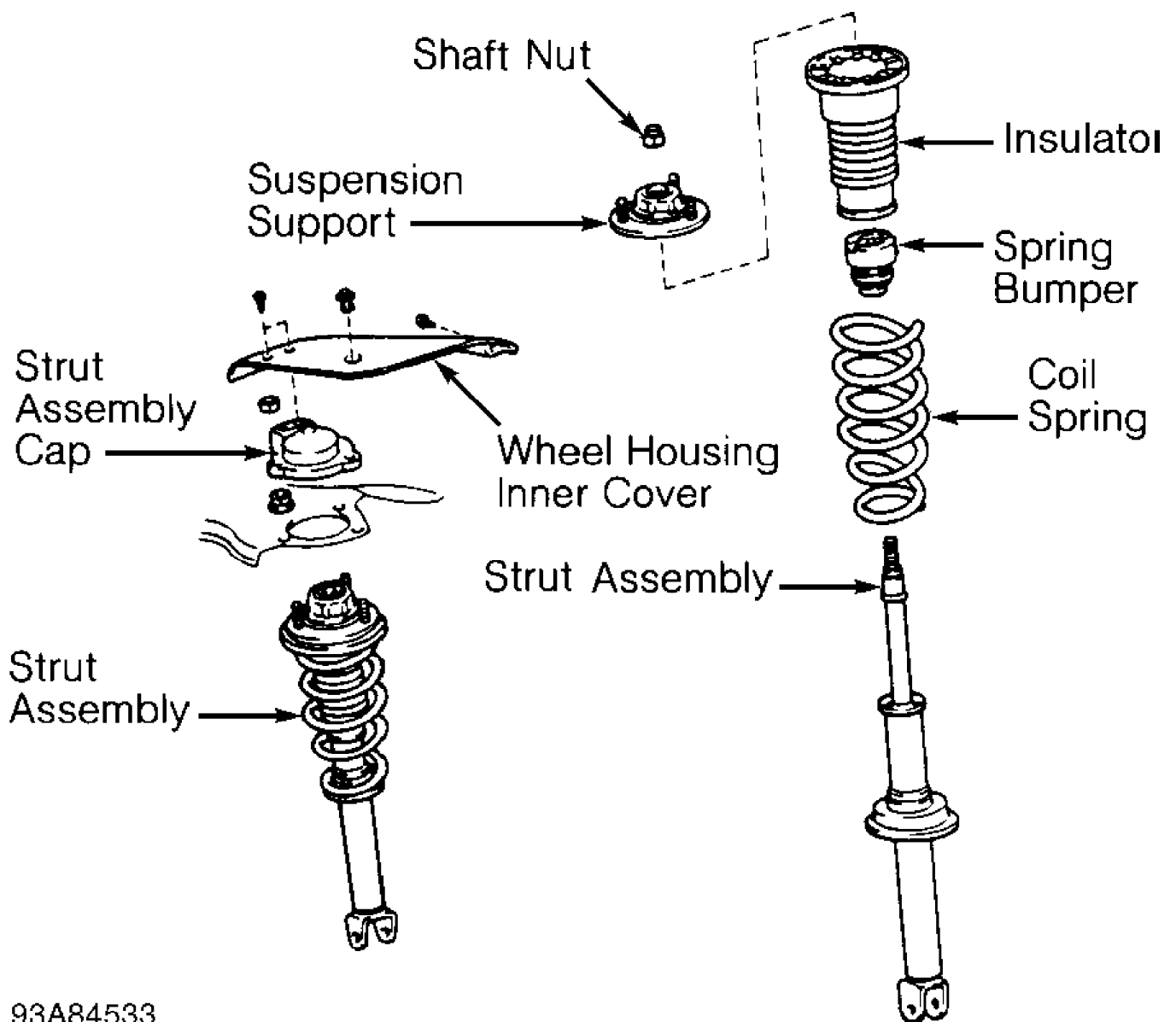

### 93A84533

Fig. 3: Exploded View Of Strut Assembly  
 Courtesy of Toyota Motor Sales, U.S.A., Inc.

#### Reassembly

1) To reassemble, reverse disassembly procedure. When installing suspension support onto insulator, engage notch on insulator with bolt head on bottom of suspension support. When installing coil spring, engage bottom of coil spring with appropriate area of spring seat on strut.

2) Install NEW shaft nut, leaving it loose. Before releasing coil spring compressor, rotate suspension support so bolt aligns with bolt mounting hole on lower end of strut. See Fig. 4. Release spring compressor. Ensure bolt aligns with lower end of strut.

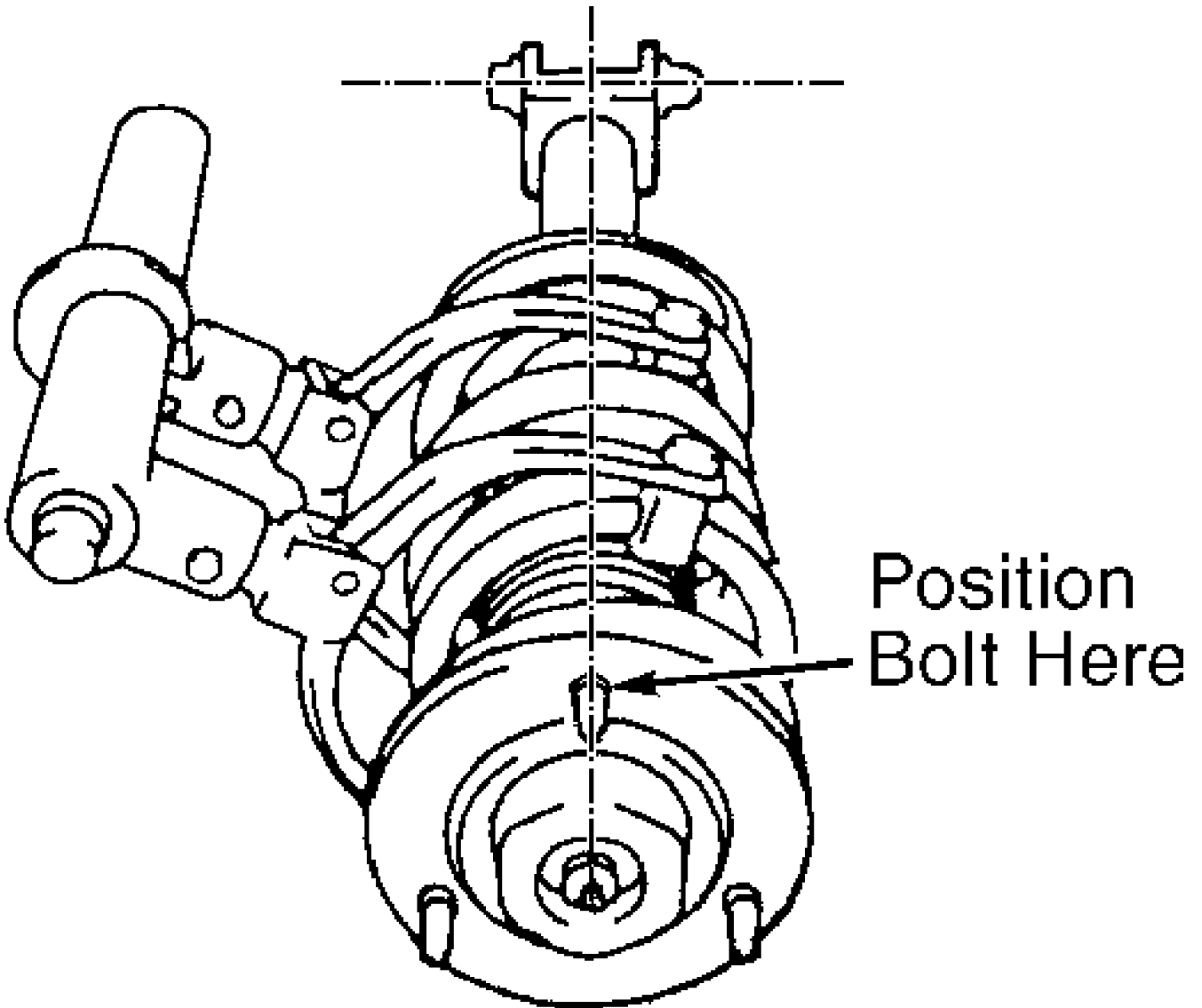

## 93B84534

Fig. 4: Aligning Suspension Support  
Courtesy of Toyota Motor Sales, U.S.A., Inc.

### Installation

1) Install strut. Install and tighten strut-to-body nuts to specification. Tighten the shaft nut to specification. Refer to the TORQUE SPECIFICATIONS.

2) To install remaining components, reverse removal procedure. Tighten bolts/nuts and wheel lug nuts to specification. Check rear wheel alignment. See WHEEL ALIGNMENT SPECIFICATIONS & PROCEDURES article in WHEEL ALIGNMENT section.

### UPPER CONTROL ARM & BALL JOINT

NOTE: Manufacturer recommends rear axle shaft removal when removing lower control arms.

#### Removal

1) Raise and support vehicle. Remove rear wheel. Remove cotter pin and retainer lock cap from rear axle shaft nut. See Fig. 2. Apply brakes. Remove rear axle shaft nut. Release brakes.

2) Remove brake caliper, leaving hose attached, and secure it out of work area. Remove exhaust pipe support rings. Lower exhaust pipe and support it with wire. Remove lower suspension arm brace. Mark flanges on axle shaft and differential for reassembly reference.

3) Disconnect rear axle shaft from differential. DO NOT allow joint on rear axle shaft to bend excessively. Using brass drift, tap rear axle shaft from hub. Remove rear axle shaft. Use care not to damage axle shaft boots, speed sensor rotor, or oil seals when removing rear axle shaft.

4) Remove Anti-Lock Brake System (ABS) speed sensor. Disengage wiring for ABS speed sensor from upper control arm. Remove nut from upper ball joint on upper control arm. Using Puller (SST 09628-62011), separate upper ball joint from knuckle.

5) Remove upper control arm-to-subframe bolts/nuts and upper control arm. Measure ball joint rotating torque. See BALL JOINT CHECKING under ADJUSTMENTS & INSPECTION.

#### Installation

1) If replacing nut for front bolt on upper control arm, install nut and retainer into washer before installation. See Fig. 5. Install upper control arm onto subframe. Install upper control arm-to-subframe bolts/nuts, with tips of lock nuts downward. Leave bolt/nuts at this time.

2) Install upper ball joint into knuckle. Install and tighten NEW nut to specification. See TORQUE SPECIFICATIONS. Clean tip of speed sensor. Install speed sensor. Install rear axle shaft. Use care not to damage boots, speed sensor rotor, or oil seals when installing axle shaft.

3) Align reference marks on rear axle shaft and differential flanges. Apply engine oil to threads of flange bolts. Install lock plates and flange bolts. Tighten flange bolts to specification.

4) Install lower suspension arm brace. Tighten bolts to specification. Install brake caliper. Tighten bolts to specification.

5) Install rear axle shaft nut. Apply brakes. Tighten rear axle shaft nut to specification. Release brakes. Install retainer lock cap and cotter pin.

6) Install rear wheel. Tighten wheel lug nuts to specification. Lower vehicle. Bounce vehicle several times to settle suspension. Raise vehicle with floor jack placed under differential. Remove rear wheel.

7) Tighten upper control arm-to-subframe bolts/nuts to specification. Install rear wheel and exhaust pipe. Check rear wheel alignment. See WHEEL ALIGNMENT SPECIFICATIONS & PROCEDURES article in WHEEL ALIGNMENT section.

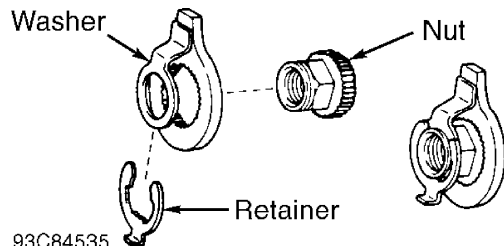

93C84535

Fig. 5: Installing Nut & Retainer In Washer  
Courtesy of Toyota Motor Sales, U.S.A., Inc.

## UPPER CONTROL ARM BUSHINGS

Upper control arm bushing replacement information is not available from manufacturer.

## WHEEL BEARING

### Removal

1) Remove the wheel hub and knuckle assembly. Refer to the HUB & KNUCKLE ASSEMBLY procedures under REMOVAL & INSTALLATION. Clamp knuckle in a soft-jawed vise.

2) Remove dust deflector. See Fig. 6. Using Puller (SST 09520-00031), remove hub from knuckle. Remove backing plate.

3) Using Bearing Remover (SST 09950-00020), Handle (SST 09608-00020), and Adapter (SST 09608-00080), press bearing race from hub. Using Puller (SST 09308-00010), remove oil seals. Remove snap ring from rear of knuckle.

4) Position inner race onto wheel bearing. Using Adapter (SST 09608-00060), press wheel bearing from knuckle.

### Installation

1) Using Adapters (SST 09527-17011) and (SST 09608-32010), press NEW wheel bearing into knuckle. Install snap ring. Install bearing race.

2) Using Oil Seal Installer (SST 09608-32010), tap NEW outer oil seal into knuckle until oil seal is even with surface of knuckle. Apply grease to oil seal lip.

3) Install backing plate. Install bearing race into knuckle. Using Adapter (SST 09608-00060), press hub into knuckle.

4) Using Oil Seal Installer (SST 09223-15020), tap NEW inner oil seal into knuckle until oil seal is even with surface of knuckle. Apply grease to seal lip on oil seal.

5) Position NEW dust deflector so hole in dust deflector aligns with hole for speed sensor. Using Adapter (SST 09608-06160), press on NEW dust deflector. Install hub and knuckle assembly.

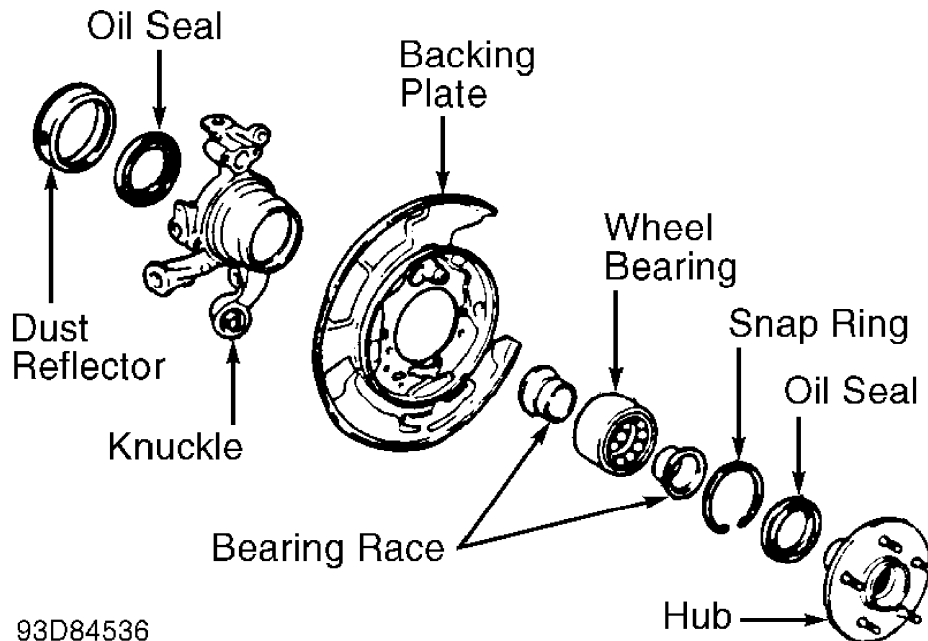

93D84536

Fig. 6: Identifying Knuckle Components  
Courtesy of Toyota Motor Sales, U.S.A., Inc.

## TORQUE SPECIFICATIONS

TORQUE SPECIFICATIONS

Application	Ft. Lbs. (N.m)
Adjuster Cam Nut	136 (184)
Backing Plate-To-Knuckle Bolt	19 (26)
Ball Joint Nut	
Lower Ball Joint	110 (149)
Upper Ball Joint	80 (109)
Brake Caliper Bolt	77 (104)
Lower Suspension Arm Brace Bolt	13 (18)
No. 1 Lower Control Arm-To-Knuckle Nut	43 (58)
Rear Axle Shaft Flange Bolt	61 (83)
Rear Axle Shaft Nut	213 (289)
Shaft Nut	20 (27)
Stabilizer Bar Bracket Bolt/Nut	23 (31)
Stabilizer Bar Link Nut	54 (73)
Strut Assembly-To-Body Nut	19 (26)
Strut Assembly-To-No. 2 Lower Control Arm Bolt/Nut	101 (137)
Strut Rod Bolt/Nut	136 (184)
Upper Control Arm-To-Subframe Bolt/Nut	121 (164)
Wheel Lug Nut	76 (103)
	INCH Lbs. (N.m)
ABS Speed Sensor Bolt	71 (8.0)
Dust Cover Bolt	71 (8.0)
Parking Brake Cable-To-Backing Plate Bolt	71 (8.0)
Strut Assembly Cap Nut	89 (10.0)