

SUSPENSION - FRONT

1996 Toyota Supra

1995-96 SUSPENSION
Front

Supra

DESCRIPTION

The independent strut-type front suspension consists of vertically mounted strut assemblies, upper and lower control arms, and stabilizer bar. See Fig. 1.

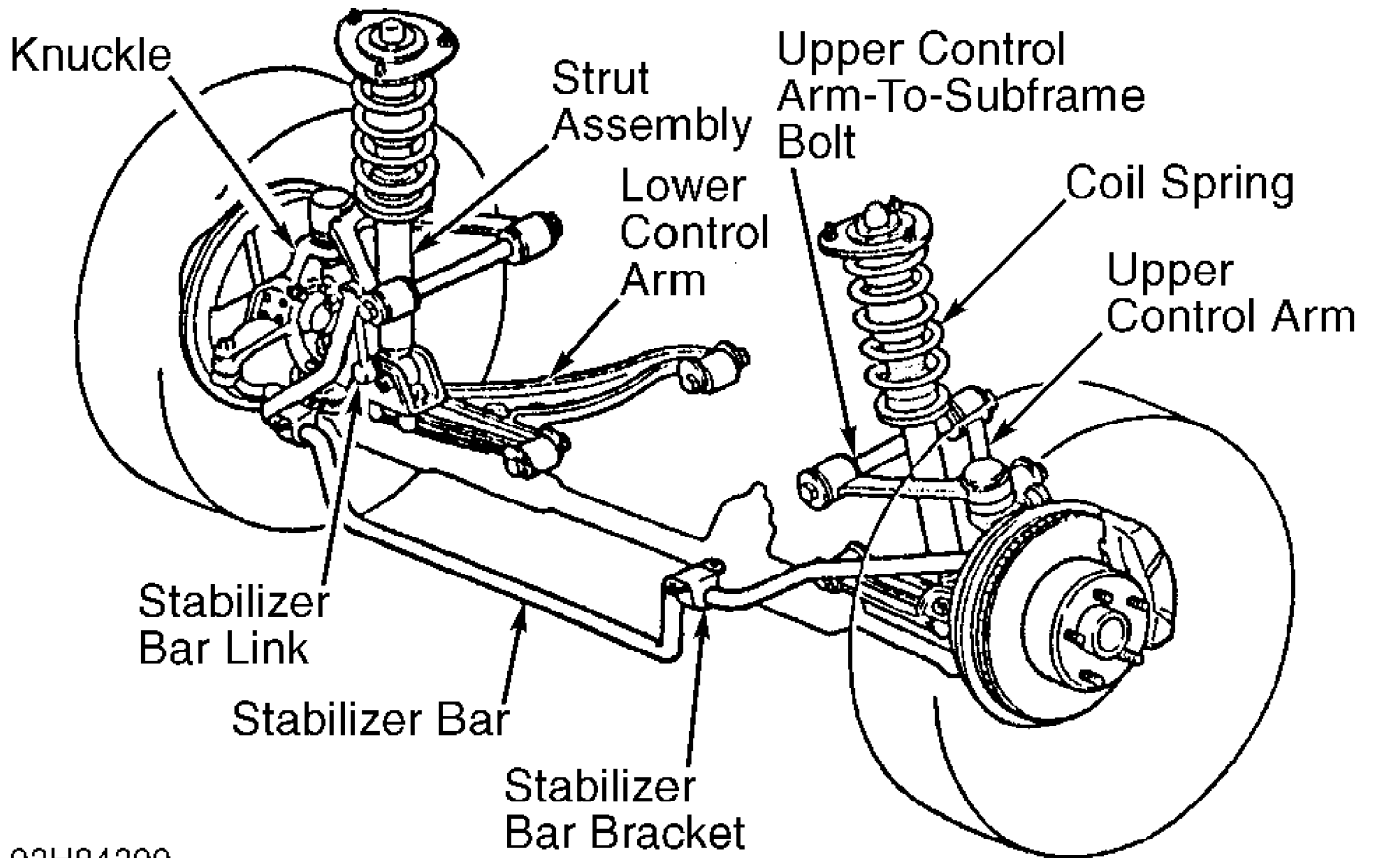

93H84399

Fig. 1: Identifying Front Suspension Components
Courtesy of Toyota Motor Sales, U.S.A., Inc.

ADJUSTMENTS & INSPECTION

WHEEL ALIGNMENT SPECIFICATIONS & PROCEDURES

NOTE: See WHEEL ALIGNMENT SPECIFICATIONS & PROCEDURES article in WHEEL ALIGNMENT section.

WHEEL BEARING & HUB

1) Raise and support vehicle. Remove front wheel. Remove brake caliper, leaving hose attached, and secure it out of work area. Mark brake rotor and hub for reassembly reference.

2) Remove brake rotor. Mount dial indicator on dust shield with indicator stem near center of hub. Move hub inward and outward while observing dial indicator. Replace wheel bearing if axial play exceeds 0.002" (0.05 mm).

3) Reposition dial indicator with indicator stem on outer edge of hub, near outer edge of wheel stud. Rotate hub through a full revolution while observing dial indicator. If axial runout exceeds 0.002" (0.05 mm), replace hub.

4) Reinstall components. Align reference marks on brake rotor and hub. Tighten bolts and wheel lug nuts to specification. See TORQUE SPECIFICATIONS.

BALL JOINT CHECKING

1) Inspect ball joint for vertical play. Raise and support vehicle. Set front wheels to straight-ahead position. Press brake pedal.

2) Using floor jack, raise lower control arm until there is about 1/2 load on the coil spring. Pry front wheel up and down. Inspect for vertical movement in ball joint. Replace control arm and ball joint as an assembly if vertical movement exceeds 0.012" (0.30 mm).

3) To measure ball joint rotating torque, separate ball joint from knuckle. Move ball joint stud back and forth 5 times. Install nut onto ball joint stud.

4) Using INCH-lb. torque wrench, rotate ball joint stud continuously one revolution per 2-4 seconds and note rotating torque. Replace ball joint and control arm as an assembly if rotating torque is not 9-30 INCH lbs. (1.0-3.4 N.m).

REMOVAL & INSTALLATION

HUB & KNUCKLE ASSEMBLY

Removal

1) Raise and support vehicle. Remove front wheel. Remove brake caliper, leaving hose attached, and secure it out of work area. Mark brake rotor and hub for reassembly reference. Remove brake rotor.

2) Remove bolt and Anti-Lock Brake System (ABS) speed sensor from knuckle. See Fig. 2. Remove cotter pin and nut from tie rod. Separate tie rod from knuckle.

3) Remove ball joint nuts. Using Puller (SST 09268-62011), separate ball joints from knuckle. Remove hub and knuckle as an assembly.

Installation

To install, reverse removal procedure. Align reference marks on brake rotor and hub. Tighten bolts/nuts and wheel lug nuts to specification. See TORQUE SPECIFICATIONS. Check wheel alignment. See WHEEL ALIGNMENT SPECIFICATIONS & PROCEDURES article in WHEEL ALIGNMENT.

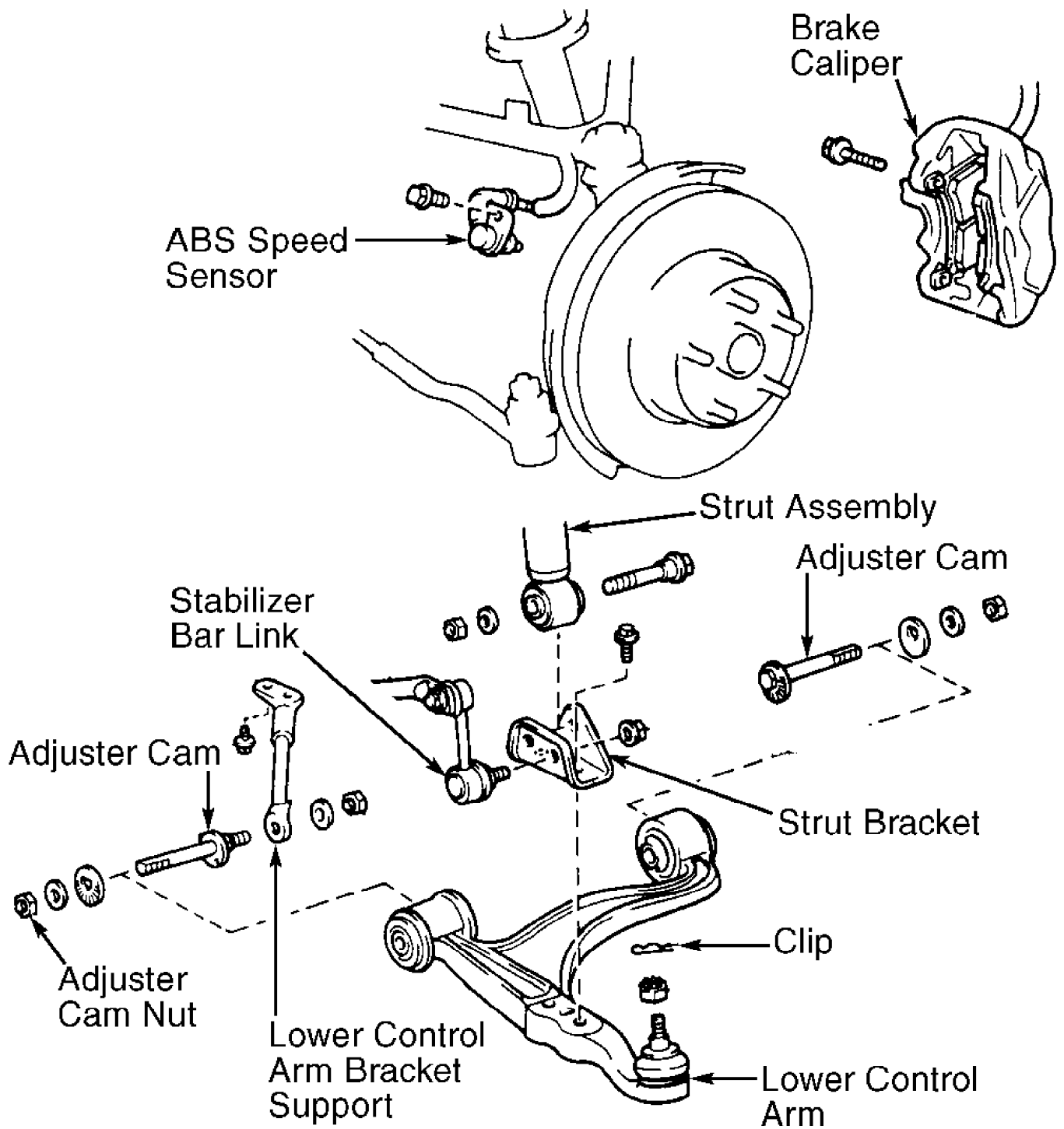

94D47756

Fig. 2: Identifying Lower Control Arm Components
 Courtesy of Toyota Motor Sales, U.S.A., Inc.

LOWER CONTROL ARM & BALL JOINT

Removal

- 1) Raise and support vehicle. Remove front wheel. Remove

lower engine cover. Remove brake caliper, leaving hose attached, and secure it out of work area.

2) Disconnect stabilizer bar link from lower control arm. See Fig. 2. Remove clip and nut from lower ball joint. Using Puller (SST 09268-62011), separate lower ball joint from knuckle.

3) Disconnect strut assembly from bracket on lower control arm bolt. Remove bolts/nuts and lower control arm bracket support.

4) Mark adjuster cams and subframe for reassembly reference. Adjuster cams are located on each end of lower control arm.

5) Remove adjuster cam nuts and adjuster cams from each end of lower control arm. Remove lower control arm. Measure ball joint rotating torque. See BALL JOINT CHECKING under ADJUSTMENTS & INSPECTION.

Installation

1) Install lower control arm, adjuster cams, and adjuster cam nuts. Align reference marks on adjuster cams and subframe. Leave adjuster cam nuts loose at this time.

2) Install and tighten lower ball joint nut to specification. See TORQUE SPECIFICATIONS. Install strut assembly onto strut assembly bracket. Install and tighten bolt to specification.

3) Install stabilizer bar link, brake caliper, and front wheel. Install and tighten bolts/nuts and wheel lug nuts to specification.

4) Lower vehicle. Bounce vehicle several times to settle suspension. Position floor jack under lower control arm. Raise vehicle. Remove front wheel.

5) Align reference marks on adjuster cams and subframe while vehicle weight is on lower control arm. Tighten adjuster cam nuts to specification.

6) Install lower control arm bracket support. Tighten bolts/nuts to specification. Install front wheel and lower engine cover. Check wheel alignment. See WHEEL ALIGNMENT SPECIFICATIONS & PROCEDURES article in WHEEL ALIGNMENT.

LOWER CONTROL ARM BUSHINGS

Lower control arm bushing replacement information is not available from manufacturer.

STABILIZER BAR

Removal

1) Raise and support vehicle. Remove front wheels. Remove lower engine cover and splash shields. Remove stabilizer bar links, located between stabilizer bar and each lower control arm. See Fig. 2.

2) Remove bolts/nuts, stabilizer bar brackets, and stabilizer bar. Remove brackets and insulators from stabilizer bar if necessary.

Inspection

1) Move ball joint stud on stabilizer bar link back and forth 5 times. Install nut onto ball joint stud on stabilizer link.

2) Using INCH-lb. torque wrench, rotate ball joint stud continuously one revolution per 2-4 seconds while measuring rotating torque. Replace stabilizer bar link if rotating torque is not 2.6-8.7 INCH lbs. (0.3-1.0 N.m).

Installation

To install, reverse removal procedure. Install insulators onto stabilizer bar at painted areas on stabilizer bar (if removed). Tighten bolt/nuts and wheel lug nuts to specification. See TORQUE SPECIFICATIONS.

STRUT ASSEMBLY

Removal

1) Raise and support vehicle. Remove front wheel. Remove brake caliper, leaving hose attached, and secure aside. Remove Anti-Lock Brake System (ABS) speed sensor from knuckle. See Fig. 2.

2) Disengage clamp for ABS speed sensor wiring from upper control arm. Remove plug from top of strut assembly. See Fig. 3. If disassembling strut, loosen, but DO NOT remove, shaft nut.

3) Remove splash shield. If removing driver's side strut, remove windshield washer fluid reservoir. On all strut assembly applications, remove upper control arm-to-subframe bolt. See Fig. 1.

4) Separate upper control arm from subframe. Use wire to support upper control arm and knuckle. Disconnect stabilizer bar link from lower control arm. Stabilizer bar link is located between stabilizer bar and lower control arm.

5) Disconnect strut from bracket on lower control arm. See Fig. 2. Remove strut-to-body nuts and reinforcement from strut tower. See Fig. 3. Remove strut.

Disassembly & Inspection

1) Install bolt into lower bolt area of strut. Mount strut assembly in a vise by securing the bolt in the vise. Using Coil Spring Compressor (SST 09727-30020), compress coil spring.

2) Remove shaft nut and strut components. See Fig. 3. Check strut operation by pushing inward and pulling outward on the strut shaft. Shaft should move smoothly, with no abnormal resistance or noise.

3) If discarding strut, release internal pressure. Fully extend shaft. Drill hole in strut housing 1.2" (30 mm) from bottom of housing, just above lower retaining bolt bushing.

CAUTION: Use care when drilling hole, as strut is filled with gas under pressure.

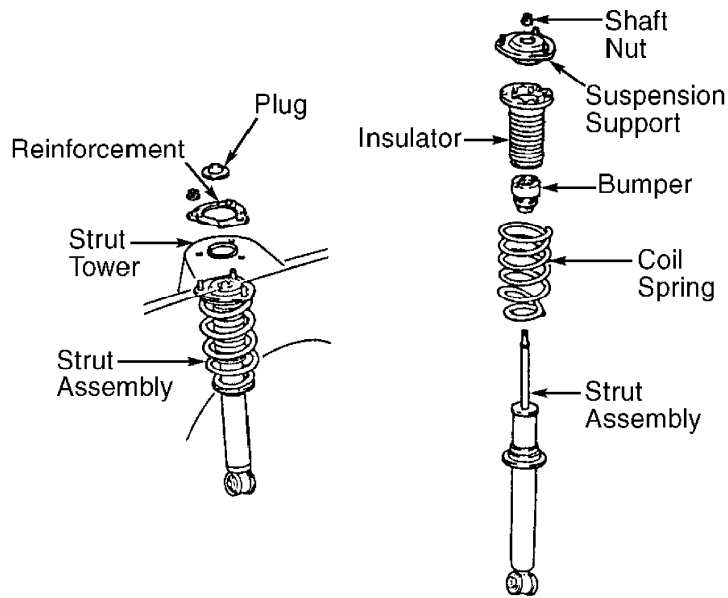

93B84401

Fig. 3: Identifying Strut Components
Courtesy of Toyota Motor Sales, U.S.A., Inc.

Reassembly

1) To reassemble, reverse disassembly procedure. When

installing suspension support onto insulator, engage notch on insulator with bolt head on bottom of suspension support. When installing coil spring, engage bottom of coil spring with proper area of spring seat on strut assembly.

2) Install NEW shaft nut, leaving it loose at this time.

Shaft nut will be tightened to specification after strut is installed.

3) Before releasing coil spring compressor, rotate suspension support so bolt aligns with bolt mounting hole on lower end of strut. See Fig. 4. Release spring compressor. Ensure bolt is aligned with lower end of strut.

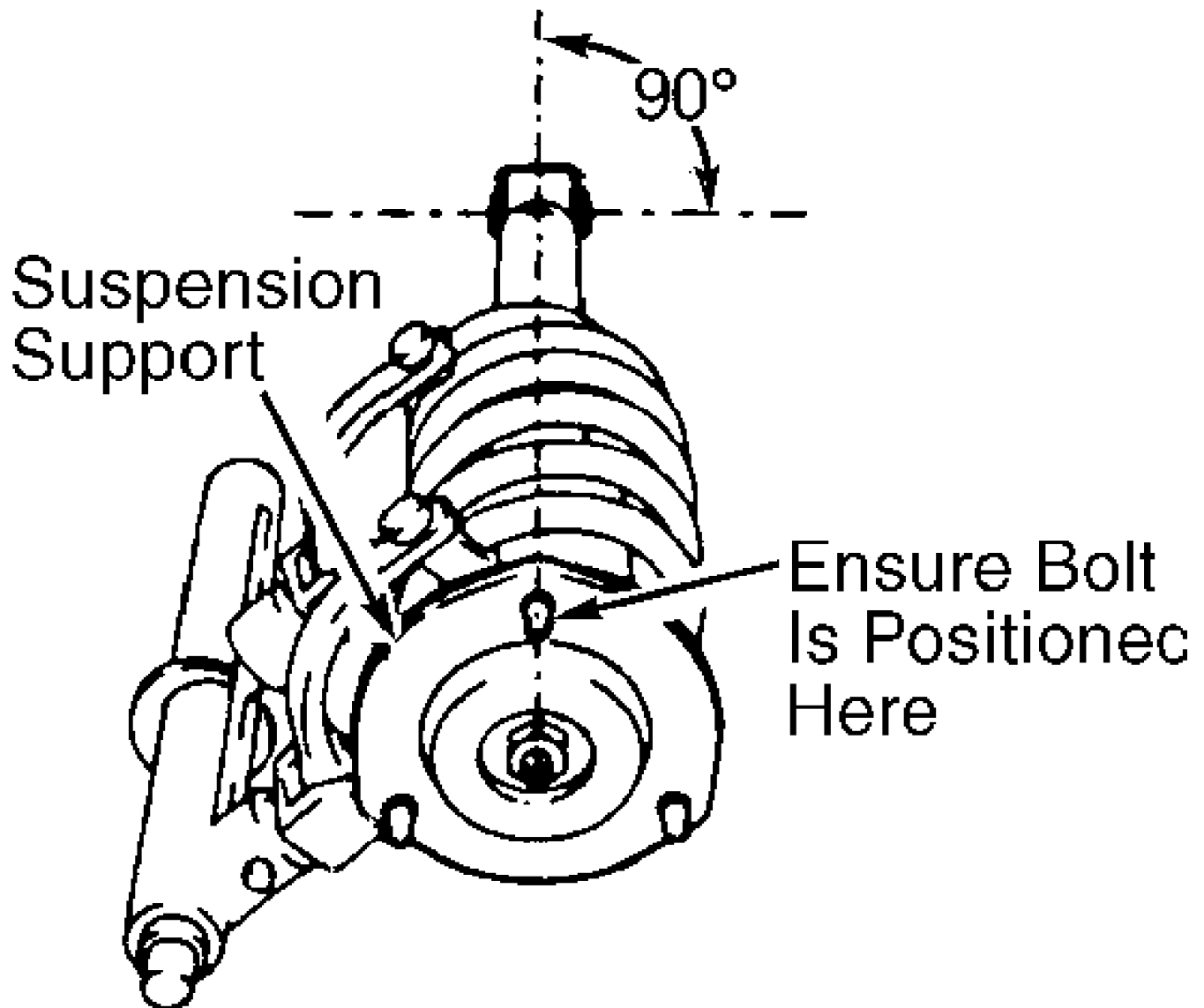

93C84402

Fig. 4: Aligning Suspension Support & Strut
Courtesy of Toyota Motor Sales, U.S.A., Inc.

Installation

1) Install strut assembly and reinforcement. Install and tighten strut nuts to specification. See TORQUE SPECIFICATIONS.

Install plug.

2) Tighten shaft nut to specification. Install strut assembly-to-strut bracket bolt, leaving it loose at this time. Install stabilizer bar link onto lower control arm. Tighten nut to specification.

3) Install upper control arm-to-subframe bolt with bolt head toward front of vehicle, leaving it loose at this time. Install splash shield and windshield washer fluid reservoir (if removed).

4) Install clamp for ABS speed sensor wiring. Install ABS speed sensor, brake caliper, and front wheel. Tighten bolts and wheel lug nuts to specification.

5) Lower vehicle. Bounce vehicle several times to settle suspension. Position floor jack under lower control arm. Raise vehicle. Remove front wheel.

6) Tighten strut assembly-to-strut bracket bolt and upper control arm bolt to specification with vehicle weight on lower control arm. Install front wheel. Check wheel alignment. See WHEEL ALIGNMENT SPECIFICATIONS & PROCEDURES article in WHEEL ALIGNMENT section.

UPPER CONTROL ARM & BALL JOINT

Removal

1) Raise and support vehicle. Remove front wheel. Remove brake caliper, leaving hose attached, and secure it out of work area. Remove speed sensor from knuckle. See Fig. 2.

2) Disengage clamp speed sensor wiring from upper control arm. Remove cotter pin and nut from upper ball joint. Using Puller (SST 09268-62011), separate upper ball joint from knuckle.

3) Remove splash shield. If removing driver's side strut, remove windshield washer fluid reservoir. On all upper control arm applications, remove upper control arm bolt. See Fig. 1. Remove upper control arm. Measure ball joint rotating torque. See BALL JOINT CHECKING under ADJUSTMENTS & INSPECTION.

Installation

1) Install upper control arm bolt with bolt head toward front of vehicle, leaving it loose at this time. Install upper ball joint. Install and tighten upper ball joint nut to specification. See TORQUE SPECIFICATIONS.

2) Install splash shield and windshield washer fluid reservoir (if removed). Install clamp for speed sensor wiring. Install speed sensor, brake caliper, and front wheel. Tighten bolts and wheel lug nuts to specification.

3) Lower vehicle. Bounce vehicle several times to settle suspension. Position floor jack under lower control arm. Raise vehicle. Remove front wheel.

4) Tighten upper control arm bolt to specification with vehicle weight on lower control arm. Install front wheel. Check wheel alignment. See WHEEL ALIGNMENT SPECIFICATIONS & PROCEDURES article in WHEEL ALIGNMENT section.

UPPER CONTROL ARM BUSHINGS

Upper control arm bushing replacement information is not available from manufacturer.

WHEEL BEARING

Removal

1) Remove hub and knuckle assembly. See HUB & KNUCKLE ASSEMBLY under REMOVAL & INSTALLATION. Clamp knuckle in a soft-jawed vise.

2) Remove grease cap. See Fig. 5. Remove knuckle from vise.

Clamp hub in a soft-jawed vise on wheel studs. DO NOT overtighten vise.

3) Using hammer and chisel, loosen staked area on hub nut. Remove hub nut. Remove Anti-Lock Brake System (ABS) speed sensor rotor. See Fig. 5. Use care not to damage serrations on speed sensor rotor.

4) Remove bolts from dust cover. Using Puller (SST 09950-20017), press hub from knuckle. Remove dust cover. Using puller, remove inner race from hub.

5) Using Puller (SST 09308-00010), remove oil seal. Remove snap ring. Position inner race onto wheel bearing in knuckle. Using Adapter (SST 09608-06100), press wheel bearing from knuckle.

Installation

1) Using Adapter (SST 09608-06200), press NEW wheel bearing into knuckle. Install snap ring. Install inner race onto wheel bearing.

2) Using Oil Seal Installer (SST 09608-32010), tap NEW oil seal into knuckle until surface of oil seal is even with surface of knuckle. Apply grease to oil seal lip.

3) Install dust cover. Install and tighten dust cover bolts to specification. See TORQUE SPECIFICATIONS.

4) Using Adapters (SST 09608-32010 and SST 09608-06040), press hub into knuckle. Install ABS speed sensor rotor. Use care not to damage serrations on ABS speed sensor rotor.

5) Install and tighten NEW hub nut to specification. Stake hub nut against hub. Install grease cap. Reinstall hub and knuckle assembly.

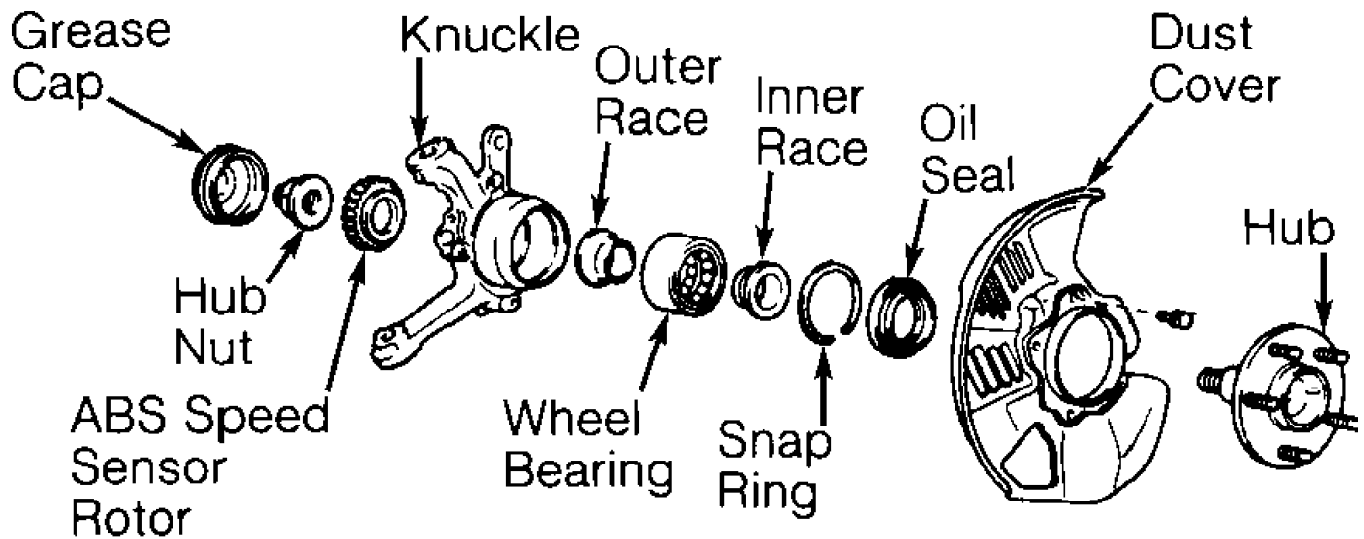

93D84403

Fig. 5: Identifying Knuckle Components
 Courtesy of Toyota Motor Sales, U.S.A., Inc.

TORQUE SPECIFICATIONS

TORQUE SPECIFICATIONS

Application	Ft. Lbs. (N.m)
Adjuster Cam Nut	166 (226)
Ball Joint Nut	

Lower Ball Joint	92	(125)
Upper Ball Joint	76	(103)
Brake Caliper Bolt	87	(118)
Hub Nut	147	(199)
Lower Control Arm Bracket Support Bolt/Nut		
Bolt	33	(45)
Nut	43	(58)
Shaft Nut	21	(29)
Stabilizer Bar Bracket Bolt/Nut	13	(18)
Stabilizer Bar Link Nut	54	(73)
Strut Assembly-To-Body Nut	26	(35)
Strut Assembly-To-Strut Assembly Bracket Bolt ..	106	(144)
Tie Rod-To-Knuckle Nut	36	(49)
Upper Control Arm-To-Subframe Bolt	121	(164)
Wheel Lug Nut	76	(103)

INCH Lbs. (N.m)

ABS Speed Sensor Bolt	71	(8.0)
Dust Cover Bolt	71	(8.0)
