

STARTER

1996 Toyota Supra

1995-96 STARTING & CHARGING SYSTEMS
Toyota Starters

Supra

WARNING: Deactivate air bag system before performing any service operation. For 1995 Supra, see AIR BAG RESTRAINT SYSTEM, for 1996 Supra, see AIR BAG RESTRAINT SYSTEM article in ACCESSORIES & EQUIPMENT.

DESCRIPTION & OPERATION

Supra uses Nippondenso 4-brush, solenoid-actuated, reduction gear type starters, equipped with over-running clutches. The brush holder assembly retains 4 brushes and springs in the starter housing.

Reduction gear type starters contain an integral solenoid attached to drive housing, a reduction idler gear and bearing installed into starter housing, and a clutch drive assembly. The clutch drive assembly is mounted to starter housing and is driven by the reduction idler gear from armature shaft. The brush holder assembly retains 4 brushes and 4 springs in the end cover of field frame housing.

Planetary gear type starters contain a clutch pinion drive assembly mounted in-line with armature shaft. The clutch pinion drive assembly is mounted onto drive end of planetary gear carrier shaft which is driven by armature shaft. The planetary gears increase torque from armature to turn clutch pinion drive assembly.

Use a starter relay to energize starter. Manual transmission vehicles use a clutch start switch and automatic transmission vehicles use a park/neutral switch to energize starter relay. On models with theft deterrent system, theft deterrent system ECU provides ground for starter relay.

TROUBLE SHOOTING

NOTE: See TROUBLE SHOOTING - BASIC PROCEDURES article in GENERAL INFORMATION.

1) If a no-start condition exists and battery is known to be good, connect test light or voltmeter between starter solenoid terminal No. 50 and ground. See Figs. 5 and 6.

2) Turn ignition switch to START position. If test light or voltmeter does not indicate voltage, check main fusible links and large ampere main fuses in engine compartment relay box. If fusible links and fuses are okay, see IGNITION SWITCH CONTINUITY TEST and/or STARTER RELAY TEST under ON-VEHICLE TESTING.

ON-VEHICLE TESTING

NOTE: Before testing, ensure battery is fully charged, battery cables and terminal ends are tight and clean, and engine grounds are secure.

CLUTCH START SWITCH TEST

1) Switch is located above clutch pedal on bracket. Disconnect wiring harness connector from switch.
2) Connect ohmmeter probes to switch terminals. Depress

clutch pedal. If continuity does not exist, adjust or replace clutch start switch. If continuity exists, check circuit to starter relay for open, and check starter relay. See STARTER RELAY TEST.

IGNITION SWITCH CONTINUITY TEST

WARNING: Deactivate air bag system before performing any service operation. For 1995 Supra, see AIR BAG RESTRAINT SYSTEM, for 1996 Supra, see AIR BAG RESTRAINT SYSTEM article in ACCESSORIES & EQUIPMENT.

1) Disconnect negative battery cable. Remove driver's lower instrument panel cover. Remove upper and lower steering column covers if needed. Locate ignition switch wiring harness 8-pin connector. See Figs. 1-2.

2) With ignition switch in LOCK position, there should be no continuity between any terminals. With ignition switch in ACC position, there should be continuity between terminals No. 5 and 7.

3) With ignition switch in ON position, there should be continuity between terminals No. 2 and 3, and between terminals No. 4, 5 and 7. With ignition switch in START position, there should be continuity between terminals No. 1, 2 and 3, and between terminals No. 4, 7 and 8. If continuity is not as specified, replace switch.

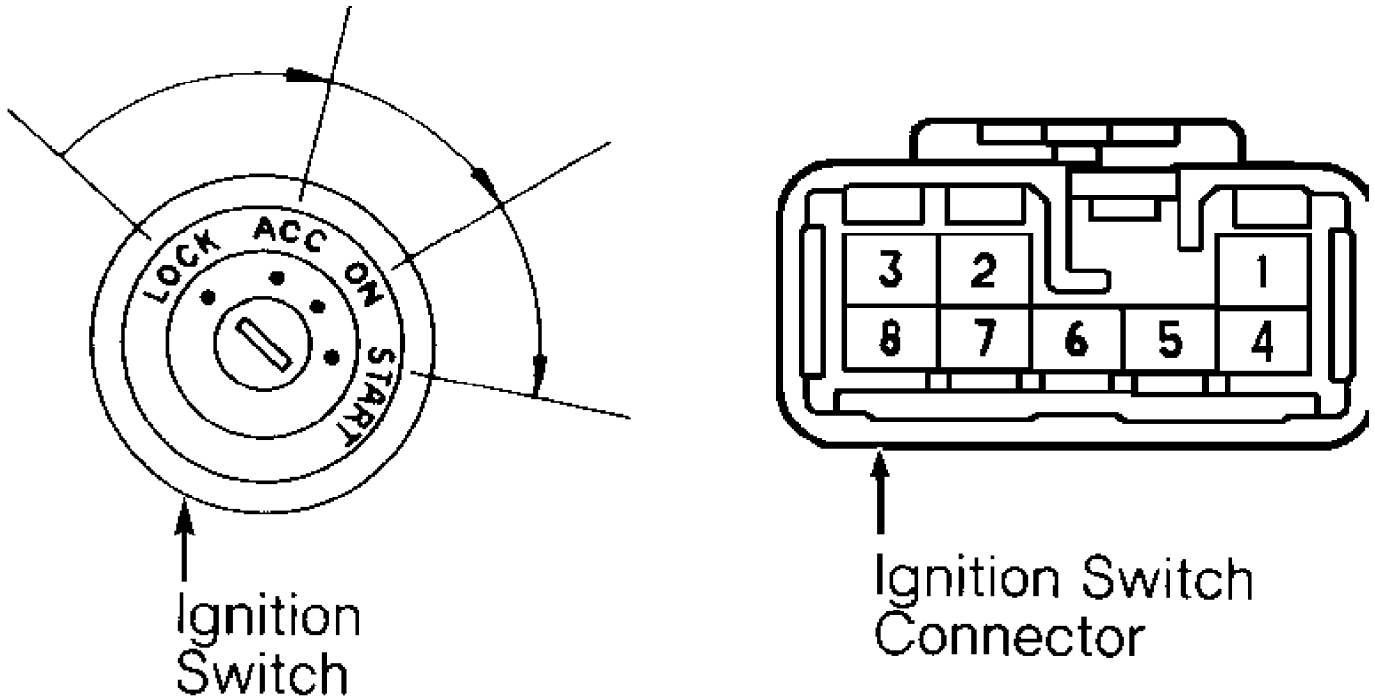

93G82269

Fig. 1: Identifying Ignition Switch 8-Pin Connector
Courtesy of Toyota Motor Sales, U.S.A., Inc.

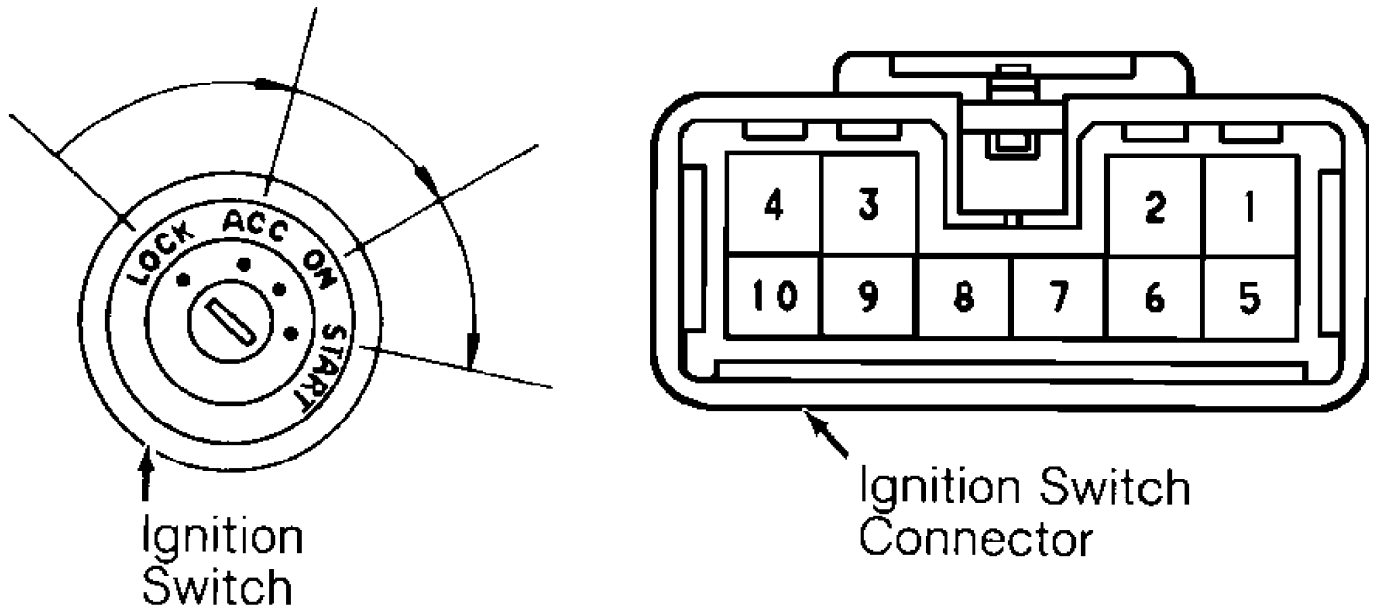

93J82270

Fig. 2: Identifying Ignition Switch 10-Pin Connector
 Courtesy of Toyota Motor Sales, U.S.A., Inc.

PARK/NEUTRAL SWITCH

NOTE: If vehicle will not start with shift lever in Park/Neutral position, verify correct park/neutral switch adjustment. If park/neutral switch is correctly adjusted, verify switch continuity.

Adjusting Park/Neutral Switch

Locate park/neutral switch at transmission or transaxle. Loosen park/neutral position switch bolt(s) and verify shift selector is in "N" position. Align switch shaft groove with neutral basic line on switch. Hold switch in position and tighten bolt(s) to 108 INCH lbs. (12 N.m).

Park/Neutral Switch Continuity Check

Disconnect electrical connector from park/neutral switch at transmission or transaxle. Using ohmmeter, check for continuity at specified terminals with gearshift in proper positions. See Fig. 3. See PARK/NEUTRAL SWITCH CONTINUITY SPECIFICATIONS table. Replace switch if defective.

PARK/NEUTRAL SWITCH CONTINUITY SPECIFICATIONS

Gearshift Position	Continuity Between Terminals
Park	5 & 6, 4 & 7
Reverse	4 & 8
Neutral	5 & 6, 4 & 10
Drive	4 & 9
2	4 & 2
Low	4 & 3

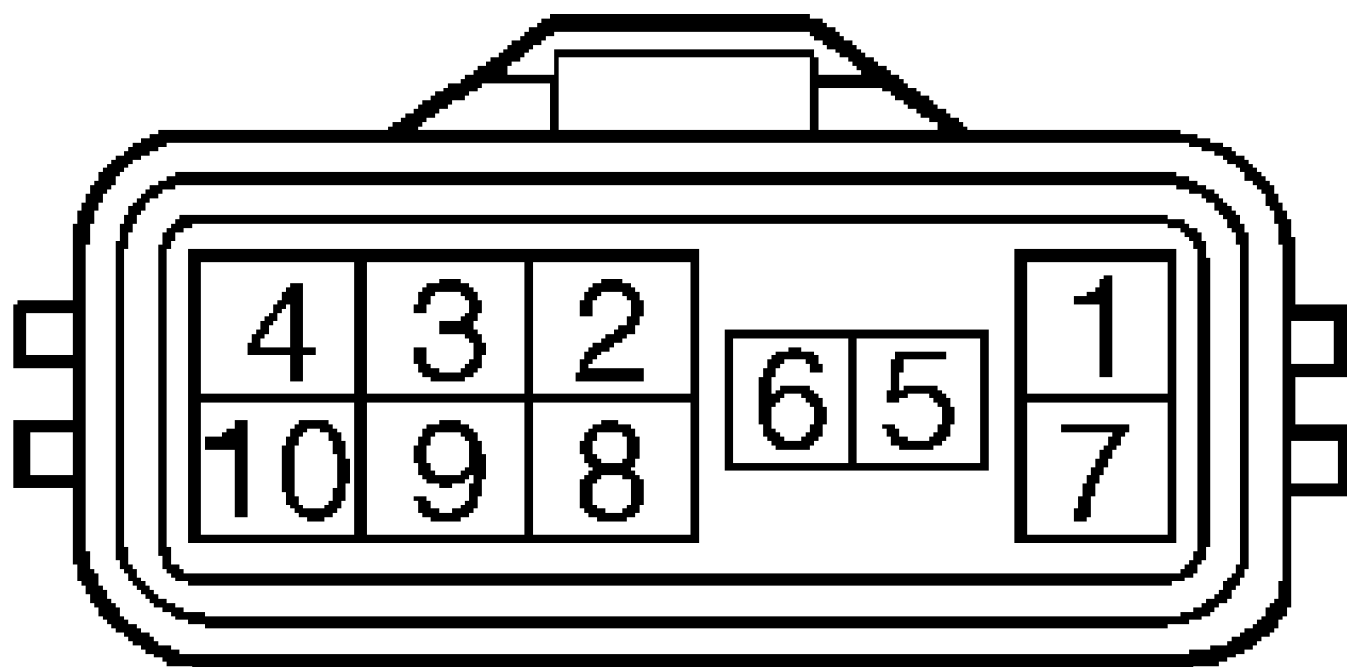

G94E45918

Fig. 3: Identifying Park/Neutral Switch Terminals
 Courtesy of Toyota Motor Sales, U.S.A., Inc.

STARTER RELAY TEST

1) Locate and remove starter relay. See STARTER RELAY LOCATION table. Using ohmmeter, verify continuity between relay terminals No. 1 and 2. See Fig. 4. Continuity should not exist between terminals No. 3 and 5. If continuity is not as indicated, replace relay.

2) Check relay operation by applying battery voltage through terminals No. 1 and 2. See Fig. 4. Continuity should now exist between terminals No. 3 and 5. If relay does not test as indicated, replace relay.

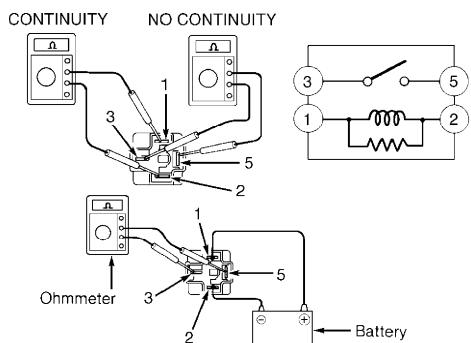

93AR2271
 Fig. 4: Testing Starter Relay
 Courtesy of Toyota Motor Sales, U.S.A., Inc.

STARTER RELAY LOCATION

Application	Location
Supra	In Engine Compartment Relay Box

BENCH TESTING

NO-LOAD TEST

CAUTION: DO NOT engage starter solenoid for more than 5 seconds during testing, or damage to coil winding will result.

NOTE: Starter type and kilowatt (kW) rating can be found on a metal label attached to side of starter.

1) Remove starter. Connect ammeter in series between starter motor terminal No. 30 (battery terminal) and a fully charged 12-volt battery. Connect battery negative to starter case ground. See Figs. 5 and 6. Connect voltmeter to battery to observe voltage draw readings.

2) Connect remote starter or jumper wire to terminal No. 30 and to terminal No. 50 to engage starter. Starter drive pinion gear should extend quickly and spin smoothly. Verify starter amperage draw and battery voltage draw to be within specifications. See NO-LOAD TEST SPECIFICATIONS table. Replace starter if not within specification.

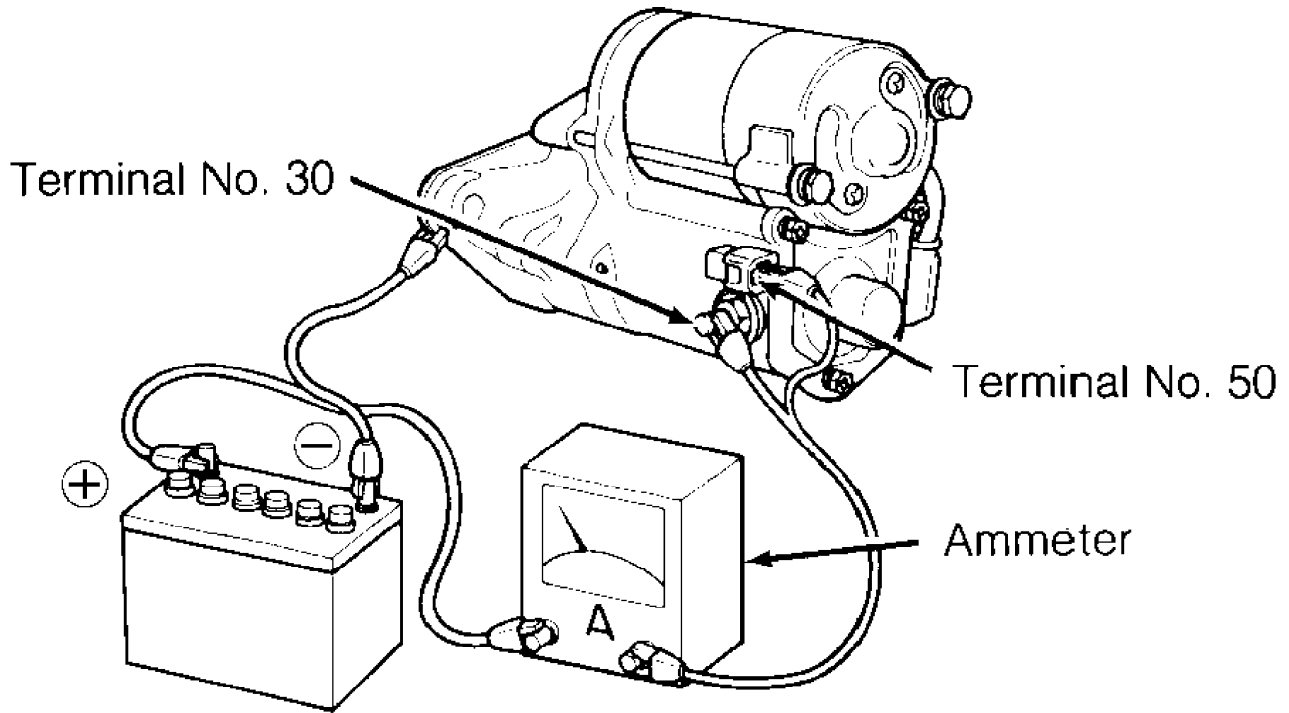

93102164

Fig. 5: Testing Starter No-Load (Reduction Gear Type)
Courtesy of Toyota Motor Sales, U.S.A., Inc.

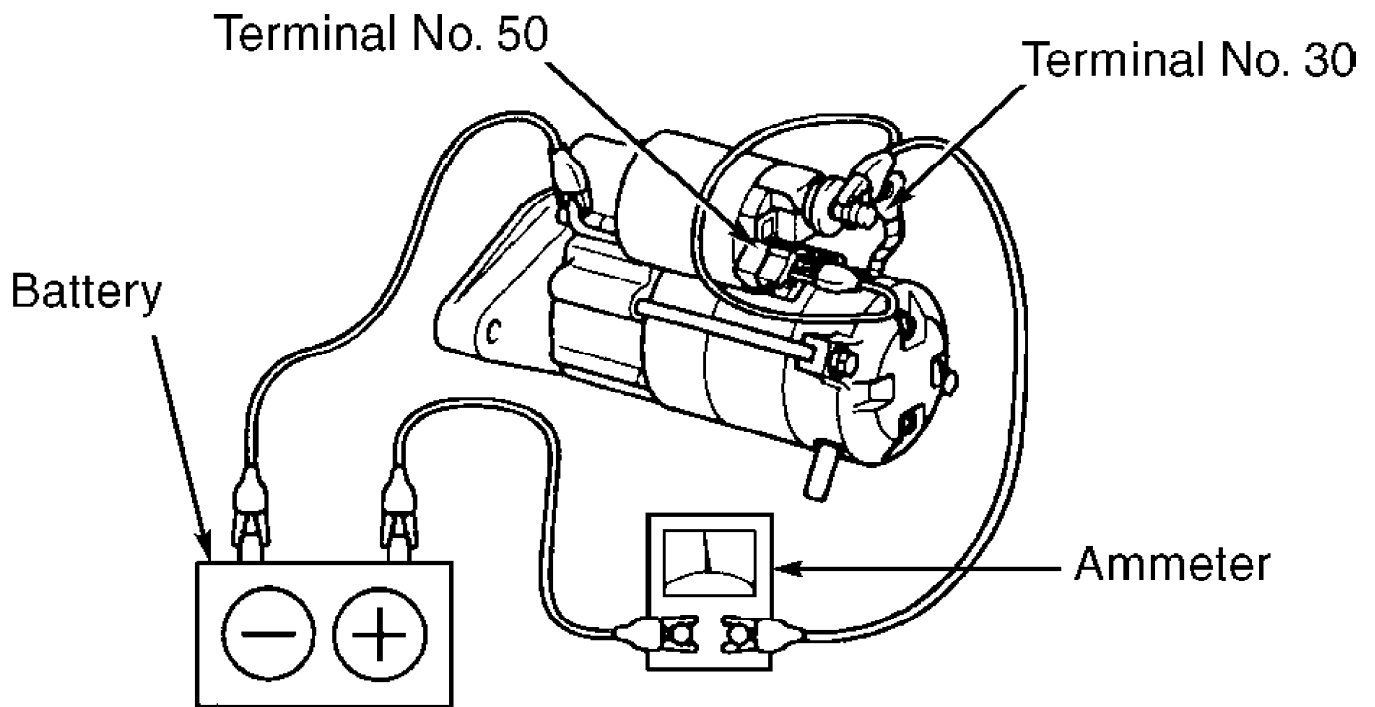

96F06127

Fig. 6: Testing Starter No-Load (Planetary Gear Type)
 Courtesy of Toyota Motor Sales, U.S.A., Inc.

NO-LOAD TEST SPECIFICATIONS

Application	Max. Amps @ (Volts)	RPM
1.4 kW	90 (11.5)	3000

SOLENOID TESTS

CAUTION: DO NOT engage starter solenoid for more than 5 seconds during testing, or damage to coil winding will result.

Pull-In Coil Test

Disconnect field coil lead from terminal "C". Connect jumper wires from negative battery terminal to terminal "C" and to starter housing. When wire is connected from positive battery terminal to terminal No. 50, clutch pinion gear should extend fully. See Figs. 7-9. If clutch pinion gear does not move, replace solenoid. If clutch pinion gear does move, go to next test.

Hold-In Coil Test

With battery connected as in previous test and clutch pinion gear still extended, disconnect jumper wire from starter terminal "C". See Figs. 7-9. Clutch pinion gear should remain extended. If clutch pinion gear does not remain extended, replace solenoid. If clutch pinion gear does remain extended, go to next test.

Drive Pinion Return Test

Disconnect jumper wire from negative battery terminal to starter housing. See Figs. 7-9. Pinion gear should now retract. If it does not retract, replace solenoid.

STARTER COMPONENT INSPECTION

Armature Coil

1) Using ohmmeter, check for continuity between armature coil core and insulation between commutator segments. If continuity is present, replace armature. Check armature for shorts using a growler. Replace armature as necessary.

2) Check for continuity between segments of commutator. If continuity is not present between any segment, replace armature.

Brushes & Springs

1) Check brush length. If length is less than specification, replace brushes. See appropriate NIPPONDENSO STARTER SPECIFICATIONS table under STARTER SPECIFICATIONS.

2) Check brush holders, springs, spring clip and insulation between positive and negative holders. Verify no continuity exists between positive and negative brush holders. Repair or replace components as needed.

Clutch Assembly & Gears

1) Inspect teeth on pinion gear, idler gear and clutch assembly for wear or damage. If damaged, replace gear or clutch assembly and inspect flywheel ring gear for wear or damage.

2) Inspect clutch pinion gear by rotating pinion gear. Depending on engine, pinion gear will rotate freely in one direction and lock when rotated in opposite direction. On Supra, clutch pinion gear will lock when rotated in a clockwise direction.

NOTE: Starter type and kilowatt (kW) rating can be found on a metal label attached to side of starter.

Commutator

1) If commutator surface is dirty or burnt, it can be cleaned with No. 400 grit sandpaper or on a lathe. If commutator runout (out-of-round) is more than .002" (.05 mm), turn commutator on a lathe. Wear or cutting limit of commutator diameter is 1.06" (27 mm) for 0.8 kW starter, 1.14" (29.0 mm) for 1.0, 1.2, 1.4, 1.6 and 1.8 kW starter, and 1.34" (34 mm) for 2.0 kW starter. If commutator diameter is less than minimum, replace armature.

2) Ensure undercut depth between commutator segments are clean, free of debris, and that edges are smooth. Minimum undercut depth is .008" (.20 mm). If undercut depth is less than minimum, use a hacksaw blade to correct to a depth of .008-.024" (.20-.60 mm).

Field Frame (Field Coil)

Verify continuity between lead wire and field coil brush lead. If continuity is not present, replace field coil. Verify there is no continuity between field coil end and field frame. If continuity exists, replace or repair field frame.

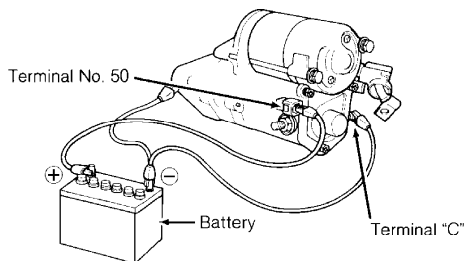

93B02165

Fig. 7: Testing Starter Solenoid Pull-In Coil Test
Courtesy of Toyota Motor Sales, U.S.A., Inc.

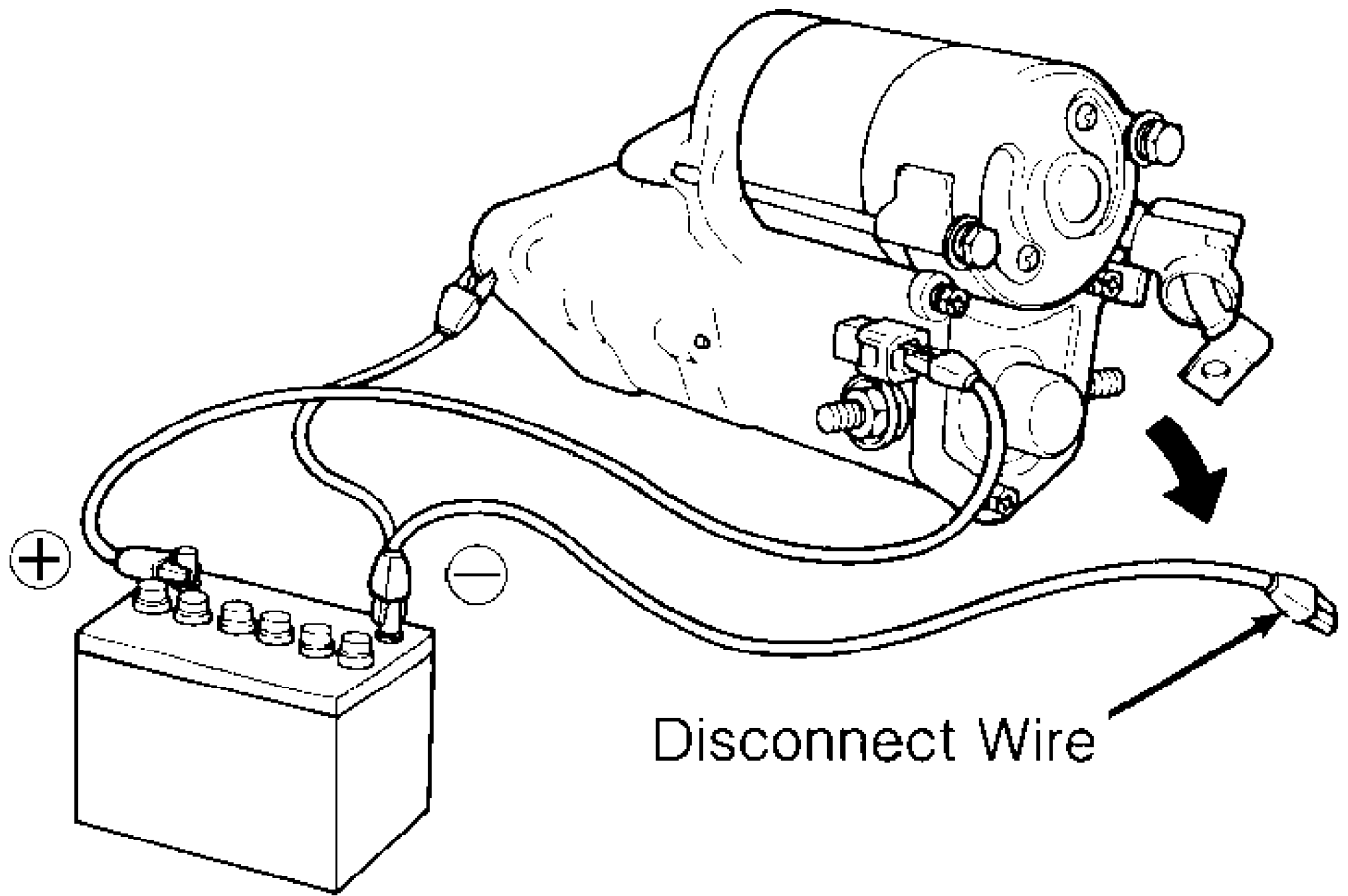

93D02166

Fig. 8: Testing Starter Solenoid Hold-In Coil Test
 Courtesy of Toyota Motor Sales, U.S.A., Inc.

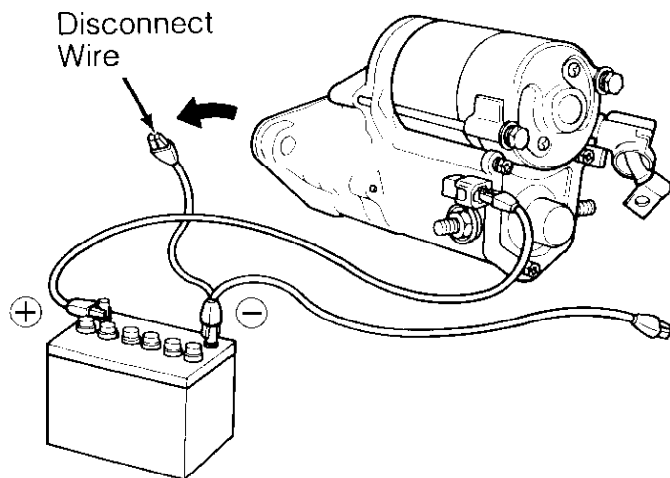

93F02167

Fig. 9: Testing Starter Solenoid Drive Pinion Return Test
 Courtesy of Toyota Motor Sales, U.S.A., Inc.

REMOVAL & INSTALLATION

STARTER MOTOR

Removal & Installation

Disconnect negative battery cable and remove starter. To install, reverse removal procedure. See TORQUE SPECIFICATIONS.

OVERHAUL

NOTE: Overhaul procedures are not available from manufacturer. For exploded views of starters, see Figs. 10.

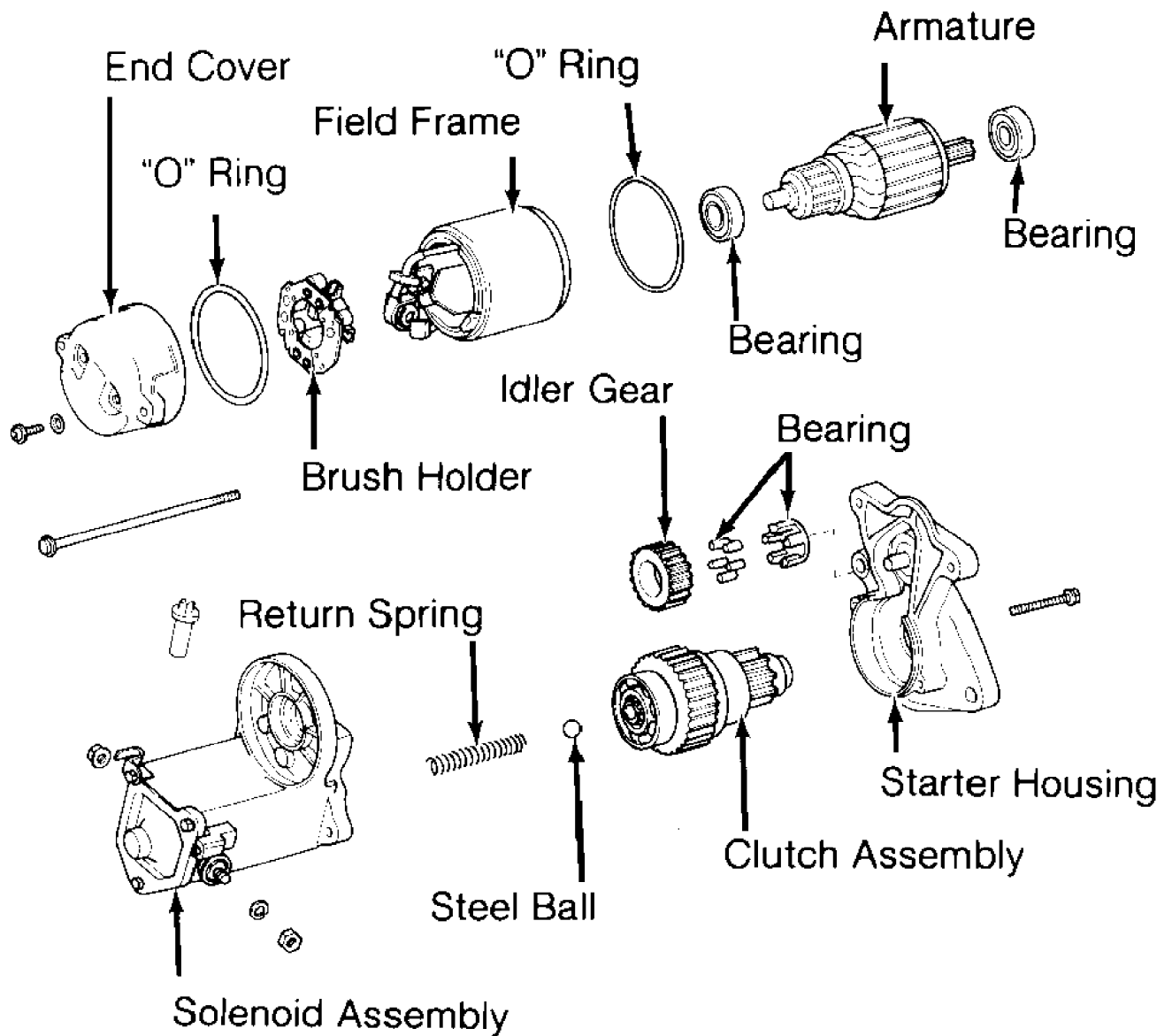

92H01588

Fig. 10: Exploded View Of Gear Reduction Starter
Courtesy of Toyota Motor Sales, U.S.A., Inc.

STARTER SPECIFICATIONS

NIPPONDENSO STARTER SPECIFICATIONS (1995 MODELS)

Application	Specification
Brush Minimum Length394" (10.0 mm)

NIPPONDENSO STARTER SPECIFICATIONS (1996 MODELS)

Application	Specification
Brush Minimum Length394" (10.0 mm)

TORQUE SPECIFICATIONS

TORQUE SPECIFICATIONS

Application	Ft. Lbs. (N.m)
Starter Mounting Bolts	29 (39)

WIRING DIAGRAMS

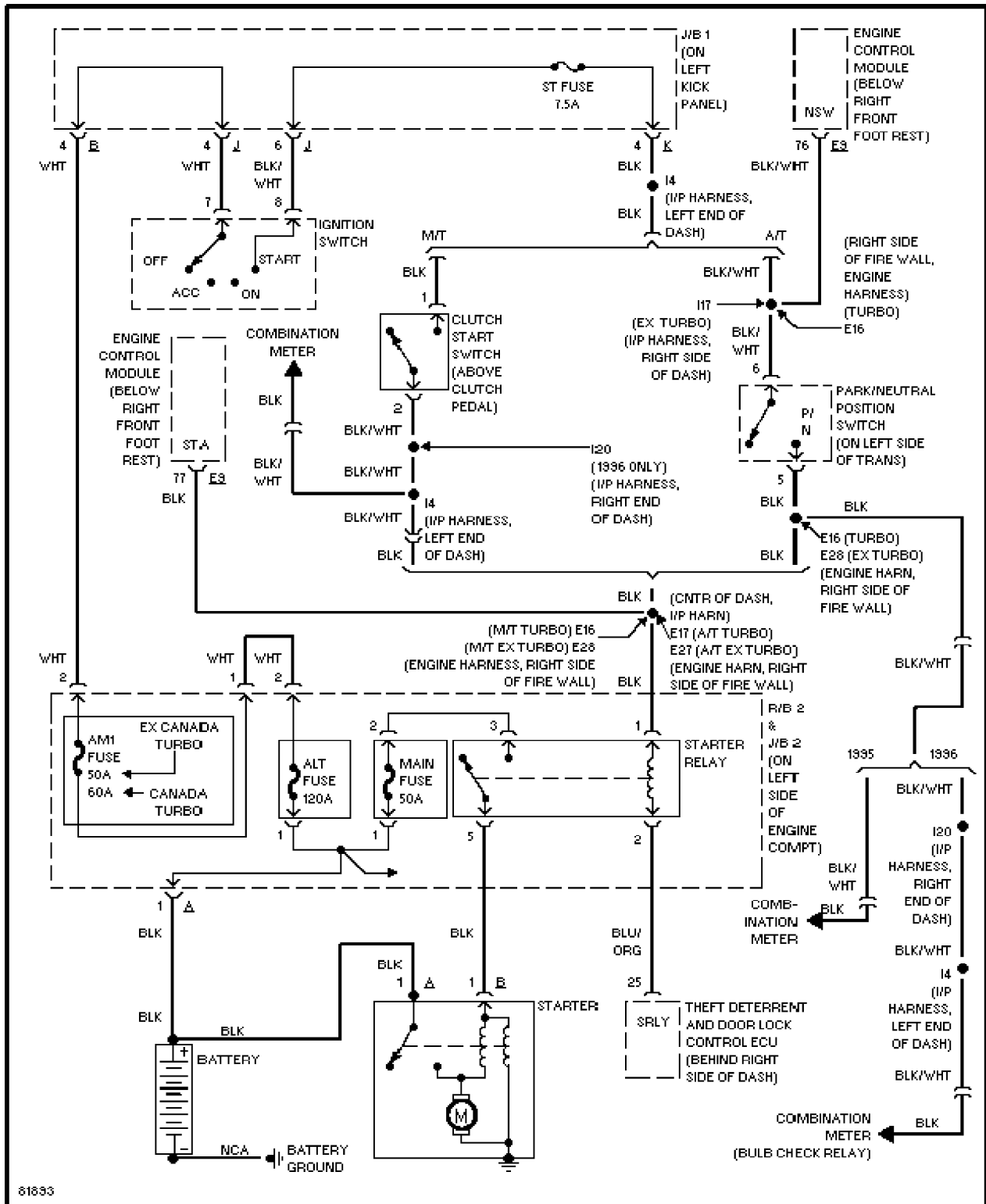

Fig. 11: Starting System Wiring Diagram (1995-96)