

MAINTENANCE OPERATIONS ENGINE

Cold Engine Operations

1. REPLACE TIMING BELT

- (a) Remove the timing belt.
(See page EG-38)
- (b) Install the timing belt.
(See page EG-47)

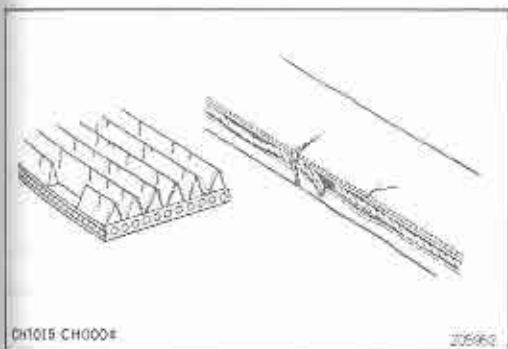

2. INSPECT DRIVE BELT

HINT: A belt tensioner is used, so checking the belt tension is not necessary.

- (a) Visually check the drive belt for excessive wear, frayed cords, etc.

If necessary, replace the drive belt.

HINT:

- Cracks on the rib side of a drive belt are considered acceptable. If the drive belt has chunks missing from the ribs, it should be replaced.
- The drive belt tension can be released by turning the belt tensioner clockwise.

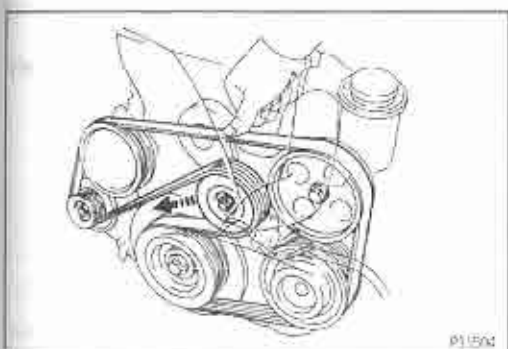
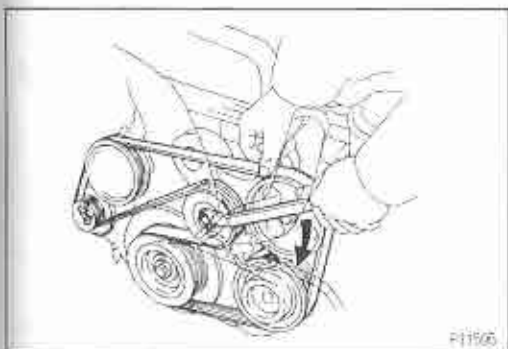

- (b) Check the belt tensioner operation.

- Check that the belt tensioner moves downward when the drive belt is pressed down at the points indicated in the illustration with approx. 98 N (10 kgf, 22.0 lbf) of force.
- Check the alignment of the belt tensioner pulley to make sure the drive belt will not slipped off the pulley.

If necessary, replace the belt tensioner.

- Check that the arrow mark on the belt tensioner falls within area A of the scale.

If it is outside area A, replace the drive belt.

HINT:

- When a new belt is installed, it should be within area B. If not, the drive belt is not correct.

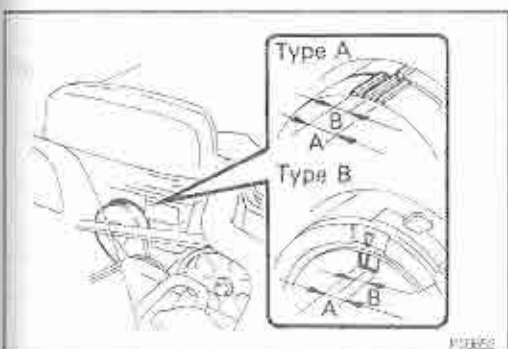

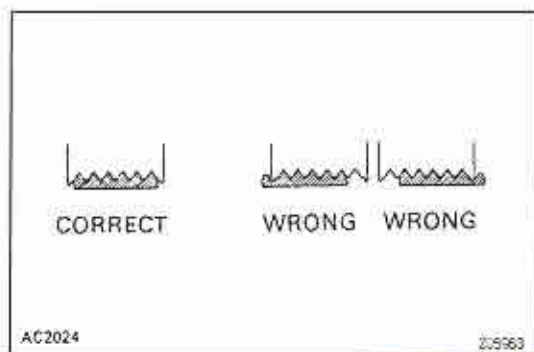

- After installing a drive belt, check that it fits properly in the ribbed grooves.
- Check by hand to confirm that the belt has not slipped out of the groove on the bottom of the pulley.

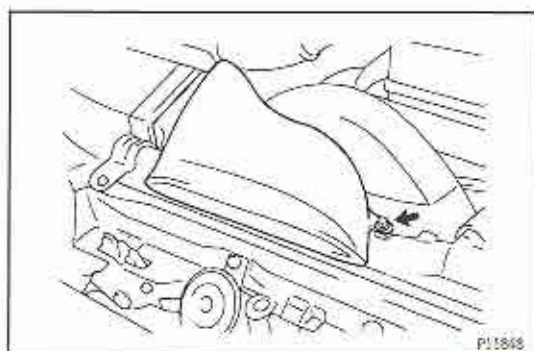

3. INSPECT AIR FILTER

- (a) Remove the bolt and air cleaner duct.

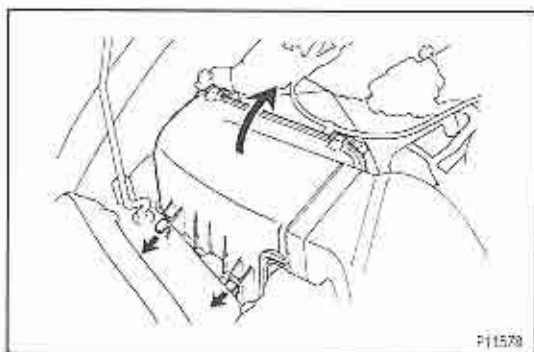

- (b) Open the air cleaner cap.

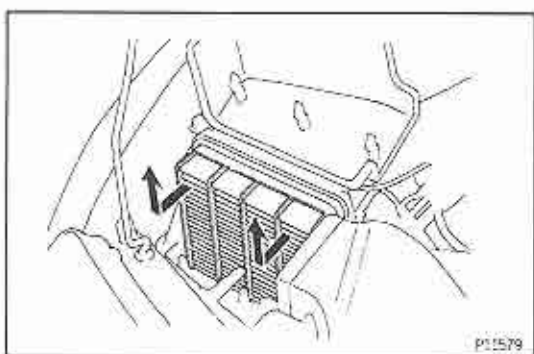

- (c) Remove the air filter.
 (d) Visually check that the air filter is not excessively damaged or oily.
 If necessary, replace the air filter.

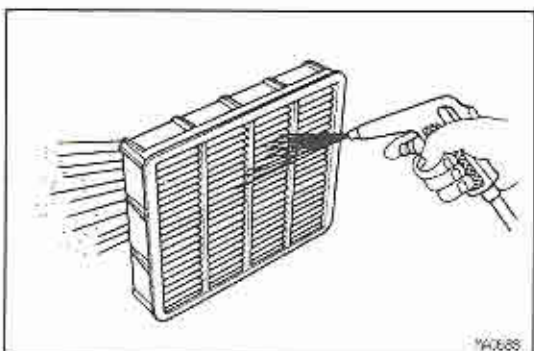

- (e) Clean the air filter with compressed air.
 First blow from the inside thoroughly, then blow off the outside of the air filter.
 (f) Reinstall the air filter and air cleaner cap.
 (g) Reinstall the air cleaner duct.

4. REPLACE AIR FILTER

- Replace the air filter with a new one.

5. REPLACE SPARK PLUGS

(a) 2JZ – GE:

Remove the throttle body.

(See SFI System on page EG – 354)

(b) Remove the No.3 timing belt cover.

(c) 2JZ – GE:

Remove the cylinder head rear cover.

(d) Disconnect the high – tension cords at the rubber boot. Do not pull on the high – tension cords.

NOTICE: Pulling on or bending the cords may damage the conductor inside.

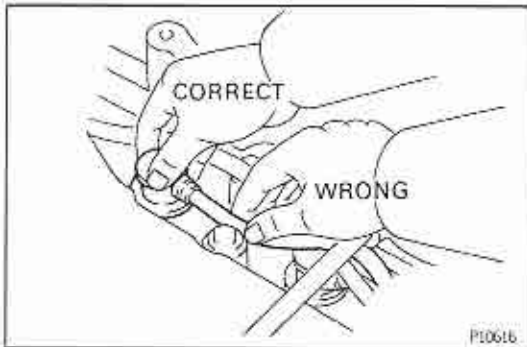

(e) Using a 16 mm plug wrench, remove the 6 spark plugs.

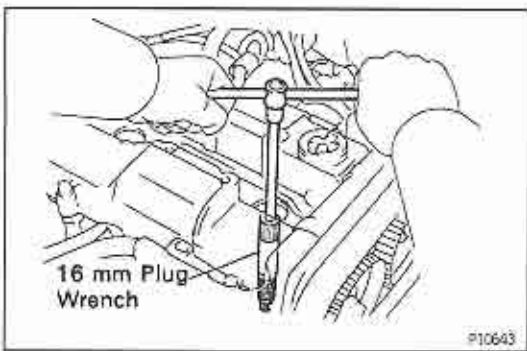

(f) Check the electrode gap of new spark plugs.

Correct electrode gap:

1.1 mm (0.043 in.)

Recommended spark plug:

2JZ – GE

PK16R11 for ND

BKR5EP11 for NGK

2JZ – GTE

PK20R11 for ND

BKR6EP11 for NGK

NOTICE: If adjusting the gap of a new spark plug, bend only the base of the ground electrode. Do not touch the tip.

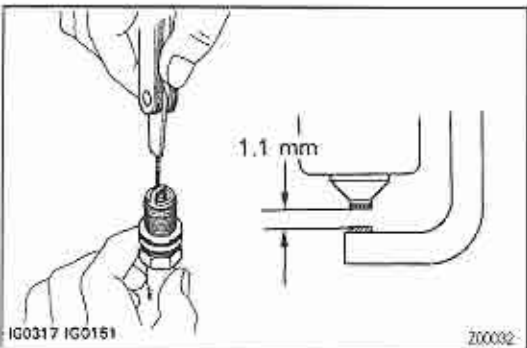

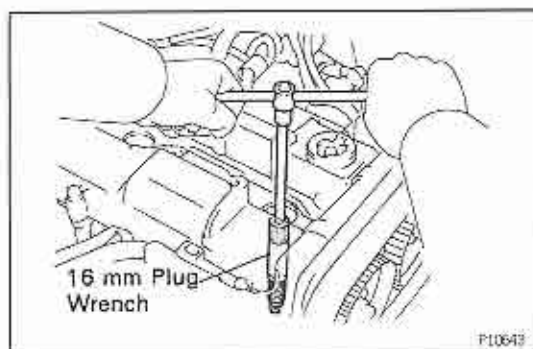

- (g) Using a 16 mm plug wrench, reinstall the 6 spark plugs.

Torque: 18 N·m (180 kgf·cm, 13 ft·lbf)

- (h) Reconnect the high-tension cords.
 (i) 2JZ-GE:
 Reinstall the cylinder head rear cover.
 (j) Reinstall the No.3 timing belt cover.
 (k) 2JZ-GE:
 Reinstall the throttle body.

(See SFI System on page EG-358)

6. REPLACE ENGINE OIL AND OIL FILTER

(See Lubrication System on page EG-598)

2JZ-GE:

Oil grade:

API grade SG or SH Energy - Conserving II or ILSAC multigrade engine oil.

Recommended viscosity is as shown in the illustration, with SAE 5W-30 being the preferred engine oil.

Drain and refill capacity:

w/ Oil filter change

5.2 liters (5.5 US qts, 4.6 Imp. qts)

w/o Oil filter change

4.9 liters (5.2 US qts, 4.3 Imp. qts)

2JZ-GTE:

Oil grade:

API grade SG or SH Energy - Conserving II or ILSAC multigrade engine oil.

Recommended viscosity is as shown in the illustration.

Drain and refill capacity:

w/ Oil filter change

5.0 liters (5.3 US qts, 4.3 Imp. qts)

w/o Oil filter change

4.7 liters (5.0 US qts, 4.1 Imp. qts)

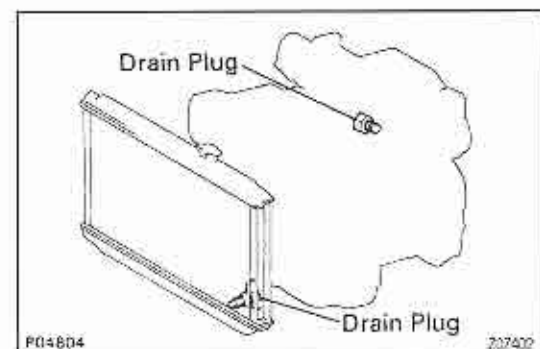
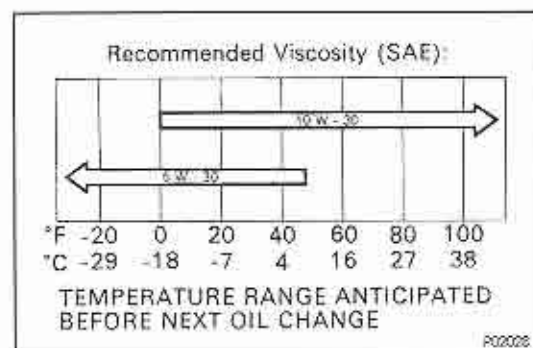
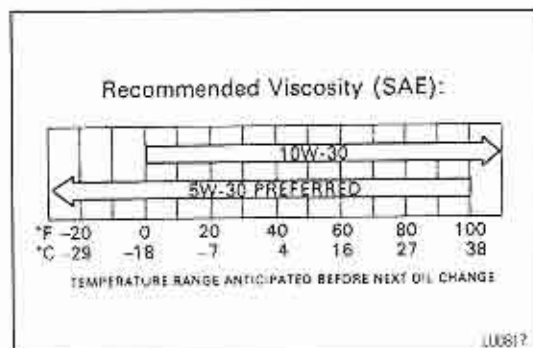

7. REPLACE ENGINE COOLANT

(See Cooling System on page EG-546)

Capacity (w/ Heater):

2JZ-GE M/T

7.3 liters (7.7 US qts, 6.4 Imp. qts)

2JZ-GE A/T

8.3 liters (8.8 US qts, 7.3 Imp. qts)

2JZ—GTE M/T

9.3 liters (10.0 US qts, 8.4 Imp. qts)

2JZ—GTE A/T

9.4 liters (9.9 US qts, 8.3 Imp. qts)

HINT:

- Use a good brand of ethylene—glycol base coolant and mix it according to the manufacturer's directions.
- Using coolant which includes more than 50 % ethylene—glycol (but not more than 70 %) is recommended.

NOTICE:

- Do not use a alcohol type coolant.
- The coolant should be mixed with demineralized water or distilled water.

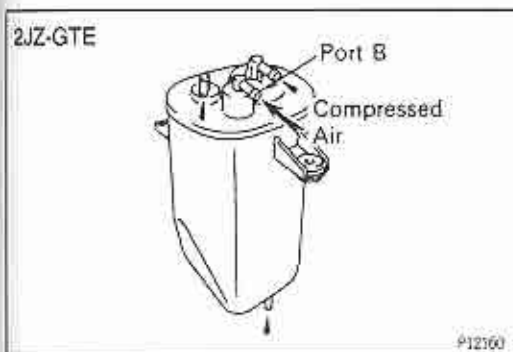
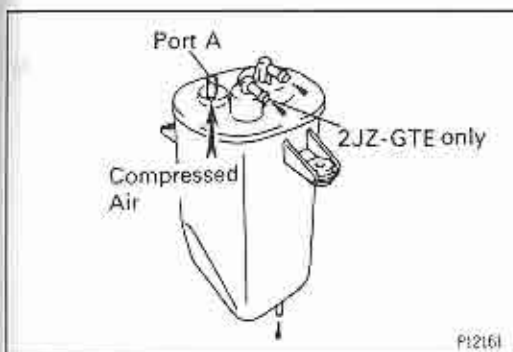
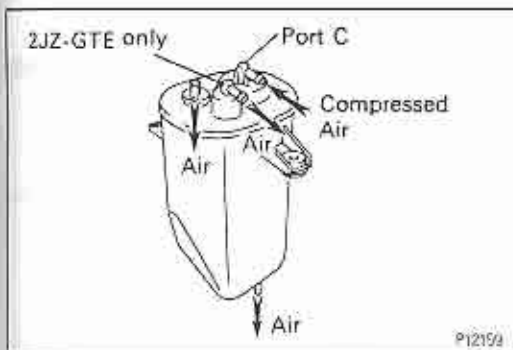

8. INSPECT CHARCOAL CANISTER

- Remove the charcoal canister.
- Visually inspect the canister case.
- Check for clogged each port and stuck check valve.
 - Using low compressed air (4.71 kPa (48 gf/cm², 0.68 psi)), blow into port C and check that air flows without resistance from the other ports.

- Blow low compressed air (4.71 kPa (48 gf/cm², 0.68 psi)) into port A and check that air does not flow from the other ports.

If operation is not as specified, replace the charcoal canister.

- **2JZ—GTE:**
Blow low compressed air (4.71 kPa (48 gf/cm², 0.68 psi)) into port B and check that air does not flow from the other ports.

If operation is not as specified, replace the charcoal canister.

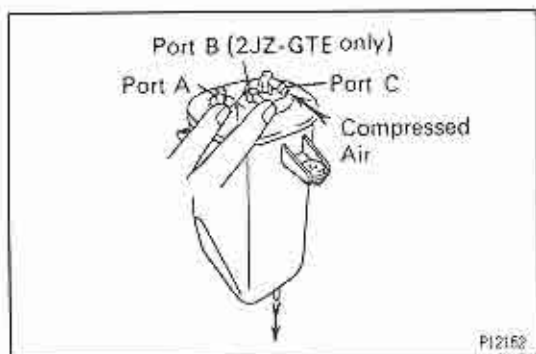

- (d) Clean the filter in the canister.
Clean the filter by blowing 294 kPa (3 kgf/cm², 43 psi) of compressed air into port C while holding port A and B (2JZ-GTE only) closed.

NOTICE:

- Do not attempt to wash the canister.
- No activated carbon should come out.

- (e) Reinstall the charcoal canister.

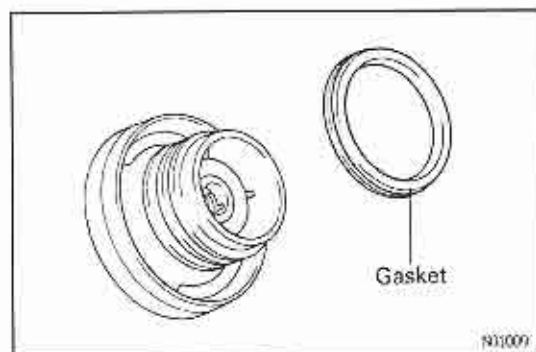
**9. REPLACE GASKET IN FUEL TANK CAP**

- (a) Remove the old gasket from the tank cap. Do not damage the cap.
(b) Install a new gasket by hand.
(c) Check the cap for damage or cracks.
(d) Install the cap and check the torque limiter.

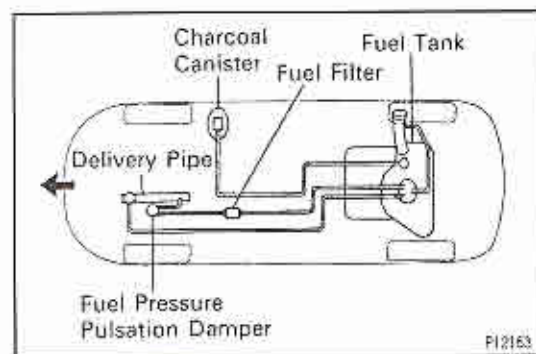
**10. INSPECT FUEL LINES AND CONNECTIONS**

Visually check the fuel lines for cracks, leakage, loose connections, deformation or tank band looseness.

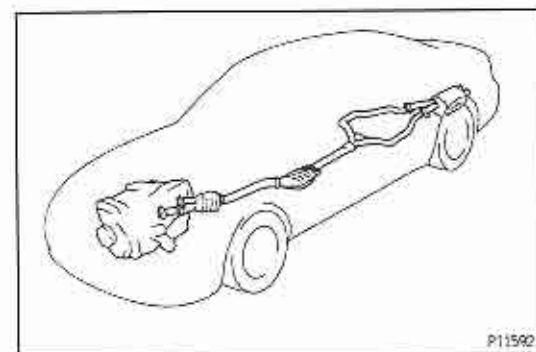
**11. INSPECT EXHAUST PIPES AND MOUNTINGS**

Visually check the pipes, hangers and connections for severe corrosion, leaks or damage.

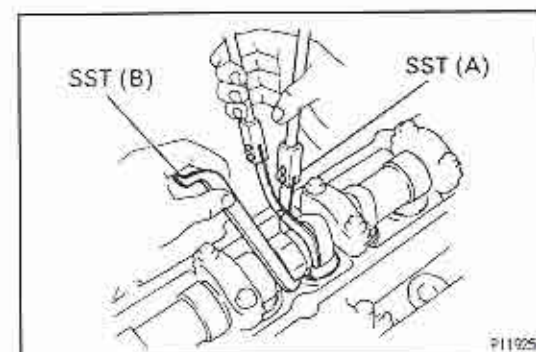
**12. ADJUST VALVE CLEARANCE**

(See Engine Mechanical on page EG-16)

Valve clearance (Cold):

Intake

0.15 - 0.25 mm (0.006 - 0.010 in.)

Exhaust

0.25 - 0.35 mm (0.010 - 0.014 in.)

BRAKES

13. INSPECT BRAKE LINE PIPES AND HOSES

HINT: Check in a well lighted area. Check the entire circumference and length of the brake hoses using a mirror as required. Turn the front wheels fully right or left before checking the front brake.

- (a) Check all brake lines and hoses for:
- Damage
 - Wear
 - Deformation
 - Cracks
 - Corrosion
 - Leaks
 - Bends
 - Twists
- (b) Check all clamps for tightness and connections for leakage.
- (c) Check that the hoses and lines are clear of sharp edges, moving parts and the exhaust system.
- (d) Check that the lines installed in grommets pass through the center of the grommets.

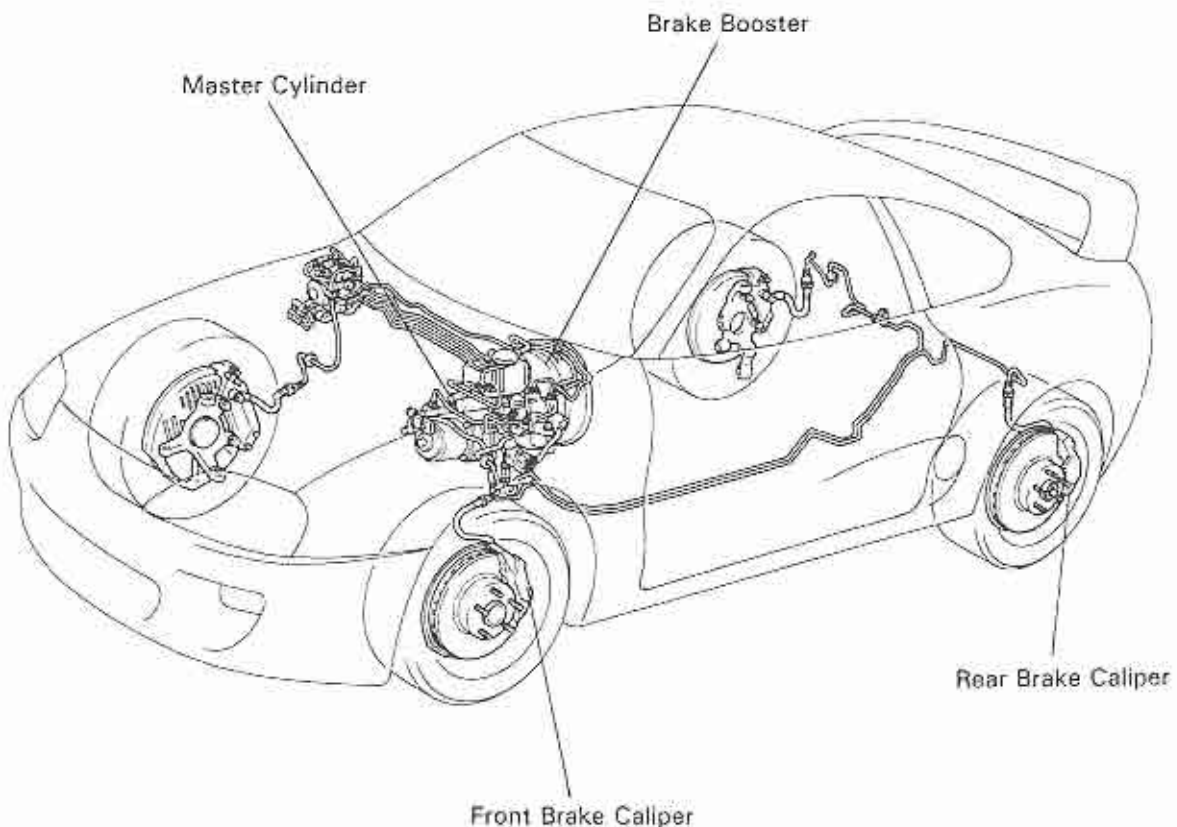
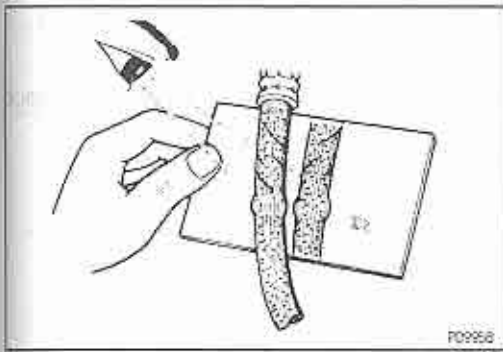

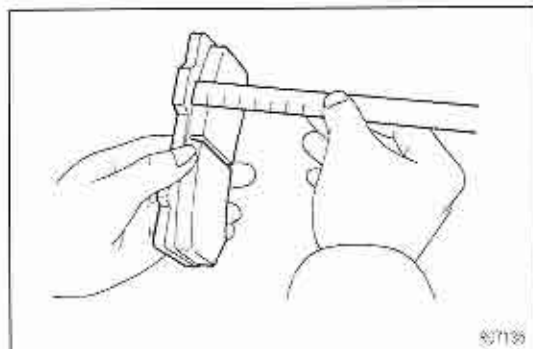

14. INSPECT BRAKE PADS AND DISCS FOR FRONT AND REAR

- (a) Check the thickness of the disc brake pads and check for irregular wear.

Minimum pad thickness:

1.0 mm (0.039 in.)

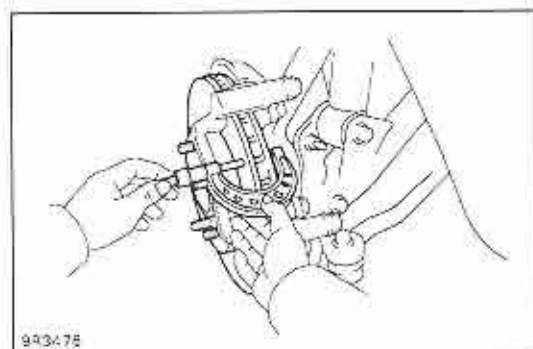

HINT: If a squealing or scraping noise comes from the brake during driving, check the pad wear indicator to see if it is contacting the disc rotor. If so, the disc pad should be replaced.

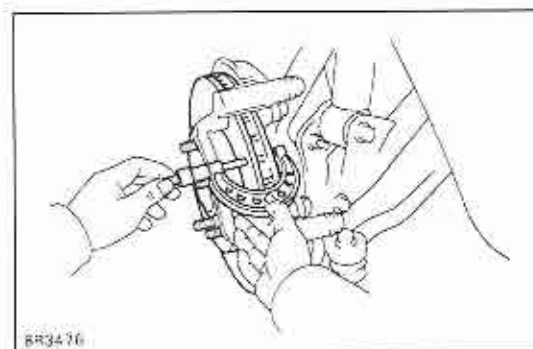

- (b) Check the disc for wear or runout.

Minimum disc thickness:

Front

30.0 mm (1.181 in.) for 2JZ-GE

28.0 mm (1.102 in.) for 2JZ-GTE

Rear

15.0 mm (0.591 in.)

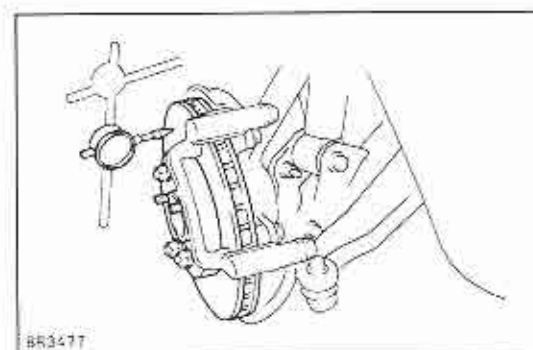

- (c) Check the disc for runout.

Maximum disc runout:

0.05 mm (0.0020 in.)

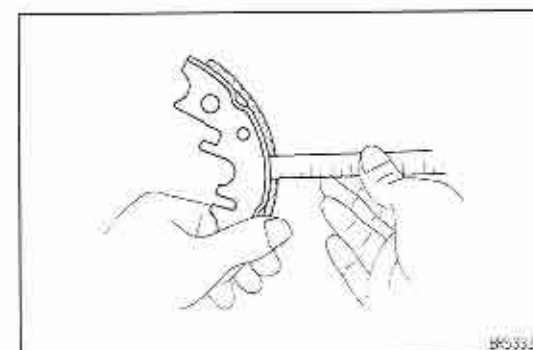

15. INSPECT BRAKE LININGS AND DRUMS FOR PARKING BRAKE

- (a) Check the lining — to — drum contact condition and lining wear.

Minimum lining thickness:

1.0 mm (0.039 in.)

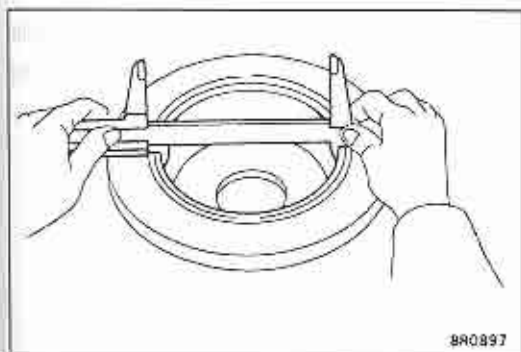

- (b) Check the brake drums for scoring or wear.
Maximum drum inside diameter:
191 mm (7.520 in.)
- (c) Clean the brake parts with a damp cloth.
NOTICE: Do not use compressed air to clean the brake parts.
- (d) Settle the parking brake shoes and drum. When performing the road test in item 25, do the following:
 - Drive the vehicle at approx. 50 km/h (30 mph) on a safe, level and dry road.
 - With the parking brake lever pushed in, pull on the lever with 88 N (9 kgf, 20 lbf) of force.
 - Drive the vehicle for approx. 400 meters (1/4 mile) in this condition.
 - Repeat this procedure 2 or 3 times.
 - Check parking lever travel.
 If necessary, adjust the parking brake.

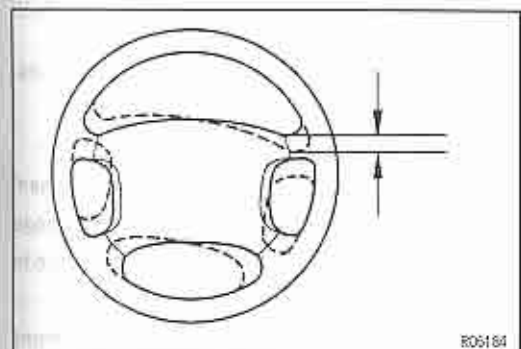

CHASSIS

MA03X-01

16. INSPECT STEERING LINKAGE

- (a) Check the steering wheel freeplay.

Maximum freeplay:
30 mm (1.18 in.)

With the vehicle stopped and pointed straight ahead, rock the steering wheel gently back and forth with light finger pressure.

- (b) Check the steering linkage for looseness or damage. Check that:

- Tie rod ends do not have excessive play.
- Dust seals and boots are not damaged.
- Boot clamps are not loose.

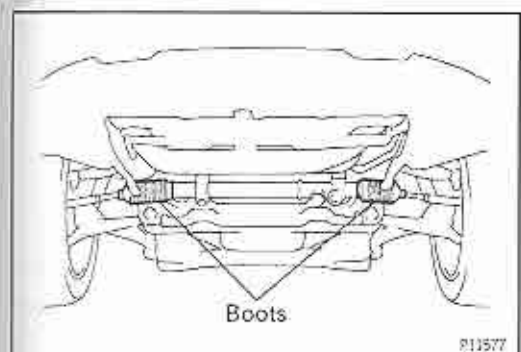

17. INSPECT SRS AIRBAG

(Driver Airbag)

Visually inspect the steering wheel pad (airbag and inflator).

- Use the diagnosis check to check if there are abnormalities.
- Check that there are no cuts, cracks or noticeable color changes on the surface of the steering wheel pad or in the center groove of the pad.

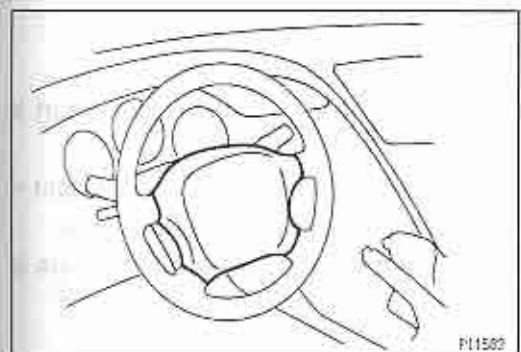

- Remove the steering wheel pad from the vehicle and check the wiring and steering wheel for damage and corrosion due to rusting, etc. If necessary, replace the steering wheel pad.

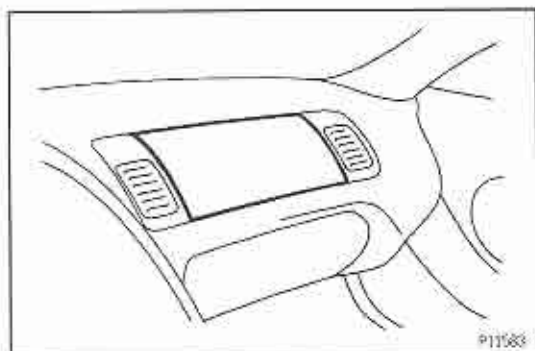

(Front Passenger Airbag)

Visually inspect the front passenger airbag assembly (airbag and inflator).

- Use the diagnosis check to check if there are abnormalities.
- Check that there are no cuts, cracks or noticeable color changes in the front passenger airbag door.
- Remove the front passenger airbag assembly from the vehicle and check the wiring and front passenger airbag door for damage and corrosion due to rusting, etc.

If necessary, replace the front passenger airbag assembly.

CAUTION:

- For removal and replacement of the steering wheel pad or front passenger airbag assembly, see page RS-19 or 31 and be sure to perform the operation in the correct order.
- Before disposing of the steering wheel pad or front passenger airbag assembly must first be deployed by using SST (See page RS-15).

18. INSPECT STEERING GEAR HOUSING OIL

Check the steering gear housing for oil leakage.

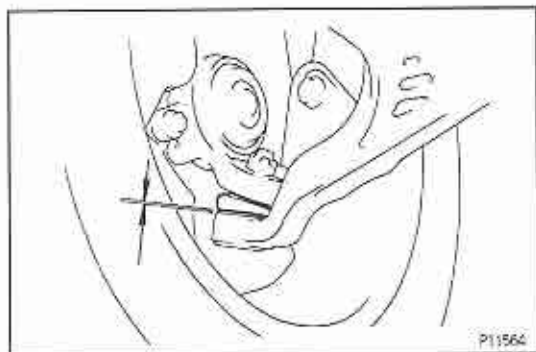

19. INSPECT BALL JOINTS AND DUST COVERS

(a) Inspect the ball joints for excessive looseness.

- Jack up the front of the vehicle and support it with stands.
- Make sure the front wheels are in a straight-ahead position, and depress the brake pedal.
- Jack up the lower suspension arm until there is about half a load on the front coil spring.

- Move the front wheel up and down and check that the ball joint has no excessive play.

Maximum lower ball joint vertical play:

0.3 mm (0.012 in.)

If the play is greater than maximum, replace the ball joint.

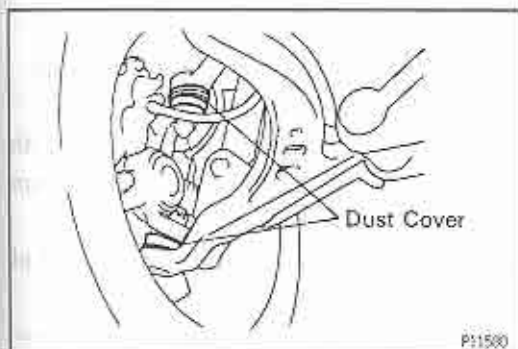

- (b) Visually check the dust covers for damage.

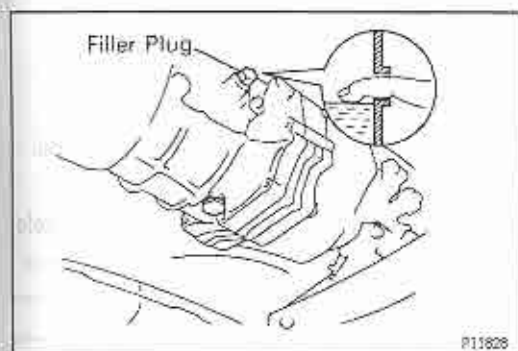

20. INSPECT TRANSMISSION AND DIFFERENTIAL OIL

A. Inspect manual transmission oil

- (a) Visually check the transmission for fluid and leakage. If leakage is found, check for the cause and repair. *
- (b) Remove the filler plug, and feel inside the hole with your finger. Check that the oil comes to within 5 mm (0.20 in.) of the bottom edge of the filler hole. If the level is low, add oil until it begins to run out of the filler hole.

Transmission oil: See item 21 (A)

- (c) Reinstall the filler plug securely.

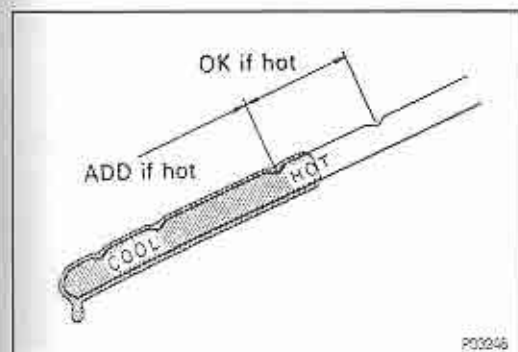

B. Inspect automatic transmission fluid

- (a) Visually check the transmission for fluid and leakage. If leakage is found, check for the cause and repair.
- (b) Check the fluid level with the engine idling and shift lever at "P" position. If the level is low, add fluid.

Transmission fluid: See item 21 (B)

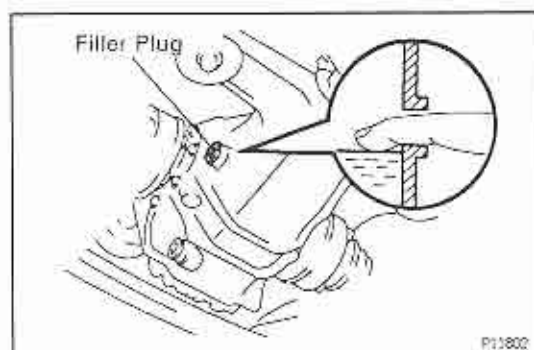
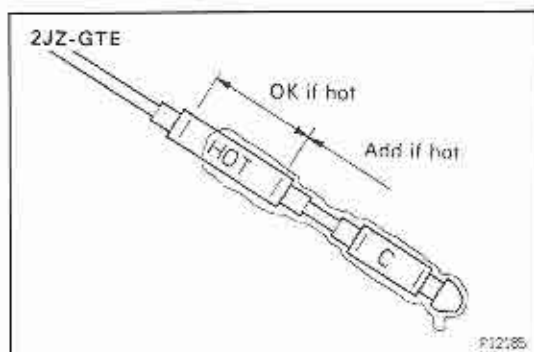

C. Inspect differential oil

- Visually check the differential for fluid and leakage. If leakage is found, check for the cause and repair.
- Remove the filler plug, and feel inside the hole with your finger. Check that the oil comes to within 5 mm (0.20 in.) of the bottom edge of the filler hole. If the level is low, add oil until it begins to run out of the filler hole.

Differential oil: See item 21 (C)

- Reinstall the filler plug securely.

21. REPLACE TRANSMISSION AND DIFFERENTIAL OIL (FLUID)

A. Replace manual transmission oil

- Remove the filler and drain plugs, and drain the oil.
- Reinstall the drain plug securely.
- Add fresh oil until it begins to run out of the filler hole.

Transmission Oil:

2JZ-GE

Oil grade

API GL-5

Viscosity

SAE 75W-90

Capacity:

2.6 liters (2.7 US qts, 2.3 Imp. qts)

2JZ-GTE

Oil:

Castle gear oil V160

Capacity:

1.8 liters (1.9 US qts, 1.6 Imp. qts)

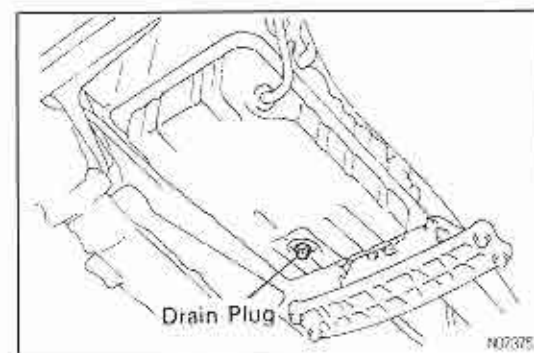
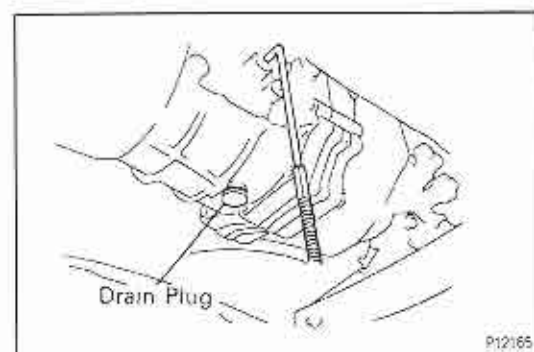

B. Replace automatic transmission fluid

- Remove the drain plug, and drain the fluid.
- Clean the drain plug.
- Reinstall the drain plug securely.

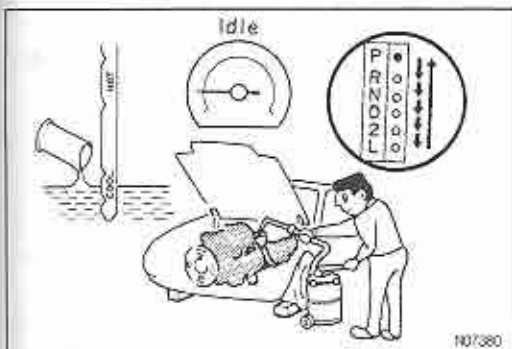

- (d) With the engine "OFF", add new fluid through the dipstick tube.

Transmission fluid:

2JZ-GE

Fluid type

ATF DEXRON® II or equivalent

Drain and refill capacity:

1.6 liters (1.7 US qts, 1.4 Imp.qts)

2JZ-GTE

Fluid type

ATF Type T-II or equivalent Drain and

refill capacity:

1.9 liters (2.0 US qts, 1.7 Imp. qts)

- (e) Start the engine and shift the selector into all positions from "P" through "L", and then shift into "P" position.
- (f) With the engine idling, check the fluid level. Add fluid up the "COOL" range on the dipstick.
- (g) Check that the fluid level is in the "HOT" range at the normal operating temperature (70 – 80 °C (158 – 176 °F)) and add as necessary.
NOTICE: Do not overfill.

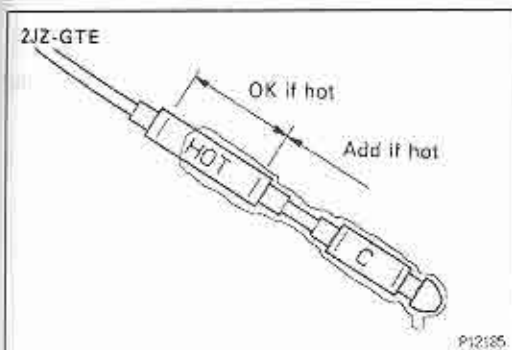
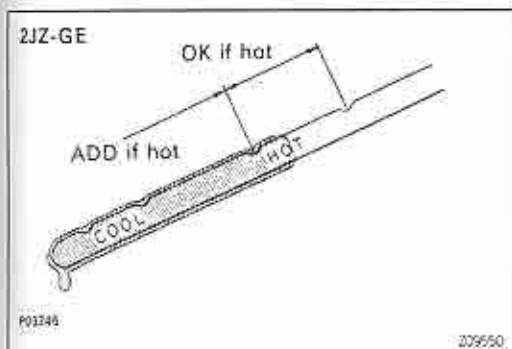

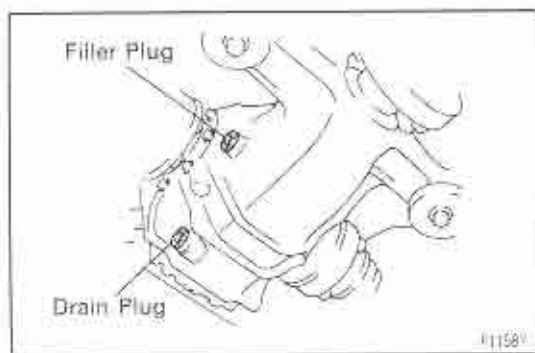

C. Replace differential oil

- Remove the filler and drain plugs, and drain the oil.
- Clean the drain plug.
- Reinstall the drain plug securely.

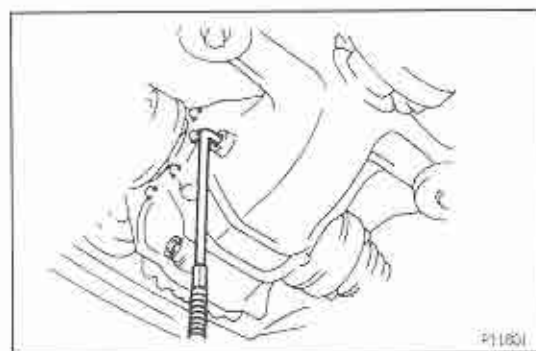

- Add new oil until it begins to run out of the filler hole.

Differential oil:

Oil grade

API GL-5

Viscosity

Above -18°C (0°F) SAE 90

Below -18°C (0°F) SAE 80W-90 or 80W

Capacity:

1.35 liters (1.43 US qts, 1.19 Imp. qts)

- Reinstall the filler plug securely.

22. TIGHTEN BOLTS AND NUTS ON CHASSIS AND BODY

Tighten the following parts:

- Front seat-to-body mounting bolts

Torque: 37 N·m (375 kgf·cm, 27 ft·lbf)



- Front suspension member-to-body mounting bolts

Torque:

Front side

125 N·m (1,280 kgf·cm, 92 ft·lbf)

Front side

200 N·m (2,040 kgf·cm, 148 ft·lbf)

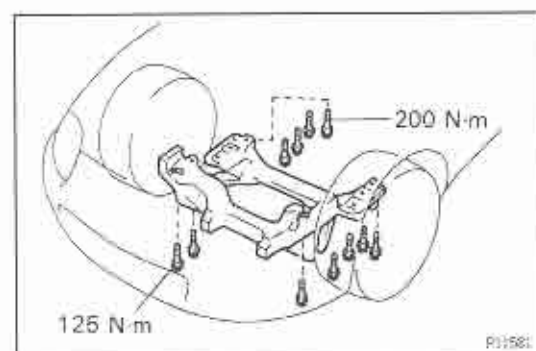

- Rear suspension member-to-body mounting bolts

Torque: 175 N·m (1,790 kgf·cm, 129 ft·lbf)

- Rear suspension member rear cushion-to-body mounting bolts

Torque: 58 N·m (590 kgf·cm, 43 ft·lbf)

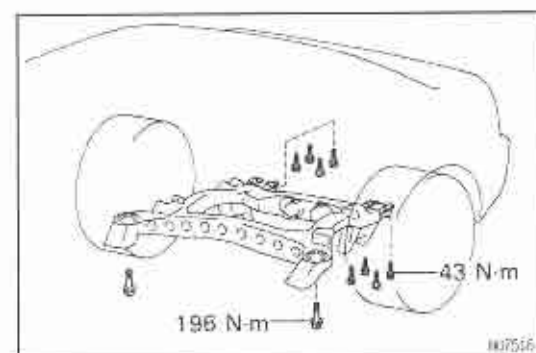

23. BODY INSPECTION

- (a) Check the body exterior for dents, scratches and rust.
- (b) Check the underbody for rust and damage.
If necessary, replace or repair.

24. ROAD TEST

- (a) Check the engine and chassis for abnormal noises.
- (b) Check that the vehicle does not wander or pull to one side.
- (c) Check that the brakes work properly and do not drag.
- (d) Perform setting of the parking brake shoes and drum.

25. FINAL INSPECTION

- (a) Check the operation of the body parts:
 - Hood
Auxiliary catch operates properly
Hood locks securely when closed
 - Front and rear doors
Door locks operate properly
Doors close properly
 - Luggage compartment door
Door lock operates properly
 - Seats
Seat adjusts easily and locks securely in any position
Front seat back locks securely in any position
Folding—down rear seat backs lock securely
- (b) Be sure to deliver a clean car. Especially check:
 - Steering wheel
 - Shift lever knob
 - All switch knobs
 - Seats

GENERAL MAINTENANCE

MAOP-03

There are some maintenance and inspection items which are considered to be the owner's responsibility. They can be performed by the owner or he can have them done at a service shop. These items include those which should be checked on a daily basis, those which, in most cases, do not require (special) tools and those which are considered to be reasonable for the owner to perform. Items and procedures for general maintenance are as follows:

OUTSIDE VEHICLE

MAOP-06

1. TIRES

- (a) Check the pressure with a gauge. Adjust if necessary.
- (b) Check for cuts, damage, uneven or excessive wear.

2. WHEEL NUTS

When checking the tires, check the nuts for looseness or for missing nuts. If necessary, tighten them.

3. WINDSHIELD WIPER BLADES

Check for wear or cracks whenever they do not wipe clean. Replace if necessary.

4. FLUID LEAKS

- (a) Check underneath for leaking fuel, oil, water or other fluid.
- (b) If you smell gasoline fumes or notice any leak, have the cause found and corrected.

5. DOORS AND ENGINE HOOD

- (a) Check that all doors including the trunk lid operate smoothly, and that all latches lock securely.
- (b) Check that the engine hood secondary latch secures the hood from opening when the primary latch is released.

INSIDE VEHICLE

MAOP-08

6. LIGHTS

- (a) Check that the headlights, stop lights, tail-lights, turn signal lights, and other lights are all working.
- (b) Check the headlight aiming.

7. WARNING LIGHT AND BUZZERS

Check that all warning lights and buzzers function properly.

8. HORN

Check that it is working.

9. WINDSHIELD GLASS

Check glass for scratches, pits or abrasions.

10. WINDSHIELD WIPER AND WASHER

- (a) Check operation of the wipers and washer.
- (b) Check that the wipers do not streak.

11. WINDSHIELD DEFROSTER

Check that the air comes out from the defroster outlet when operating the heater air conditioner at defroster mode.

12. REAR VIEW MIRROR

Check that it is mounted securely.

13. SUN VISORS

Check that they move freely and are mounted securely.

14. STEERING WHEEL

Check that it has the specified freeplay. Be alert for changes in steering condition, such as excessive steering effort, excessive freeplay or strange noise.

15. SEATS

- (a) Check that all front seat controls such as seat adjusters, seatback recliner, etc. operate smoothly.
- (b) Check that all latches lock securely in any position.
- (c) Check that the locks hold securely in any latched position.
- (d) Check that the head restraints move up and down smoothly and that the locks hold securely in any latches position.
- (e) For folding-down rear seat backs, check that the latches lock securely.

16. SEAT BELTS

- (a) Check that the seat belt system such as buckles, retractors and anchors operate properly and smoothly.
- (b) Check that the belt webbing is not cut, frayed, worn or damaged.

17. ACCELERATOR PEDAL

Check the pedal for smooth operation and uneven pedal effort or catching.

18. CLUTCH PEDAL

- (a) Check the pedal for smooth operation.
- (b) Check that the pedal has the proper free-play.

19. BRAKE PEDAL

- (a) Check that pedal for smooth operation.
- (b) Check that the pedal has the proper reserve distance and freeplay.
- (c) Check the brake booster function.

20. BRAKES

At a safe place, check that the brakes do not pull to one side when applied.

21. PARKING BRAKE

- (a) Check that the pedal has the proper travel.
- (b) On a safe incline, check that the vehicle is held securely with only the parking brake applied.

22. AUTOMATIC TRANSMISSION PARK MECHANISM

- (a) Check the lock release button of the selector lever for proper and smooth operation.
- (b) On a safe incline, check that the vehicle is held securely with the selector lever in the "P" position and all brakes released.

MA007-04

UNDER HOOD

23. WINDSHIELD WASHER FLUID

Check that there is sufficient fluid in the tank.

24. ENGINE COOLANT LEVEL

Check that the coolant level is between the LEVEL lines on the see-through reservoir at normal temperature (20°C (68°F)).

25. RADIATOR AND HOSES

- (a) Check that the front of the radiator is clean and not blocked with leaves, dirt or bugs.
- (b) Check the hoses for cracks, kinks, rot or loose connections.

26. BATTERY ELECTROLYTE LEVEL

Check the indicator.

When the indicator color is blue, the condition is satisfactory. A red color indicates that distilled water must be added, and white indicates that charging is necessary.

27. BRAKE FLUID LEVEL

Check that the brake fluid level is near the upper level line on the see-through reservoir.

28. ENGINE DRIVE BELT

Check drive belt for fraying, cracks, wear or oil contamination.

29. ENGINE OIL LEVEL

Check that level on the dipstick with the engine turned off.

30. POWER STEERING FLUID LEVEL

Check the level on the dipstick. The level should be in the "HOT" or "COLD" range depending on the fluid temperature.

31. AUTOMATIC TRANSMISSION FLUID LEVEL

- (a) Park the vehicle on a level surface.
- (b) With the engine idling and the parking and foot brake applied, shift the selector into all positions from "P" to "L", and then shift into "P" position.
- (c) Turn and pull out the dipstick and wipe off the fluid with a clean rag.

Re-insert the dipstick fully and check that the fluid level is in the "HOT" range.

- (d) Perform this check with the fluid at normal driving temperature (70 — 80°C (158 — 176°F)).

If the level is at the low side, add fluid.

NOTICE: Do not overfill.

HINT: Wait about 30 minutes before checking the fluid level after extended driving at high speeds in hot weather, driving in heavy traffic or with a trailer.

32. EXHAUST SYSTEM

Visually inspect for cracks, holes or loose supports.

If any change in the sound of the exhaust or smell of the exhaust fumes is noticed, have the cause located and corrected.

SERVICE SPECIFICATIONS

SERVICE DATA

MA02-01

Engine	Spark plug			
	Recommended spark plug	ND for 2JZ-GE for 2JZ-GTE NGK for 2JZ-GE for 2JZ-GTE	PK16R11 PK20R11 BKR6EP11 BKR6EP11	
	Correct electrode gap			1.1 mm (0.043 in.)
	Firing order			1 - 5 - 3 - 6 - 2 - 4
	Valve clearance	Intake Exhaust		0.15 - 0.25 mm (0.006 - 0.010 in.) 0.25 - 0.35 mm (0.010 - 0.014 in.)
Brake	Front and rear brakes			
	Pad thickness	Limit		1.0 mm (0.039 in.)
	Disc thickness	Limit (Front for 2JZ-GE) (Front for 2JZ-GTE) (Rear)		30.0 mm (1.181 in.)
				28.0 mm (1.102 in.)
				15.0 mm (0.591 in.)
	Disc runout	Limit		0.05 mm (0.0020 in.)
	Parking brake			
Lining thickness	Limit		1.0 mm (0.039 in.)	
	Drum inside diameter	Limit		191 mm (7.520 in.)
Chassis	Steering linkage			
	Steering wheel freeplay	Limit		30 mm (1.18 in.)
	Ball joint			
	Vertical play	Limit		0.3 mm (0.012 in.)

MA02-01

TORQUE SPECIFICATIONS

Part tightened		N-m	kgf-cm	ft-lbf
Spark plug x Cylinder head		18	180	13
Front seat x Body		37	375	27
Front suspension member x Body	Front side	125	1,280	92
	Rear side	200	2,040	148
Rear suspension member x Body		175	1,790	129
Rear suspension member rear cushion x Body		58	590	43