

# DRIVE AXLES

1996 Toyota Supra

1995-96 DRIVE AXLES  
Toyota - RWD Axle Shafts

Supra

## \* PLEASE READ THIS FIRST \*

NOTE: Information in this article applies only to models with independent rear suspension. For other models, see DIFFERENTIALS & AXLE SHAFTS article in DRIVE AXLES section.

## DESCRIPTION & OPERATION

Axle shafts transfer power from differential or transaxle to driving wheels. Axle shaft consists of axle shaft and flexible Constant Velocity (CV) joint at each end. Inner (inboard) CV joint is bolted or splined to differential or transaxle. Outer (outboard) CV joint is splined to rear hub assembly and secured by axle shaft nut.

Inner and outer CV joints are enclosed by a CV joint boot. Boot maintains lubrication in CV joint and prevents contamination of CV lubricant. Boots must be replaced if cracked, torn or damaged. Inner CV joint can be repaired. Outer CV joint must be replaced as an assembly.

## TROUBLE SHOOTING

NOTE: See TROUBLE SHOOTING - BASIC PROCEDURES article in GENERAL INFORMATION.

## REMOVAL, DISASSEMBLY, REASSEMBLY & INSTALLATION

### AXLE SHAFTS

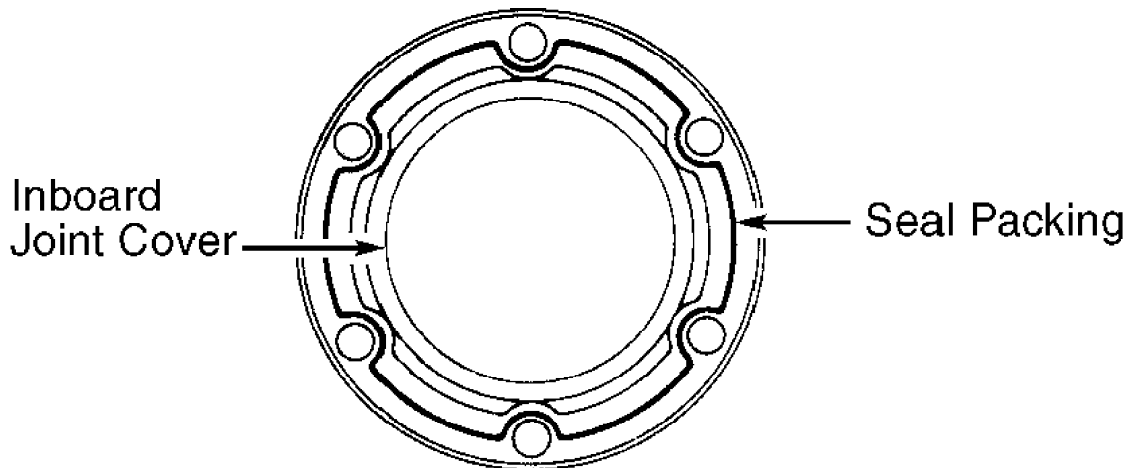

94B47671

Fig. 1: Applying Seal Packing On Inboard Joint Cover  
Courtesy of Toyota Motor Sales, U.S.A., Inc.

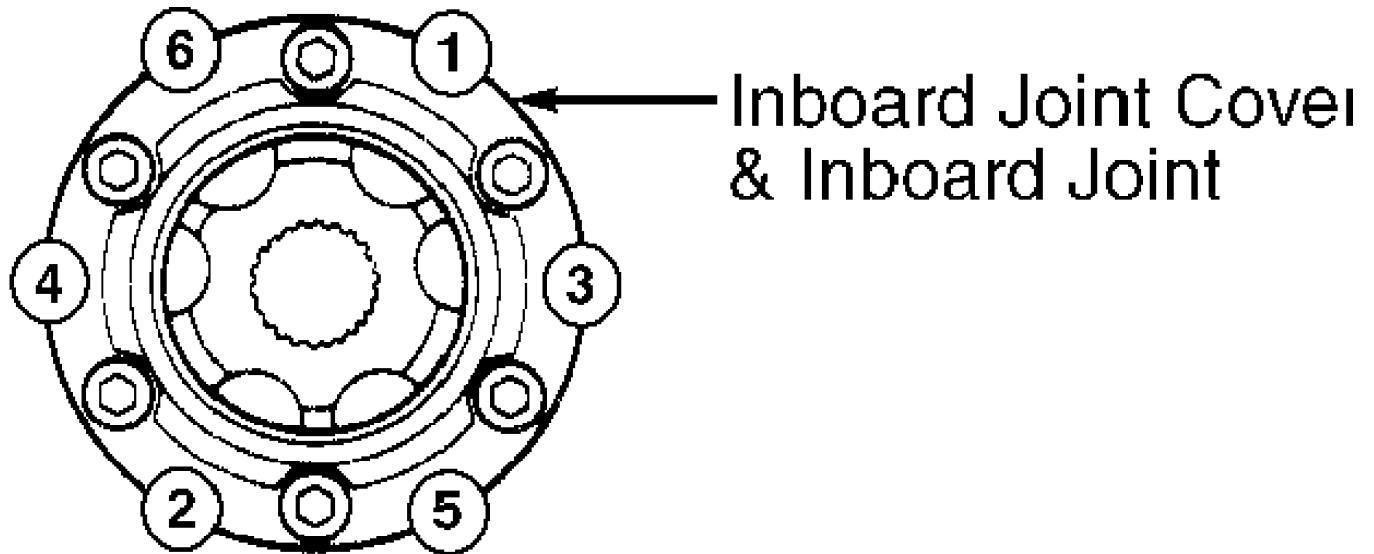

## 94C47672

Fig. 2: Inboard Joint & Inboard Joint Cover Installation Sequence  
 Courtesy of Toyota Motor Sales, U.S.A., Inc.

### Removal

- 1) Raise and support vehicle. Remove rear wheels. Support tailpipe with muffler assembly and remove rubber hangers.
- 2) Remove cotter pin and lock cap from end of axle shaft. Apply brakes and remove axle shaft nut. Release brakes. Remove bolts and lower suspension arm brace, located below axle shaft. See Fig. 3.
- 3) Paint reference marks on inboard axle shaft flange and differential side gear flange for reassembly reference. Apply brakes. Remove axle shaft-to-differential side gear flange bolts and washers. Release brakes.
- 4) Disconnect inboard axle shaft flange from differential side gear flange. Using plastic hammer, tap axle shaft from rear hub assembly. Remove axle shaft assembly.

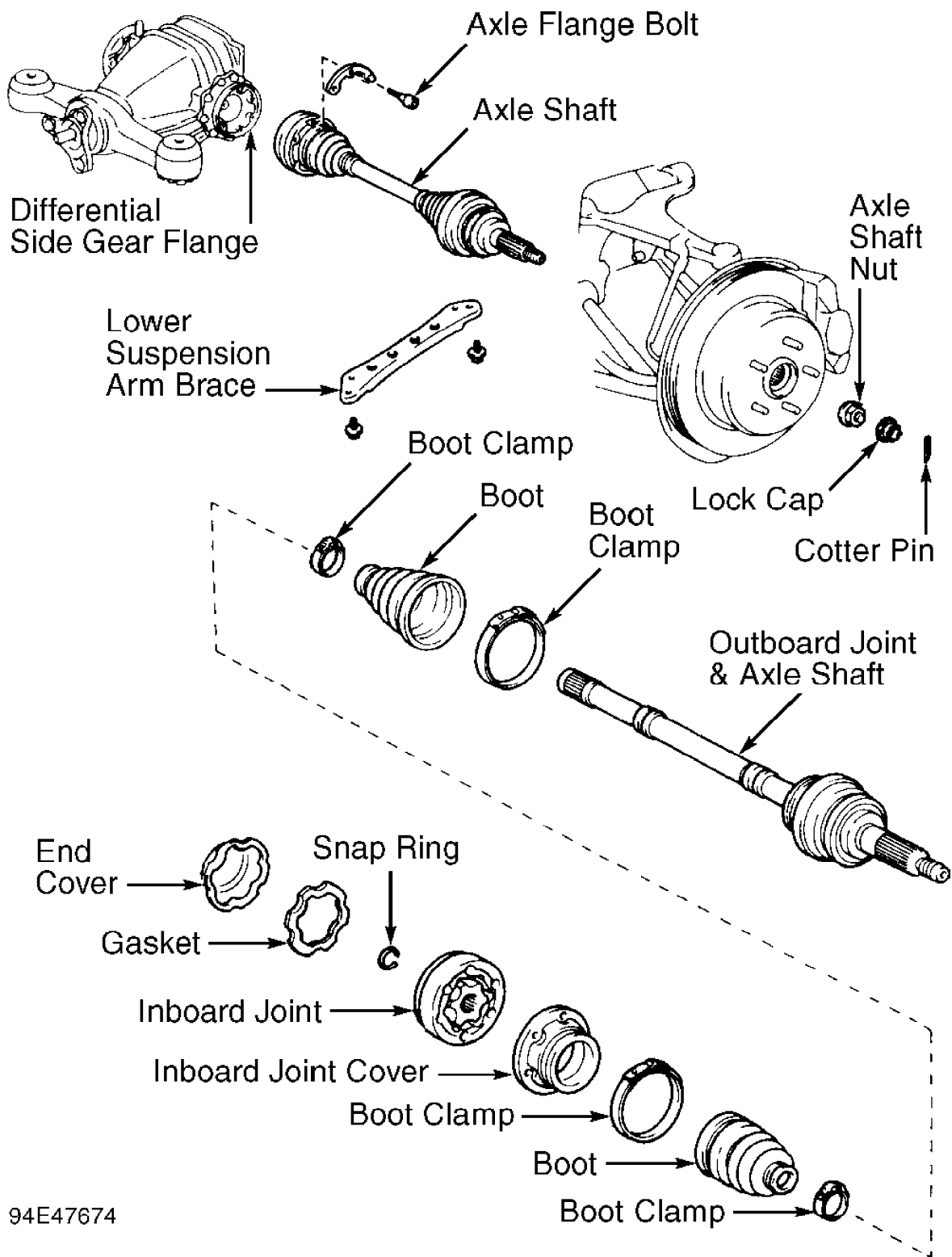

94E47674

Fig. 3: Identifying Axle Shaft Components  
 Courtesy of Toyota Motor Sales, U.S.A., Inc.

Inspection  
 Ensure no play exists in inboard and outboard joints. Ensure

inboard and outboard joints slide smoothly inward and outward. Check for torn or damaged boots. Check ABS sensor rotor for damage.

#### Disassembly

1) Remove end cover. Install bolts and washers on inboard joint to hold inboard joint assembly together. Remove boot clamps from all boots. Place reference mark on axle shaft and inboard joint for reassembly reference. DO NOT use punch to make reference marks.

2) Remove snap ring from axle shaft, at center of inboard joint. Using press, press inboard joint from axle shaft. Mount inboard joint in soft-jawed vise with inboard joint cover facing upward.

3) Using hammer and screwdriver, tap inboard joint cover from inboard joint. Ensure cage and inner race on inboard joint are not positioned too much to one side of outer race. DO NOT remove balls, inner cage and outer cage from inboard joint. Remove inboard and outboard boots.

NOTE: Manufacturer does not recommend overhaul of outboard joint assembly.

#### Reassembly

1) If joint has come apart, align matchmarks placed before removal. If matchmarks have disappeared, install inner race to cage so that indented bevelled part of inner race is on opposite side to bevelled top of cage.

2) Install outer race so that indented side of outer race is facing same side as bevelled surface of cage. Match narrow projections of inner race with side projections of outer race. Tilt cage and inner race to side and insert balls one at a time. Support joint with your hand to prevent balls from falling out.

3) Wrap splines on axle shaft with tape to prevent damage to boots during installation. Install NEW boots and NEW boot clamps on axle shaft.

4) If joint has not come apart, temporarily install NEW boots and NEW boot clamps. Apply seal packing on inboard joint cover. See Fig. 1. Install inboard joint cover on inboard joint so all bolt holes are aligned.

5) Using hammer and brass drift, tap on inboard joint cover in sequence shown several times to install inboard joint cover on inboard joint. See Fig. 2.

6) Repeat procedure several times to ensure inboard joint cover and inboard joint are properly engaged. Install bolts, washers and nuts on inboard joint cover and inboard joint to hold assembly together.

7) Install inboard joint on axle shaft with reference mark aligned. Using hammer and brass drift, drive on inner race until inboard joint is fully seated on axle shaft. DO NOT allow brass drift to contact cage on inboard joint subassembly during installation.

8) Install NEW snap ring on end of axle shaft. Pack 3.5-3.7 ounces of grease supplied with overhaul kit in each boot for inboard and outboard joints. Install boots in proper location.

9) Adjust axle shaft length to specification. See AXLE SHAFT LENGTH SPECIFICATIONS table. See Fig. 4. Using Clamp Tightener (SST 09512-24010), tighten boot clamps until clamp opening clearance at ends of boot clamps is .031" (.80 mm) or less.

10) Ensure all grease is removed from inside of end cover. Pack grease into center of gasket on end cover. Glue NEW gasket on end cover with adhesive side of gasket facing outer race on inboard joint.

11) Align bolt holes and install end cover. Install bolts/nuts and tighten in a crisscross pattern to install end cover on inboard joint. Ensure claw on end cover contacts inboard joint and all joints move smoothly.

AXLE SHAFT LENGTH SPECIFICATIONS TABLE

| Application          |     | In. (mm)                  |
|----------------------|-----|---------------------------|
| Turbo                |     |                           |
| A/T                  |     |                           |
| Right Axle Shaft     | (1) | 22.78-24.35 (578.5-618.5) |
| Left Axle Shaft      | (1) | 21.00-22.58 (533.5-573.5) |
| M/T                  |     |                           |
| Right Axle Shaft     | (1) | 22.78-24.35 (578.5-618.5) |
| Left Axle Shaft      | (1) | 20.76-22.34 (527.5-567.5) |
| Non Turbo, A/T & M/T |     |                           |
| Right Axle Shaft     | (1) | 22.78-24.35 (578.5-618.5) |
| Left Axle Shaft      | (1) | 21.00-22.58 (533.5-573.5) |

(1) - Measure axle shaft length from outboard joint flange to end of inboard joint. See Fig. 4.

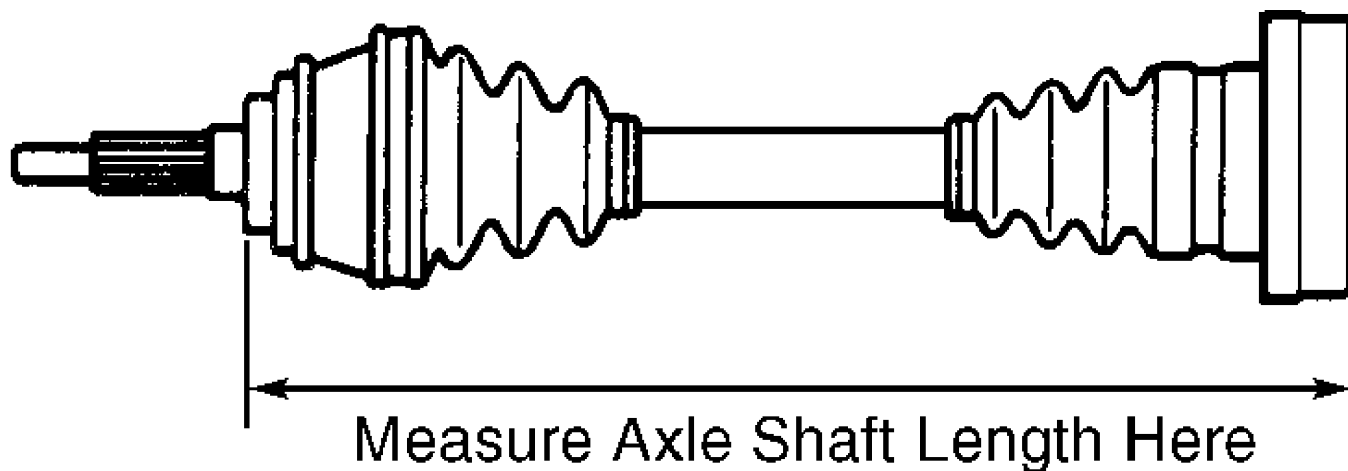

**94F47675**

Fig. 4: Measuring Axle Shaft Length  
 Courtesy of Toyota Motor Sales, U.S.A., Inc.

Installation

1) To install, reverse removal procedure. Ensure reference marks on inboard axle shaft flange and differential side gear flange are aligned. Ensure ABS speed sensor signal is present. See BRAKE SYSTEM - ANTI-LOCK article in BRAKES section.

2) Apply engine oil on threads of axle shaft-to-differential side gear flange bolts before installing. Tighten bolts/nuts to specification. See TORQUE SPECIFICATIONS.

**REAR HUB ASSEMBLY**

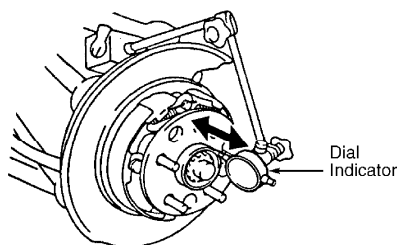

**94G47676**  
 Fig. 5: Checking Bearing End Play  
 Courtesy of Toyota Motor Sales, U.S.A., Inc.

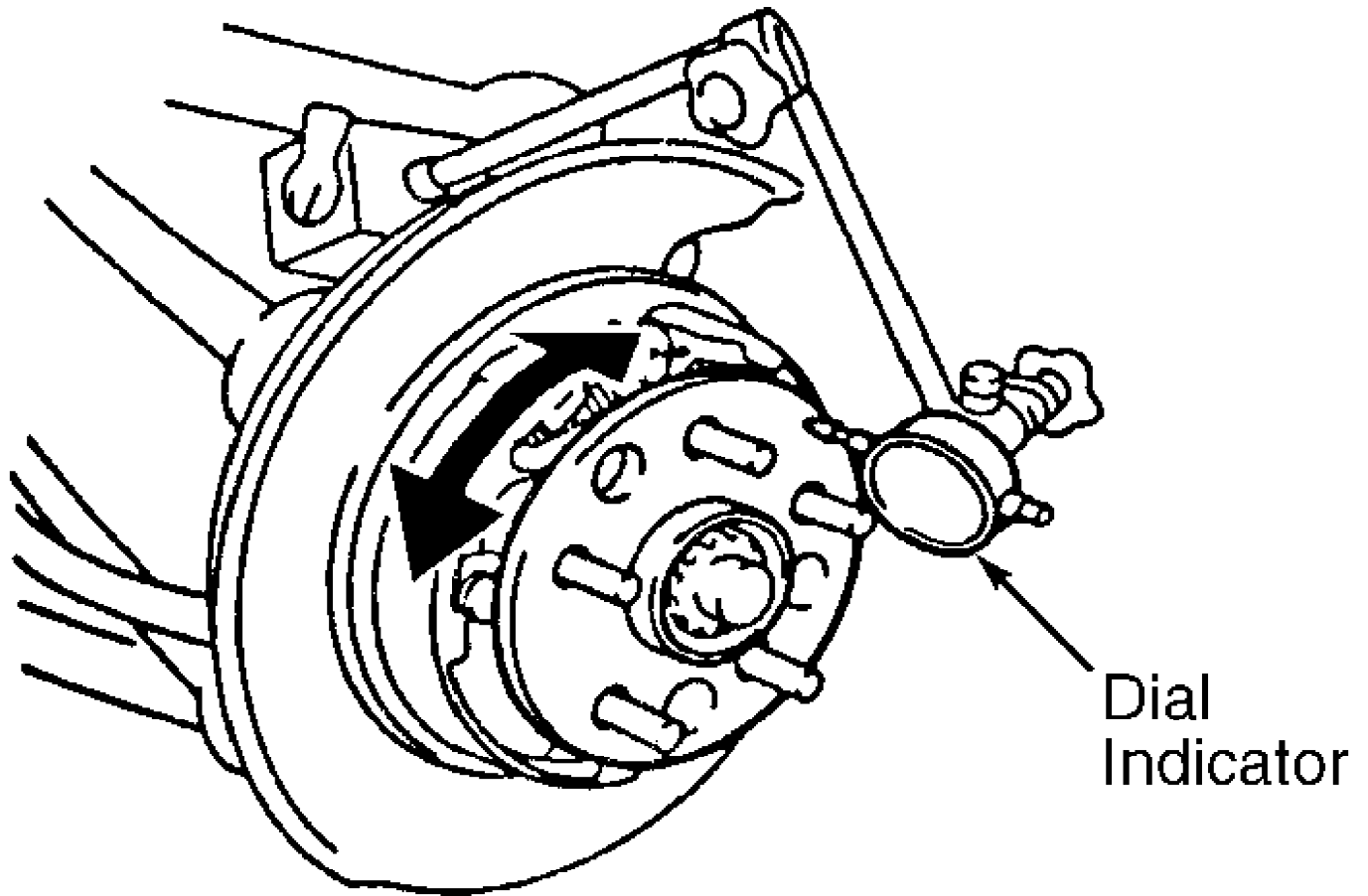

**94H47677**

Fig. 6: Checking Rear Hub Runout  
 Courtesy of Toyota Motor Sales, U.S.A., Inc.

Removal

1) Raise and support vehicle. Remove rear wheel. Remove brake caliper with hose attached and secure aside. Place reference mark on brake rotor and rear hub assembly for reassembly reference. Remove brake rotor.

2) Using dial indicator, check bearing end play while moving rear hub inward and outward. See Fig. 5. Replace bearing if bearing end play exceeds .002" (.05 mm).

3) Using dial indicator, check rear hub runout while rotating rear hub. See Fig. 6. Replace rear hub if runout exceeds .002" (.05 mm).

4) Remove rear axle shaft. See AXLE SHAFT article in DRIVE AXLES section. Remove bolt and pull ABS speed sensor from rear of axle carrier.

5) Remove parking brake shoe assembly from backing plate. Disconnect necessary parking brake cable brackets. Remove strut rod, located between lower end of rear axle carrier and body. See Fig. 7.

6) Place reference marks on adjusting cam and subframe for reassembly reference. Remove adjusting cam and separate lower suspension arm No. 1 from subframe. Lower suspension arm No. 1 is located between subframe and front of rear axle carrier.

7) Disconnect shock absorber and stabilizer bar link from lower suspension arm No. 2. Remove nut and disconnect ball joint on

lower suspension arm No. 2 from axle carrier.

8) Remove nut and separate ball joint on upper suspension arm from axle carrier. Remove axle carrier. Remove nut and separate lower suspension No. 1 from axle carrier.

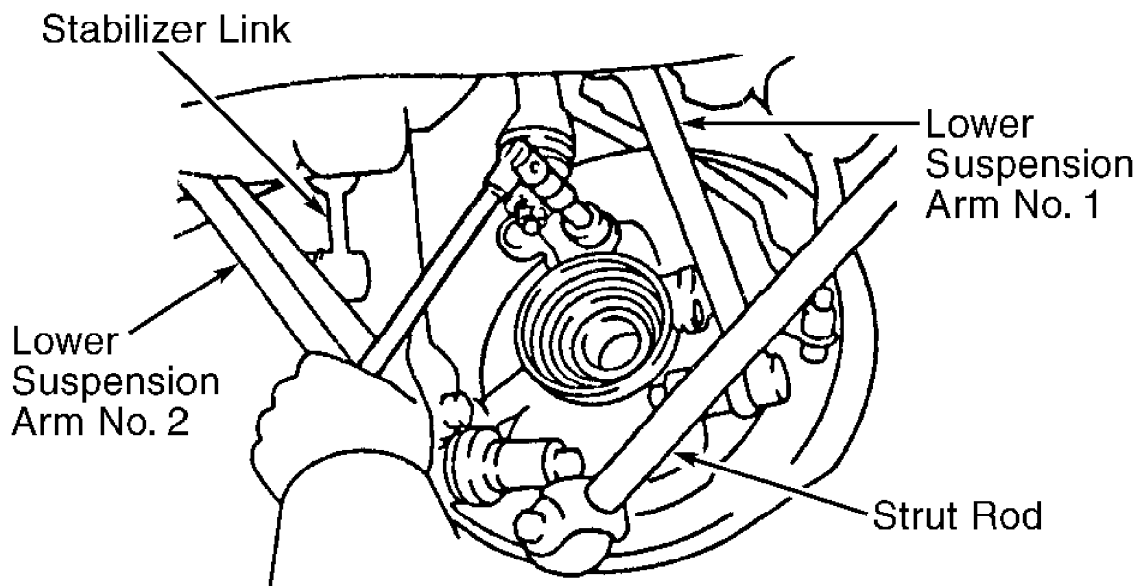
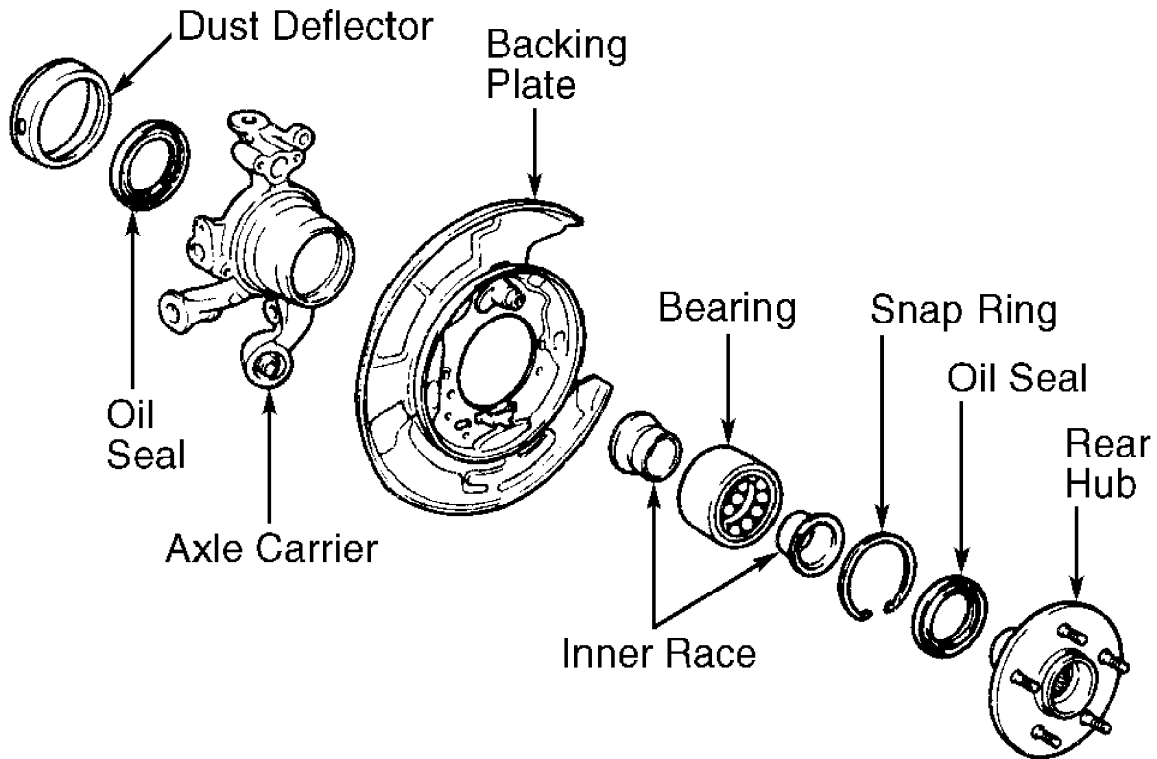

94J47679

Fig. 7: Exploded View Of Rear Hub Assembly & Components  
Courtesy of Toyota Motor Sales U.S.A., Inc.

Disassembly

- 1) Secure axle carrier in a soft-jawed vise. Remove dust

deflector. Using slide hammer puller, remove rear hub from axle carrier. Remove backing plate.

2) Using press and bearing splitter, press inner bearing race from backside of rear hub. Remove oil seals from axle carrier. Remove snap ring from front of axle carrier. Place inner bearing race on bearing in axle carrier. Using press, press bearing from axle carrier.

#### Reassembly

1) Using press, press NEW bearing with inner race into axle carrier. Install snap ring. Install NEW oil seal on front of axle carrier until surface of oil seal is even with surface of axle carrier.

2) Coat lip of oil seal with grease. Temporarily install backing plate. Install remaining inner race on bearing. Using press, press rear hub into bearing. Install remaining NEW oil seal on rear of axle carrier.

3) Coat lip of oil seal with grease. Install NEW dust deflector on axle carrier. Ensure hole for ABS speed sensor aligns with hole on axle carrier. Using press, press dust deflector on axle carrier.

#### Installation

1) Install upper suspension arm and lower suspension arm No. 2 on axle carrier using NEW nut. Tighten nuts to specification. See TORQUE SPECIFICATIONS.

2) Install shock absorber on lower suspension arm No. 2 with bolt/nut loosely installed. DO NOT tighten bolt/nut at this time. Install stabilizer bar link on lower suspension arm No. 2 and tighten nut to specification.

3) Install adjusting cam and lower suspension arm No. 1 on subframe. Ensure reference mark on adjusting cam and subframe are aligned. Install and loosely install nut on adjusting cam. DO NOT tighten nut at this time.

4) Using NEW nut, install lower suspension arm No. 1 on axle carrier. Tighten nut to specification. See TORQUE SPECIFICATIONS.

5) Install strut rod with bolt/nuts loosely installed. DO NOT tighten bolts/nuts at this time. Install parking brake assembly. Ensure ABS speed sensor is clean. Install ABS speed sensor on axle carrier. Install and tighten bolt to specification. See TORQUE SPECIFICATIONS.

6) Install rear axle shaft. Install brake rotor. Ensure reference marks on brake rotor and rear hub assembly are aligned. Install brake caliper. Install and tighten bolts to specification.

7) Install rear wheel. Tighten wheel lug nuts to specification. Lower vehicle. Bounce vehicle up and down several times to stabilize suspension components. Raise and support vehicle.

8) Remove rear wheel. Support rear differential with floor jack. Ensure reference mark on adjusting cam and subframe are aligned. Tighten adjusting cam nut, strut rod bolts/nuts and shock absorber-to-lower suspension arm No. 2 bolt/nut to specification. See TORQUE SPECIFICATIONS.

9) Reinstall rear wheel. Tighten wheel lug nuts to specification. Check rear wheel alignment.

## TORQUE SPECIFICATIONS

### TORQUE SPECIFICATIONS TABLE

| Application           | Ft. Lbs. (N.m) |
|-----------------------|----------------|
| ABS Speed Sensor Bolt | (1)            |
| Adjusting Cam Nut (2) | 136 (184)      |

|  |           |
|--|-----------|
| Axle Shaft Nut .....                             | 213 (289) |
| Axle Shaft-To-Differential Side Gear Flange Bolt |           |
| Turbo .....                                      | 61 (83)   |
| Non Turbo .....                                  | 48 (65)   |
| Backing Plate-To-Axle Carrier Bolt .....         | 19 (26)   |
| Brake Caliper Bolt .....                         | 77 (104)  |
| Lower Suspension Arm Brace Bolt .....            | 13 (18)   |
| Lower Suspension Arm No. 1-To-Axle               |           |
| Carrier Nut .....                                | 43 (58)   |
| Lower Suspension Arm No. 2-To-Axle               |           |
| Carrier Nut .....                                | 110 (149) |
| Shock Absorber-To-Lower Suspension               |           |
| Arm No. 2 Bolt/Nut (2) .....                     | 101 (137) |
| Stabilizer Bar Link-To-Lower Suspension          |           |
| Arm No. 2 Nut .....                              | 54 (73)   |
| Strut Rod Bolt/Nut (2) .....                     | 136 (184) |
| Upper Suspension Arm-To-Axle Carrier Nut .....   | 80 (109)  |
| Wheel Lug Nut .....                              | 76 (103)  |

- (1) - Tighten bolt to 71 INCH lbs. (8.0 N.m).
  - (2) - Tighten bolt/nut to specification after vehicle is lowered to ground and bounced several times to stabilize suspension components and vehicle is raised and rear differential is supported with floor jack.
-