

# DIFFERENTIAL & AXLE SHAFTS - INTEGRAL HOUSING

## 1996 Toyota Supra

1995-96 DRIVE AXLES  
Toyota - Differentials & Axle Shafts Integral Housing  
Supra

### DESCRIPTION & OPERATION

Drive axle assembly is a hypoid gear-type with integral housing. Drive pinion transfers power to the ring gear which provides power to the side gear shafts. Side gear shafts are connected to the axle shafts which transfer the power to the wheels. Drive pinion preload is adjusted using collapsible spacer. Side bearing preload is adjusted using plate washers.

Rear differential may be a Limited Slip Differential (LSD) or a conventional type rear differential. If equipped with LSD, manufacturer does not recommend disassembly of differential case.

### AXLE RATIO & IDENTIFICATION

Axle ratio may be determined by dividing number of ring gear teeth by number of teeth on drive pinion.

AXLE RATIO SPECIFICATIONS TABLE

Application	Ratio
Non-Turbo .....	4.272:1
Turbo	
A/T .....	3.769:1
M/T .....	3.133:1

### LUBRICATION

#### CAPACITY

DIFFERENTIAL FLUID CAPACITY TABLE

Application	(1) Quantity
Supra .....	1.4 Qts. (1.3L)

(1) - Approximate quantity listed.

#### FLUID TYPE

FLUID TYPE SPECIFICATIONS TABLE

Application	Fluid Type
Temperature	
Greater Than 0°F (-18°C) .....	SAE 90W GL-5 Hypoid Gear Oil
Less Than 0°F (-18°C) .....	SAE 80W-90 GL-5 Hypoid Gear Oil

## **TROUBLE SHOOTING**

NOTE: See TROUBLE SHOOTING - BASIC PROCEDURES article in GENERAL INFORMATION.

## **REMOVAL & INSTALLATION**

NOTE: For rear axle shaft servicing procedures, see AXLE SHAFTS - RWD article in DRIVE AXLES section.

### **DRIVE SHAFT**

#### Removal

1) Raise and support vehicle. Disconnect electrical connector from oxygen sensor mounted in exhaust pipe. Disconnect exhaust pipe at exhaust manifold and support bracket. Remove exhaust pipe with mufflers and tailpipe.

2) Remove heat insulator mounted on body, below drive shaft. Remove crossmember brace located below drive shaft. Place reference mark on drive shaft companion flange and companion flange on differential for reassembly reference.

3) Remove drive shaft companion flange bolts at companion flange on differential. DO NOT remove bolts that secure companion flange to drive shaft.

4) On turbo models, place reference mark on drive shaft companion flange and companion flange at transmission. Remove drive shaft-to-transmission companion flange nuts.

5) On all models, support drive shaft. Remove drive shaft center bearing bolts. Remove adjusting washers located between drive shaft center bearing and body (if equipped).

6) Slide drive shaft forward to clear shaft on drive pinion at center of companion flange on differential. On non-turbo models, pull drive shaft from transmission. On all models, remove drive shaft.

#### Installation

1) To install, reverse removal procedure. Before installing drive shaft, apply grease on bushing located in end of companion flange on drive shaft at differential end of drive shaft.

2) Ensure reference marks are aligned. Ensure bracket on drive shaft center bearing is perpendicular to drive shaft before tightening bolts. Tighten bolt/nuts to specification. See TORQUE SPECIFICATIONS.

### **SIDE GEAR SHAFT & OIL SEAL**

#### Removal

1) Drain differential gear oil. Manufacturer recommends removal of axle shaft for servicing of oil seal. Remove axle shaft. See AXLE SHAFTS - RWD article in DRIVE AXLES section. Using slide hammer, pull side gear shaft from differential carrier. See Fig. 1 or 2.

2) Note depth of oil seal installation in differential carrier retainer. Remove oil seal from differential carrier retainer.

#### Installation

1) Install NEW oil seal in differential carrier retainer until oil seal is at original depth on differential carrier retainer.

2) Install NEW snap ring on end of side gear shaft. Coat snap ring with grease. Using hammer and brass drift, drive side gear shaft into differential carrier. Ensure side gear shaft cannot be pulled from differential carrier. To install remaining components, reverse

removal procedure. Fill differential with gear oil.

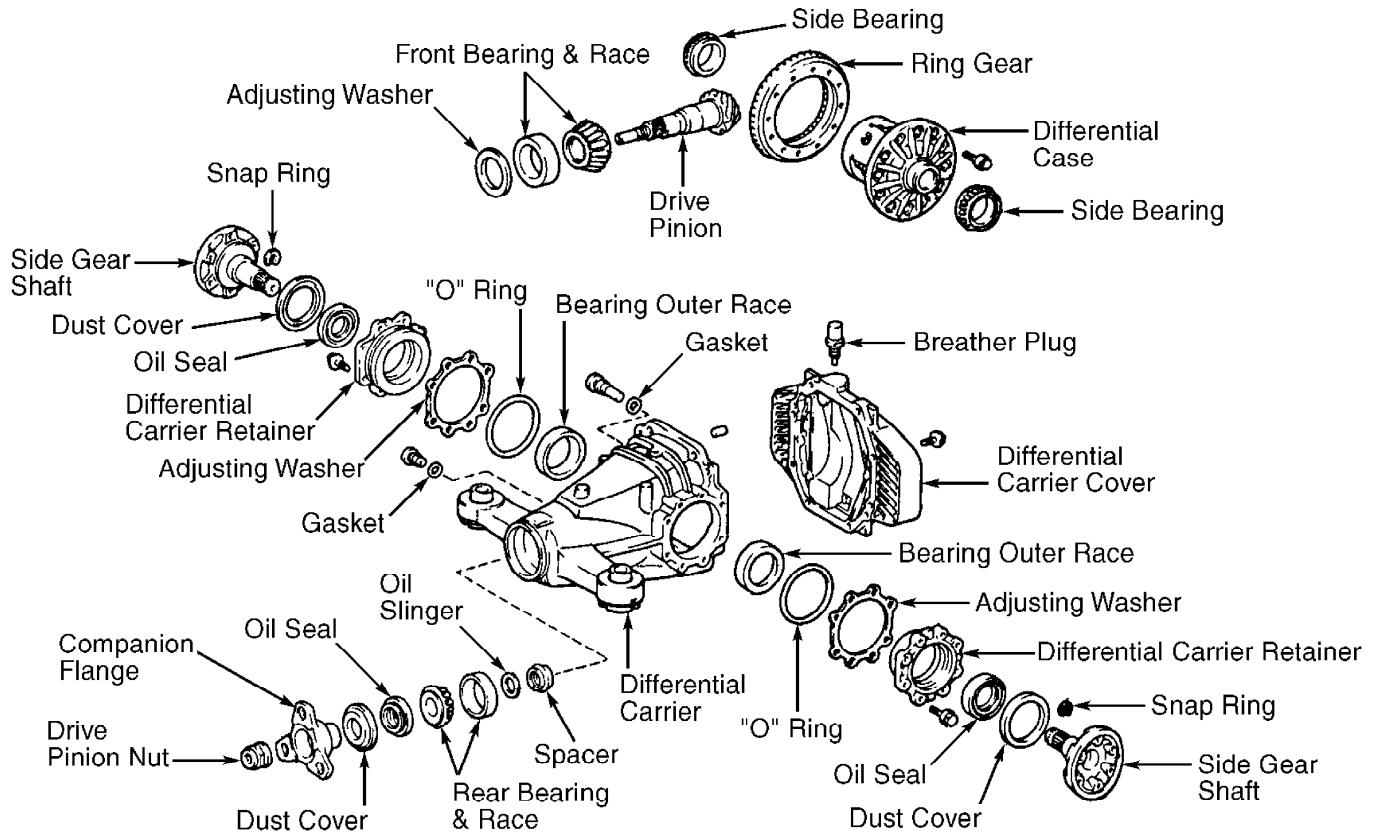

94G47833

Fig. 1: Exploded View Of Rear Differential Assembly Turbo With M/T  
 Courtesy of Toyota Motor Sales, U.S.A., Inc.

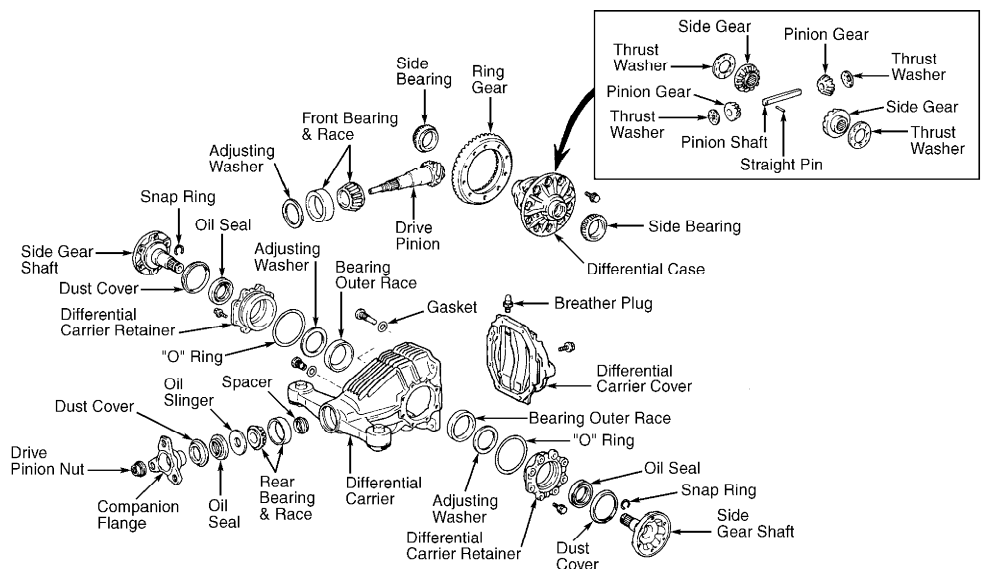

94H47834

Fig. 2: Exploded View Of Rear Differential Assembly All Others  
 Courtesy of Toyota Motor Sales, U.S.A., Inc.

**PINION FLANGE & OIL SEAL**

### Removal & Installation

Manufacturer does not provide on-vehicle information for servicing of pinion flange and oil seal.

## DIFFERENTIAL ASSEMBLY

### Removal

1) Remove drive shaft. See DRIVE SHAFT. Drain differential gear oil. Place reference mark on axle shaft flange-to-side gear shaft on differential for reassembly reference. Remove axle shaft flange-to-side gear shaft bolts. Separate axle shaft from side gear shaft and wire aside..

2) Disconnect stabilizer bar link from lower suspension arm. Remove stabilizer bar mounting bracket bolts and remove stabilizer bar.

3) Support differential assembly with transmission jack. Remove differential assembly mounting bolts and insulators. Note location of insulators for reassembly reference. Insulators must be installed in original location during installation. Remove differential assembly.

**NOTE:** Some models may contain adjusting washers located on top side of insulators at front of differential assembly. Ensure adjusting washers (if equipped) are installed in original location when installing differential assembly.

### Installation

To install, reverse removal procedure. Use NEW bolts when installing differential assembly. Ensure reference marks are aligned. Tighten bolts/nuts to specification. See TORQUE SPECIFICATIONS. Fill differential assembly with gear oil.

## OVERHAUL

### DIFFERENTIAL ASSEMBLY

#### Disassembly

1) Using dial indicator, check drive pinion shaft runout at 10 o'clock position at .39" (10.0 mm) from end of shaft on drive pinion. See Fig. 3. Replace drive pinion and ring gear if drive pinion shaft runout exceeds .0031" (.080 mm).

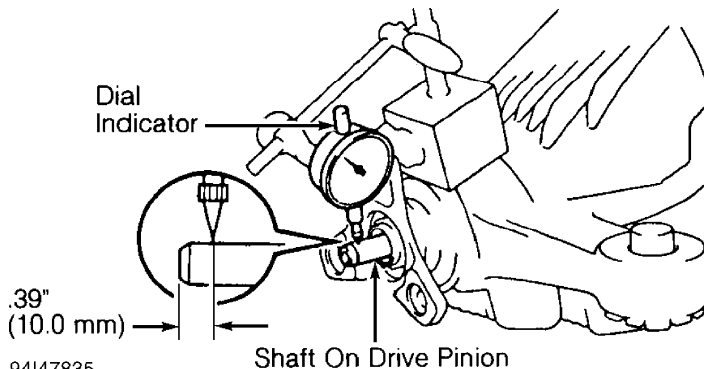

94147835  
Fig. 3: Checking Drive Pinion Shaft Runout  
Courtesy of Toyota Motor Sales, U.S.A., Inc.

2) Using INCH-lb. torque wrench installed on drive pinion nut, measure drive pinion rotating torque required to start rotation

of drive pinion. This will determine drive pinion bearing preload for reassembly reference. Drive pinion rotating torque should be within specification. See AXLE ASSEMBLY SPECIFICATIONS table.

3) Using INCH-lb. torque wrench installed on drive pinion nut, measure total assembled preload required to rotate drive pinion and ring gear for reassembly reference. Total assembled preload should be within specification. See AXLE ASSEMBLY SPECIFICATIONS table.

4) Remove differential carrier cover. Using dial indicator, check ring gear runout at backside of ring gear while rotating ring gear. See Fig. 4. Replace ring gear and drive pinion as a set if ring gear runout exceeds specification. See AXLE ASSEMBLY SPECIFICATIONS table.

5) Using dial indicator, check ring gear backlash while rotating ring gear back and forth while holding drive pinion from rotating. See Fig. 4. Check ring gear backlash at 3 different areas on ring gear. Ring gear backlash should be within specification. See AXLE ASSEMBLY SPECIFICATIONS table. Ring gear backlash should not vary more than .002" (.05 mm) between lowest reading and highest reading.

NOTE: On models with Limited Slip Differential (LSD), side gear backlash cannot be checked.

6) On conventional type differentials, use dial indicator to check side gear backlash while holding one side gear against differential case. See Fig. 4. Side gear backlash should be within specification. See AXLE ASSEMBLY SPECIFICATIONS table. If side gear backlash is not within specification, different thickness thrust washers must be installed on side gears.

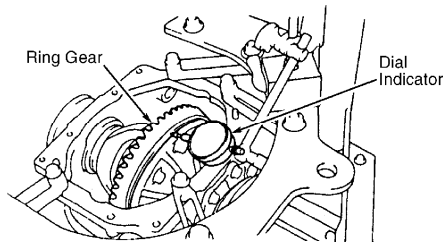

CHECKING RING GEAR RUNOUT

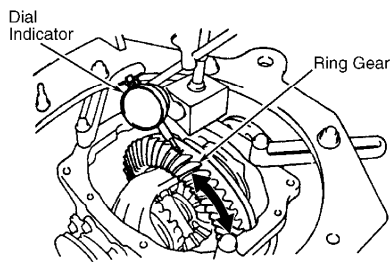

CHECKING RING GEAR BACKLASH

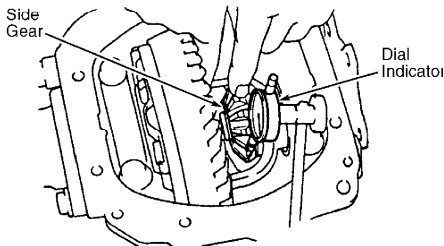

CHECKING SIDE GEAR BACKLASH

94J47836  
Fig. 4: Checking Typical Ring Gear Runout, Ring Gear Backlash & Side Gear Backlash

Courtesy of Toyota Motor Sales, U.S.A., Inc.

7) On all differentials check gear tooth contact pattern. See GEAR TOOTH CONTACT PATTERNS article in GENERAL INFORMATION.

8) Remove side gear shafts and oil seals. See SIDE GEAR SHAFT & OIL SEAL under REMOVAL & INSTALLATION. Remove bolts from each differential carrier retainer. See Fig. 1 or 2.

NOTE: On turbo models with M/T, adjusting washer is located on outside of differential carrier retainer. On all others, adjusting washer is located in differential carrier retainer, below bearing outer race. See Fig. 1 or 2.

9) On turbo models with M/T, use puller to remove differential carrier retainer (with bearing outer race and adjusting washer) from each side of differential carrier.

10) On all others, use screwdriver on each side of differential carrier retainer to pry differential carrier retainer (with bearing outer race and adjusting washer) from each side of differential carrier. On all models, remove bearing outer race, adjusting washer and "O" ring from differential carrier retainer (if necessary). See Fig. 1 or 2.

11) Remove differential case and ring gear from differential carrier. Using hammer and chisel, loosen stake area on drive pinion nut. Remove drive pinion nut. Using press, press drive pinion with front bearing and spacer from differential carrier and companion flange.

12) Remove companion flange and oil seal from differential carrier. On turbo models with M/T, remove oil slinger from drive pinion. On all others, remove oil slinger from front bearing. On all models, remove spacer from drive pinion. Remove rear bearing from differential carrier.

13) Press front bearing from drive pinion (if necessary). Using hammer and brass drift, remove bearing races from differential carrier. Remove and record thickness of adjusting washer located between front bearing race and differential carrier. See Fig. 3.

14) Using puller, remove side bearings from differential case (if necessary). If removing ring gear from differential case, place reference mark on ring gear and differential case for reassembly reference. Remove ring gear bolts. Using soft-faced hammer, tap ring gear from differential case.

NOTE: On models with Limited Slip Differential (LSD), manufacturer does not recommend disassembly of differential case.

15) On conventional type drive axles if side gear backlash was not checked previously, install side gear shaft in one side gear. Using dial indicator, check side gear backlash while holding one side gear against differential carrier. See Fig. 4.

16) Side gear backlash should be within specification. See AXLE ASSEMBLY SPECIFICATIONS table. If side gear backlash is not within specification, different thickness thrust washers must be installed on side gears.

17) On conventional type differentials, if disassembling differential case, drive straight pin from ring gear bolt side of differential case. Remove pinion shaft, side gears, pinion gears and thrust washers. See Fig. 1 or 2. On all drive axles, using press, press dust cover from companion flange and side gear shafts (if necessary).

#### Preliminary Reassembly & Adjustments

1) Using press, press NEW dust cover on companion flange and side gear shafts (if removed). On conventional type differentials,

install side gears, pinion gears, thrust washers and pinion shaft in differential case. Ensure hole in pinion shaft aligns with hole for straight pin in differential case.

2) Install side gear shaft in one side gear and recheck side gear backlash. Ensure side gear backlash is within specification. See AXLE ASSEMBLY SPECIFICATIONS table.

3) If side gear backlash is not within specification, install different thickness thrust washers on side gears and recheck side gear backlash. Thrust washer is available in thickness of .063" (1.60 mm), .067" (1.70 mm) and .071" (1.80 mm).

4) Once correct side gear backlash is obtained, install straight pin in differential case. Using hammer and punch, stake differential case at straight pin area.

5) On all drive axles, heat ring gear in boiling water. Remove ring gear from water and allow moisture to evaporate. Install ring gear on differential case with reference marks aligned. Temporarily install 2 ring gear bolts, opposite each other to ensure correct alignment of ring gear. Allow ring gear to cool.

**CAUTION:** Always install NEW ring gear bolts. DO NOT reuse old ring gear bolts. Ring gear bolts MUST NOT be tightened to specification until ring gear has cooled.

6) Once ring gear has cooled, install and tighten NEW ring gear bolts in a crisscross pattern to specification. See TORQUE SPECIFICATIONS. Using press, press NEW side bearings on differential case (if removed).

7) If bearing races were removed from differential carrier, install NEW adjusting washer in differential carrier. Ensure adjusting washer is same thickness as original adjusting washer removed. Adjusting washer is located between front bearing race and differential carrier. See Fig. 3.

8) Using press, press NEW bearing races in differential carrier. Press NEW front bearing on drive pinion (if removed). Install drive pinion in differential carrier. Install rear bearing, oil slinger (except turbo models with M/T) and companion flange on drive pinion. DO NOT install spacer, oil slinger (turbo models with M/T) and oil seal at this time.

9) Place differential carrier in press. Support rear side of drive pinion. Press rear bearing and companion flange on drive pinion. DO NOT press rear bearing too far onto drive pinion. Remove differential carrier from press.

10) Install drive pinion nut. Drive pinion nut will be tightened in small increments to obtain correct drive pinion rotating torque. Hold companion flange and slightly tighten drive pinion nut in small increments.

**CAUTION:** When tightening drive pinion nut, DO NOT overtighten nut, as spacer is not installed on drive pinion. Drive pinion nut must be tightened until correct drive pinion rotating torque is obtained.

11) Using INCH-lb. torque wrench installed on drive pinion nut, measure drive pinion rotating torque required to start rotation of drive pinion to determine drive pinion bearing preload for reassembly reference. Tighten drive pinion nut until correct drive pinion rotating torque is obtained. See AXLE ASSEMBLY SPECIFICATIONS table.

12) On turbo models with M/T, press NEW bearing outer race into each differential carrier retainer (if removed). Install adjusting washer on each differential carrier retainer. See Fig. 1. On all others, press adjusting washer and NEW bearing outer race into each differential carrier retainer (if removed). See Fig. 2.

13) On all models, install differential case with ring gear in differential carrier. DO NOT install "O" ring or oil seal in differential carrier retainer at this time. Install differential carrier retainers on differential carrier. Ensure differential carrier retainers are properly positioned. See Fig. 5.

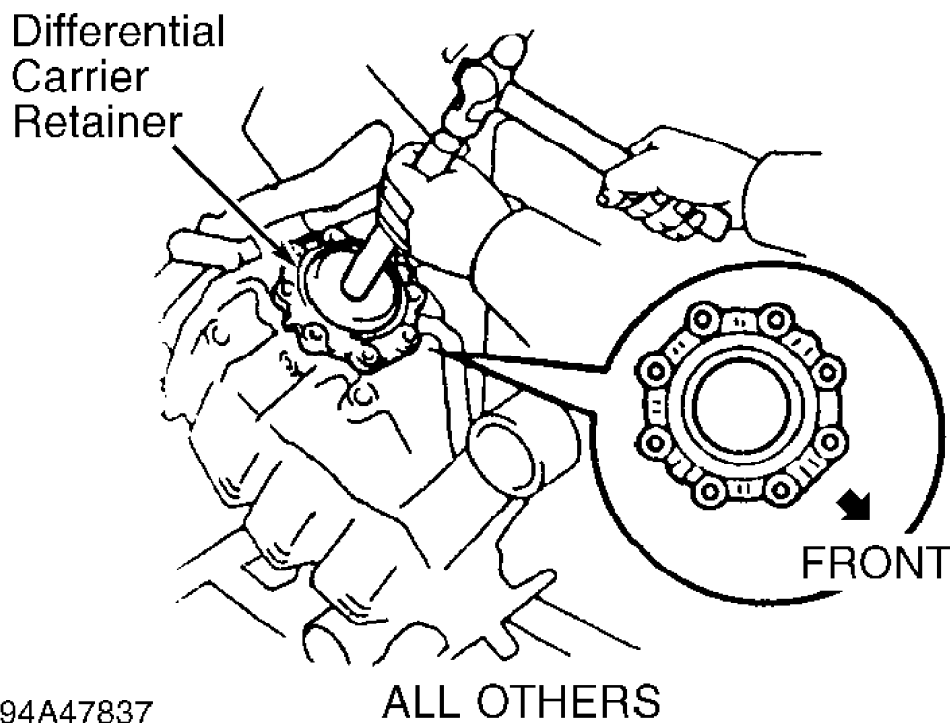
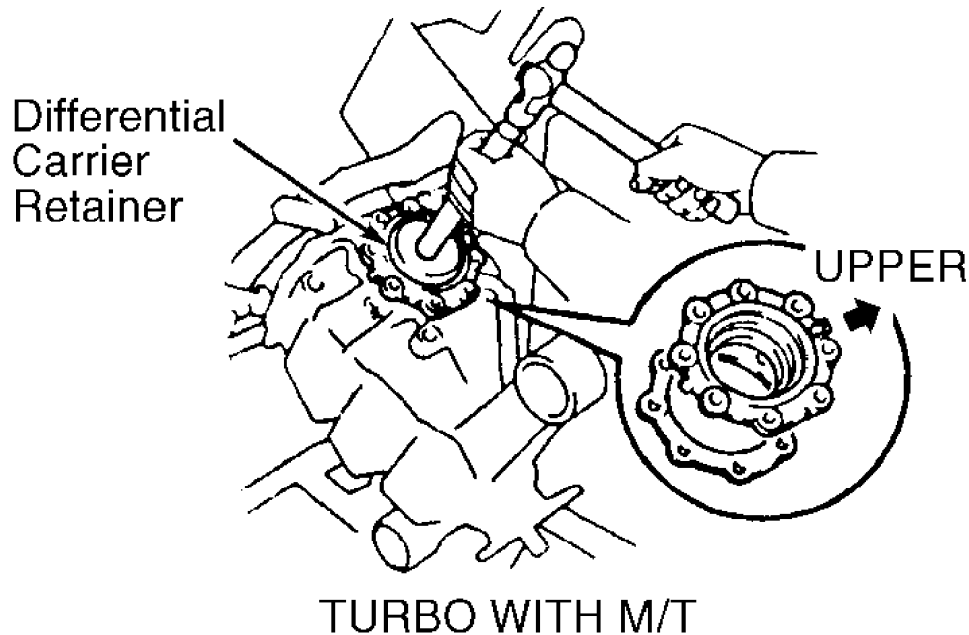

94A47837  
Fig. 5: Installing Differential Carrier Retainers  
Courtesy of Toyota Motor Sales, U.S.A., Inc.

14) Install and tighten differential carrier retainer bolts to specification. See TORQUE SPECIFICATIONS. Using dial indicator,

check ring gear backlash while rotating ring gear back and forth while holding drive pinion from rotating. See Fig. 4.

15) Check ring gear backlash at 3 different areas on ring gear and record ring gear backlash. Note if ring gear backlash is within specification. See AXLE ASSEMBLY SPECIFICATIONS table. Ring gear backlash should not vary more than .002" (.05 mm) between lowest reading and highest reading.

16) If ring gear backlash is not within specification, install different thickness adjusting washer on differential carrier retainer on ring gear side and recheck ring gear backlash. This is side opposite of ring gear teeth. Adjusting washers are available in various thickness.

17) Using INCH-lb. torque wrench installed on drive pinion nut, measure total assembled preload required to rotate drive pinion. This will determine preload for reassembly reference. Total assembled preload should be within specification. See AXLE ASSEMBLY SPECIFICATIONS table.

18) If total assembled preload is less than specified, install thicker adjusting washer on differential carrier retainer on teeth side of ring gear and recheck total assembled preload. If total assembled preload is greater than specified, install thinner adjusting washer on differential carrier retainer on teeth side of ring gear. Adjusting washers are available in various thickness.

NOTE: Changing thickness of adjusting washer .0008" (.02 mm) will change total assembled preload approximately .9 INCH lbs. (.1 N.m).

19) Check gear tooth contact pattern. See GEAR TOOTH CONTACT PATTERNS article in GENERAL INFORMATION. If gear tooth contact pattern is incorrect, install different thickness adjusting washer located in differential carrier, behind race for front bearing and recheck gear tooth contact pattern. Adjusting washers are available in various thickness.

20) Remove differential carrier retainers. Remove differential case with ring gear from differential carrier. Remove drive pinion from differential carrier.

#### Final Reassembly & Adjustments

1) Install NEW spacer on drive pinion. On turbo models with M/T, install oil slinger on drive pinion. On all models, install drive pinion in differential carrier. Install rear bearing and oil slinger (except turbo models with M/T) on drive pinion.

2) Apply grease to lip of NEW oil seal for drive pinion. Install oil seal in differential carrier until surface of oil seal is even with surface of differential carrier.

3) Place differential carrier in press. Support rear side of drive pinion. Press rear bearing and companion flange on drive pinion. DO NOT press rear bearing too far onto drive pinion. Remove differential carrier from press.

4) Coat threads on drive pinion and NEW drive pinion nut with gear oil. Install drive pinion nut. Drive pinion nut will be tightened in small increments to obtain correct drive pinion rotating torque. Hold companion flange and slightly tighten drive pinion nut.

CAUTION: When tightening drive pinion nut, DO NOT overtighten nut. Drive pinion nut must be tightened until correct drive pinion rotating torque is obtained.

5) Using INCH-lb. torque wrench installed on drive pinion nut, measure drive pinion rotating torque required to start rotation of drive pinion to determine drive pinion bearing preload. Tighten drive pinion nut until correct drive pinion rotating torque is

obtained. See AXLE ASSEMBLY SPECIFICATIONS table.

6) If drive pinion rotating torque exceeds specification, replace spacer and repeat procedure. If drive pinion rotating torque is less than specified, tighten drive pinion nut in small increments until correct rotating torque is obtained. DO NOT exceed MAXIMUM drive pinion nut torque. See TORQUE SPECIFICATIONS. If maximum torque is exceeded, replace spacer and repeat procedure. DO NOT back off drive pinion nut.

7) Once correct drive pinion rotating torque is obtained, stake drive pinion nut against drive pinion. Install differential case with ring gear in differential carrier.

8) Coat NEW "O" ring with gear oil and install on differential carrier retainers. Using press, press NEW oil seal into differential carrier retainers. Coat lip of oil seal with grease.

9) Install differential carrier retainers on differential carrier. Ensure differential carrier retainers are properly positioned. See Fig. 5. Install and tighten differential carrier retainer bolts to specification. See TORQUE SPECIFICATIONS.

10) Install NEW snap ring on end of side gear shafts. Coat snap rings with grease. Using hammer and brass drift, install side gear shafts. Ensure side gear shafts cannot be pulled from differential assembly.

11) To ensure proper installation of side gear shaft installation distance between side gear shafts. See Fig. 6. Side gear shaft installation distance should be within specification. See AXLE ASSEMBLY SPECIFICATIONS table.

12) Recheck ring gear backlash, total assembled preload and gear tooth contact pattern. Apply sealant on differential carrier cover and install. Install and tighten bolts to specification. See TORQUE SPECIFICATIONS. Install and tighten breather plug on differential carrier cover to specification.

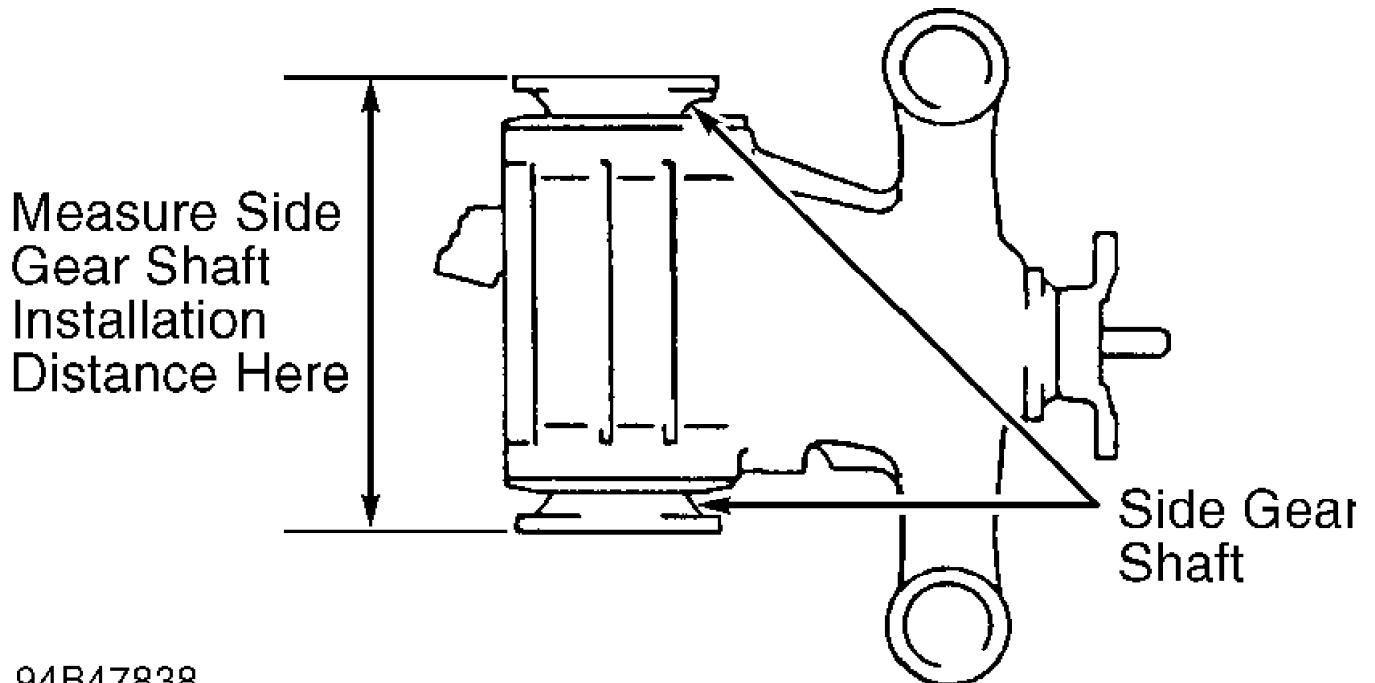

94B47838

Fig. 6: Measuring Side Gear Shaft Installation Distance  
Courtesy of Toyota Motor Sales, U.S.A., Inc.

AXLE ASSEMBLY SPECIFICATIONS TABLE

Application	Specification
Drive Pinion Rotating Torque	
Turbo M/T	
New Bearings .....	17.3-21.7 INCH Lbs. (2.0-2.5 N.m)
Used Bearings .....	8.7-10.4 INCH Lbs. (1.0-1.2 N.m)
All Others	
New Bearings .....	10.4-16.0 INCH Lbs. (1.2-1.8 N.m)
Used Bearings .....	4.3-6.9 INCH Lbs. (.5-.8 N.m)
Drive Pinion Shaft Runout .....	.0031" (.080 mm)
Ring Gear Backlash .....	.0031-.0051" (.080-.130 mm)
Ring Gear Runout	
Turbo M/T .....	.0031" (.080 mm)
All Others .....	.0020" (.050 mm)
Side Gear Backlash .....	.0020-.0079" (.050-.200 mm)
Side Gear Shaft Installation Distance	
Turbo M/T .....	11.525-11.577" (292.75-294.05 mm)
All Others .....	11.057-11.131" (280.85-282.75 mm)
Total Assembled Preload (1)	
Turbo M/T .....	3.5-5.2 INCH lbs. (.4-.6 N.m)
All Others .....	4.3-6.9 INCH lbs. (.5-.8 N.m)

(1) - Add this amount to drive pinion rotating torque to obtain total preload.

**TORQUE SPECIFICATIONS**

TORQUE SPECIFICATIONS TABLE

Application	Ft. Lbs. (N.m)
Axle Shaft Flange-To-Side Gear Shaft Bolt .....	61 (83)
Breather Plug .....	15 (20)
Crossmember Brace Bolt .....	(1)
Differential Assembly Mounting Bolt	
Bolt At Front Of Differential Assembly .....	90 (122)
Bolt At Rear Of Differential Assembly .....	105 (142)
Differential Carrier Cover Bolt	
Turbo M/T .....	58 (79)
All Others .....	34 (46)
Differential Carrier Retainer Bolt	
Turbo M/T .....	35 (47)
All Others .....	16 (22)
Drive Pinion Nut Maximum Torque	
Turbo M/T .....	376 (510)
All Others .....	362 (490)
Drive Shaft Center Bearing Bolt .....	36 (49)
Drive Shaft Companion Flange Bolt .....	58 (79)
Drive Shaft-To-Transmission Companion	
Flange Nut (Turbo Models) .....	41 (56)
Ring Gear Bolt (2)	
Step 1 .....	47 (64)
Step 2 .....	Additional 60-90 Degrees
Stabilizer Bar Link-To-Lower	
Suspension Arm Nut .....	54 (73)
Stabilizer Bar Mounting Bracket Bolt .....	23 (31)
Wheel Lug Nut .....	76 (103)

(1) - Tighten bolt to 115 INCH lbs. (13.0 N.m).

(2) - Always use NEW bolts. DO NOT reuse old bolts.

---