

## REAR BRAKE (2JZ—GTE) COMPONENTS

BR0AX-06

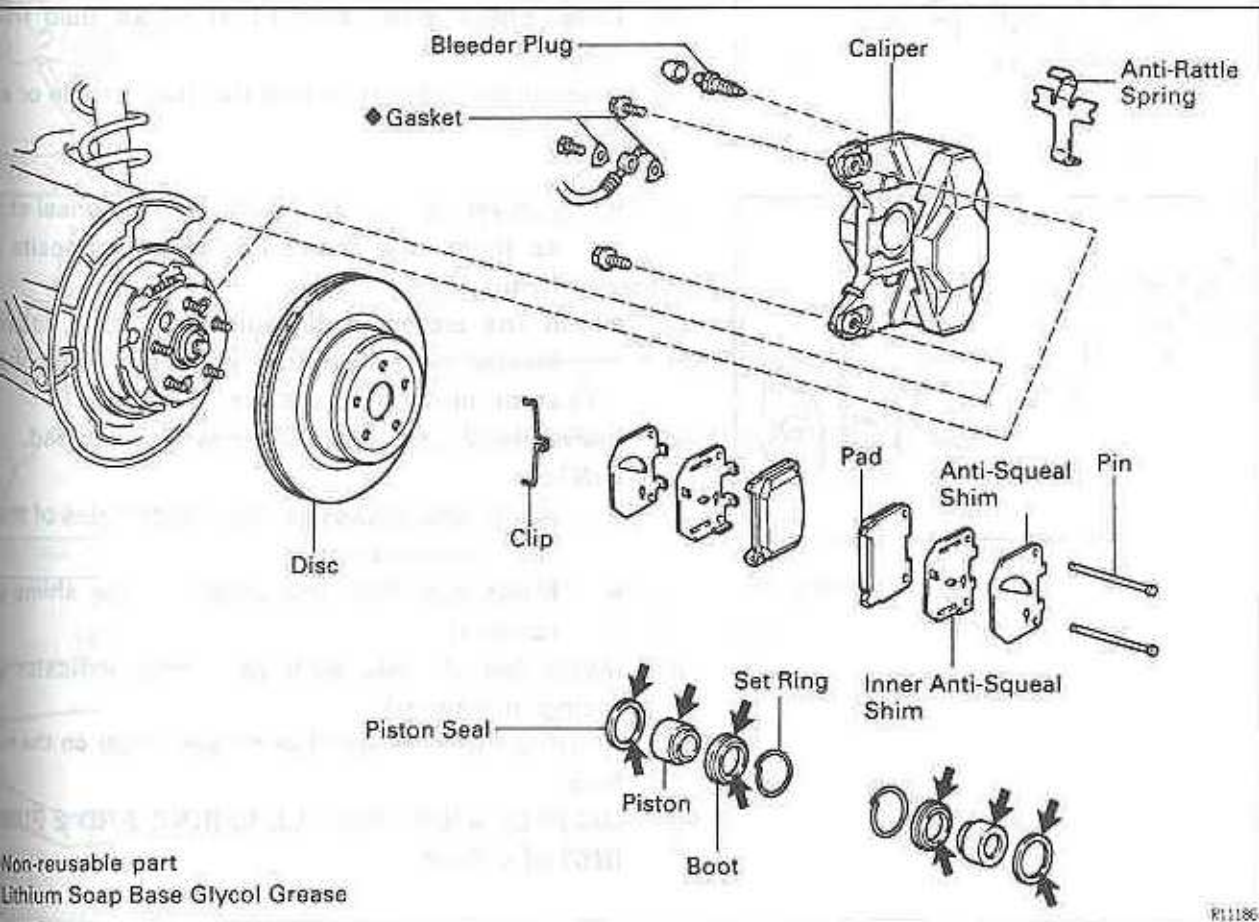

Non-reusable part  
Lithium Soap Base Glycol Grease

BR

R11186

BR0UG-02

## BRAKE PADS REPLACEMENT

### 1. REMOVE REAR WHEEL

Remove the wheel and temporarily fasten the disc with the hub nuts.

### 2. INSPECT PAD LINING THICKNESS

Check the pad thickness and replace pads if not within specification.

**Minimum thickness: 1.0 mm (0.039 in.)**

### 3. REMOVE THESE PARTS:

- Clip and 2 pins
- Anti-rattle spring
- 2 pads
- 4 anti-squeal shims

**NOTICE:** The anti-rattle springs and clip can be used again provided that they have sufficient rebound, no deformation, cracks or wear, and have had all rust, dirt and foreign particles cleaned off.

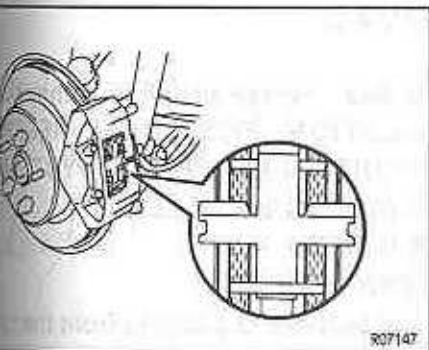

R07147

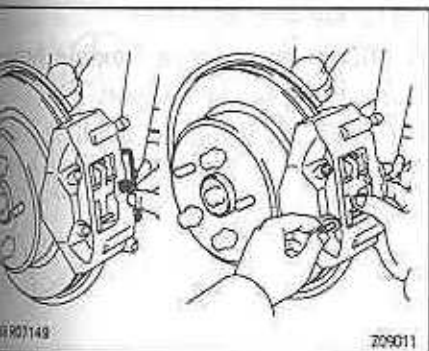

R07148

Z09011

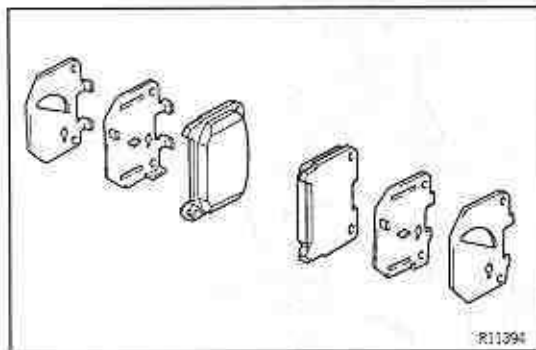
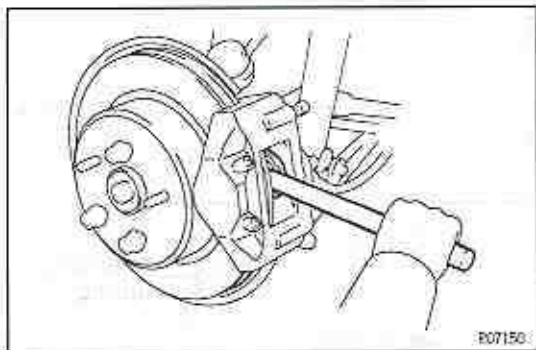

#### 4. CHECK DISC THICKNESS AND RUNOUT

(See page BR—34)

#### 5. INSTALL NEW PADS

**NOTICE:** When replacing worn pads, the anti-squeal shims must be replaced together with the pads.

- (a) Draw out a small amount of brake fluid from the reservoir.
- (b) Press in the pistons with a hammer handle or equivalent.

**HINT:**

- Always change the pads on one wheel at a time as there is a possibility of the opposite piston flying out.
- If the piston is difficult to push in, loosen the bleeder plug and push in the piston while letting some brake fluid escape.

- (c) Install the 2 anti-squeal shims on each pad.

**HINT:**

- Apply disc brake grease to both sides of the anti-squeal shim.
- Make sure that the arrow on the shims points upward.

- (d) Install the 2 pads with pad wear indicator pins facing downward.

**NOTICE:** Do not allow oil or grease to get on the rubber face.

#### 6. INSTALL ANTI-RATTLE SPRING AND 2 PINS

#### 7. INSTALL CLIP

### CALIPER REMOVAL

Installation is in the reverse order of removal. **AFTER INSTALLATION, FILL BRAKE RESERVOIR WITH BRAKE FLUID, BLEED BRAKE SYSTEM (See page BR—7) AND CHECK FOR LEAKS**

1. REMOVE REAR WHEEL
2. DISCONNECT BRAKE HOSE

- (a) Remove the union bolt and 2 gaskets from the caliper, then disconnect the brake hose from the caliper.

**Torque: 30 N·m (310 kgf·cm, 22 ft·lbf)**

**INSTALLATION HINT:** Install the flexible hose securely in the lock hole in the caliper.

- (b) Use a container to catch the brake fluid.

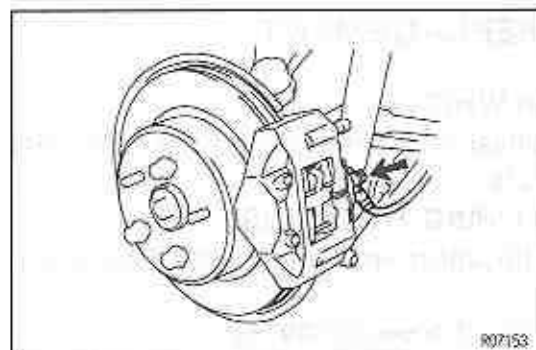

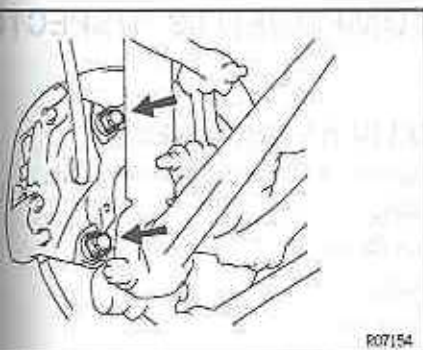

**3. REMOVE CALIPER**

Remove the 2 mounting bolts and caliper.  
Torque: 104 N·m (1,065 kgf·cm, 77 ft·lbf)

**4. REMOVE THESE PARTS:**

- (a) Clip
- (b) 2 pins
- (c) Anti-rattle spring
- (d) 2 pads
- (e) 4 anti-squeal shims

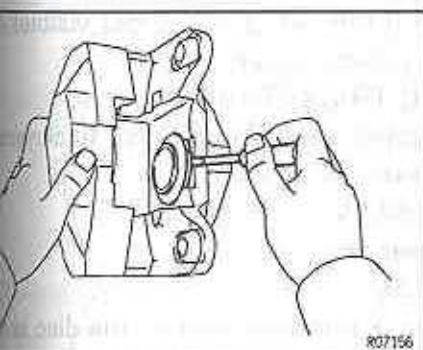

**CALIPER DISASSEMBLY**

Assembly is in the reverse order of disassembly.  
**ASSEMBLY NOTICE:** Apply lithium soap base glycol grease to the parts indicated by the arrows (See page BR-31).

**1. REMOVE CYLINDER BOOT SET RINGS AND BOOTS**

Using a screwdriver, remove the 2 cylinder boot set rings and 2 boots.

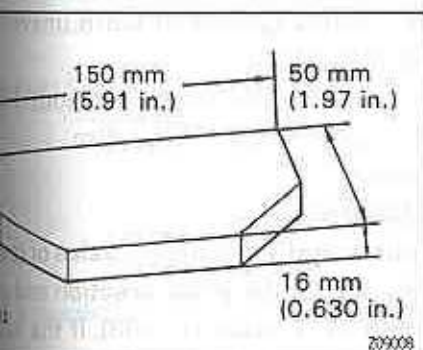

**2. REMOVE PISTONS FROM CYLINDER**

- (a) Prepare a wooden plate to hold the pistons.

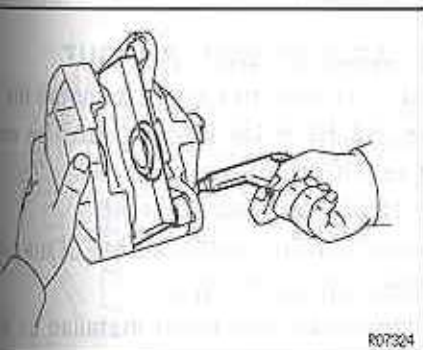

- (b) Place the plate between the pistons and insert a pad on one side.

- (c) Use compressed air to remove the pistons alternately from the caliper.

**DISASSEMBLY CAUTION:** Do not place your fingers in front of the pistons when using compressed air.

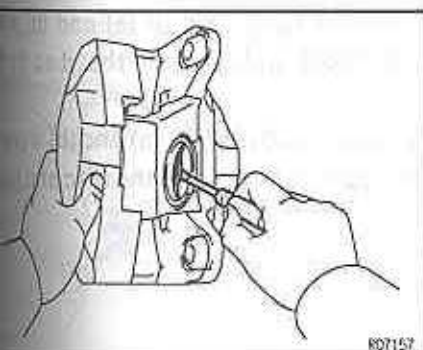

**3. REMOVE PISTON SEALS**

Using a screwdriver, remove the 2 seals from the cylinder.

BR

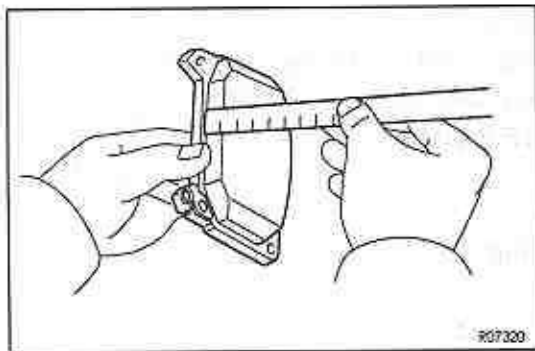

R07320

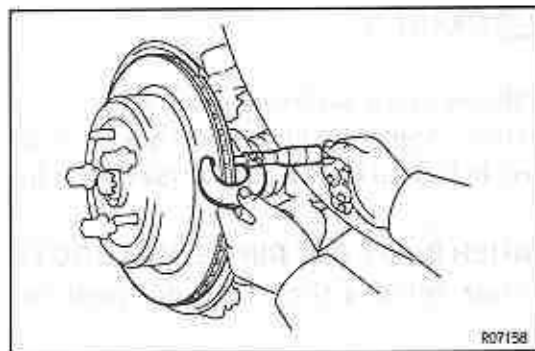

R07158

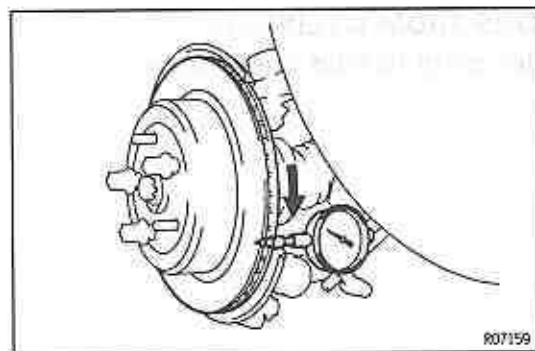

R07159

## REAR BRAKE COMPONENTS INSPECTION AND REPAIR

### 1. MEASURE PAD LINING THICKNESS

Using a ruler, measure the lining thickness.

**Standard thickness:**

11.0 mm (0.433 in.)

**Minimum thickness:**

1.0 mm (0.039 in.)

Replace the pads if the thickness is less than minimum (the 1.0 mm slit is no longer visible) or shows signs of uneven wear.

### 2. MEASURE DISC THICKNESS

Using a micrometer, measure the disc thickness.

**Standard thickness:**

16.0 mm (0.630 in.)

**Minimum thickness:**

15.0 mm (0.591 in.)

Replace the disc if the thickness of the disc is at minimum thickness or less. Replace the disc or it on a lathe if it is badly scored or worn unevenly.

### 3. MEASURE DISC RUNOUT

Using a dial indicator, measure disc runout (0.39 in.) from the outer edge of the disc.

**Maximum disc runout:**

0.05 mm (0.0020 in.)

If the disc's runout is at the maximum value or greater, check the bearing play in the axial direction and the axle hub runout (See page SA-38). If the bearing play and axle hub runout are not abnormal, adjust the disc runout.

### 4. IF NECESSARY, ADJUST DISC RUNOUT

- (a) Remove the hub nuts and the disc. Reinstall the disc 1/5 of a turn round from its original position on the hub. Install and torque the hub nuts.

**Torque: 103 N·m (1,050 kgf·cm, 76 ft·lbf)**

Remeasure the disc runout. Make a note of the runout and the disc's position on the hub.

- (b) Repeat (a) until the disc has been installed on all remaining hub positions.
- (c) If the minimum runout recorded in (a) and (b) is less than 0.05 mm (0.0020 in.), install the disc in the minimum runout position.
- (d) If the minimum runout recorded in (a) and (b) is greater than 0.05 mm (0.0020 in.), replace the disc and repeat step 3.