

F - BASIC TESTING - TURBO

1996 Toyota Supra

1996 ENGINE PERFORMANCE
Toyota Basic Diagnostic Procedures

Supra - Turbo

INTRODUCTION

The following diagnostic steps will help prevent overlooking a simple problem. This is also where to begin diagnosis for a no-start condition.

The first step in diagnosing any driveability problem is verifying the customer's complaint with a test drive under the conditions problem reportedly occurred.

Before entering self-diagnostics, perform a careful and complete visual inspection. Most engine control problems result from mechanical breakdowns, poor electrical connections or damaged/misrouted vacuum hoses. Before condemning the computerized system, perform each test listed in this article.

NOTE: Perform all voltage tests with a Digital Volt-Ohmmeter (DVOM) with a minimum 10-megohm input impedance, unless stated otherwise in test procedure.

PRELIMINARY INSPECTION & ADJUSTMENTS

VISUAL INSPECTION

Visually inspect all electrical wiring, looking for chafed, stretched, cut or pinched wiring. Ensure electrical connectors fit tightly and are not corroded. Ensure vacuum hoses are properly routed and are not pinched or cut. See M - VACUUM DIAGRAMS article to verify routing and connections (if necessary). Inspect air induction system for possible vacuum leaks.

MECHANICAL INSPECTION

Compression

Check engine mechanical condition with a compression gauge, vacuum gauge, or engine analyzer. See engine analyzer manual for specific instructions. See COMPRESSION SPECIFICATIONS table.

WARNING: DO NOT use ignition switch during compression tests. Use a remote starter to crank engine. Fuel injectors on many models are triggered by ignition switch during cranking mode, which can create a fire hazard or contaminate the engine's oiling system.

COMPRESSION SPECIFICATIONS TABLE

Application	Specification
Normal Compression Pressure	156 psi (10.9 kg/cm ²)
Minimum Compression Pressure	128 psi (9.0 kg/cm ²)
Maximum Variation Between Cylinders	14 psi (1.0 kg/cm ²)

FUEL SYSTEM

Basic diagnosis of fuel system should begin by checking fuel pump operation and fuel pressure.

WARNING: ALWAYS release fuel pressure before disconnecting any fuel injection-related component. DO NOT allow fuel to contact engine or electrical components.

FUEL PUMP OPERATION

NOTE: Electric fuel pump operation is checked by using data link connector No. 1.

Checking Fuel Pump Operation Using Data Link Connector No. 1

1) Install Jumper Wire (SST 09843-18020) between +B and FP terminals of data link connector No. 1. See Fig. 1. Data link connector No. 1 is located at passenger's side rear corner of firewall in the engine compartment.

2) Turn ignition on. Listen for fuel pump operating sound and feel for pressure in fuel line near fuel filter. Turn ignition off. Remove jumper wire. If fuel pump operates, check fuel pressure. See FUEL PRESSURE.

3) If fuel pump does not operate, connect a jumper wire from positive battery terminal to FP terminal of data link connector No. 1. If fuel pump operates, EFI main relay, EFI No. 2 relay or fuel pump Electronic Control Unit (ECU) may be defective. For relay application and explanation of relay operation, see FUEL PUMP CONTROL CIRCUIT. If relays are okay, check wiring circuit and fuses.

4) If fuel pump does not operate, check for defective fuel pump, open circuit between data link connector No. 1 and fuel pump or defective fuel pump ground. See appropriate wiring diagram in L - WIRING DIAGRAMS article.

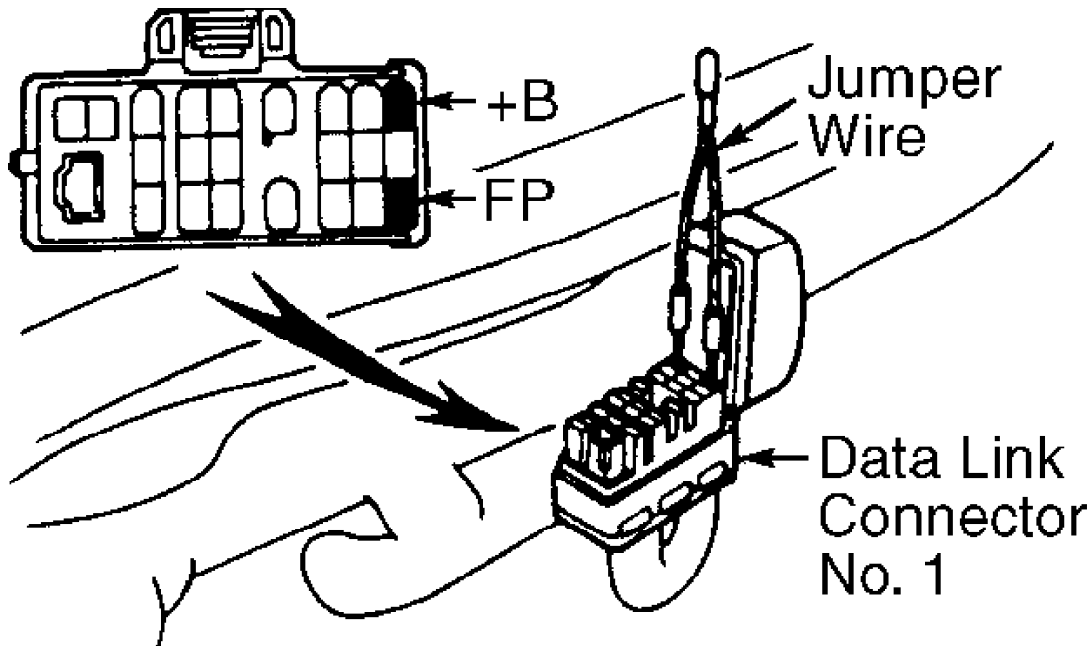

95G31332

Fig. 1: Installing Jumper Wire In Data Link Connector No. 1
Courtesy of Toyota Motor Sales, U.S.A., Inc.

FUEL PRESSURE

NOTE: All models use in-tank fuel pump.

1) Ensure battery is fully charged and ignition is off. Disconnect negative battery cable.

2) Note location for fuel pressure gauge installation. See Fig. 2. Place container under fuel filter. Cover union bolt with shop towel. Slowly loosen union bolt to release fuel pressure.

3) Remove union bolt and gaskets. Install Fuel Pressure Gauge (SST 09268-45012) using NEW gaskets. See Fig. 2. Tighten union bolt. Reconnect negative battery cable.

4) Install Jumper Wire (SST 09843-18020) between +B and FP terminals of data link connector No. 1. See Fig. 1.

5) Turn ignition on and note fuel pressure. Fuel pressure should be within specification. See FUEL PUMP PERFORMANCE table. If fuel pressure exceeds specification, replace fuel pressure regulator, located on the delivery pipe. If fuel pressure is less than specified, check for defective fuel lines, connections, fuel pump, fuel filter or fuel pressure regulator.

6) Remove jumper wire from data link connector No. 1. Start engine and allow engine to idle. Disconnect and plug vacuum line at fuel pressure regulator. Note fuel pressure. Fuel pressure should be within specification. See REGULATED FUEL PRESSURE table.

7) Reconnect vacuum hose on fuel pressure regulator and note fuel pressure. Fuel pressure should be within specification. See REGULATED FUEL PRESSURE table.

8) If fuel pressure is not within specification, check for defective vacuum hose or fuel pressure regulator. Shut engine off and note fuel pressure.

9) Fuel pressure should hold at least 21 psi (1.5 kg/cm²) for a minimum of 5 minutes. If fuel pressure does not hold as specified, check for defective fuel pump, fuel injector or fuel pressure regulator.

10) Disconnect negative battery cable. Remove fuel pressure gauge. Reinstall union bolt using NEW gaskets. Tighten union bolt. Install negative battery cable.

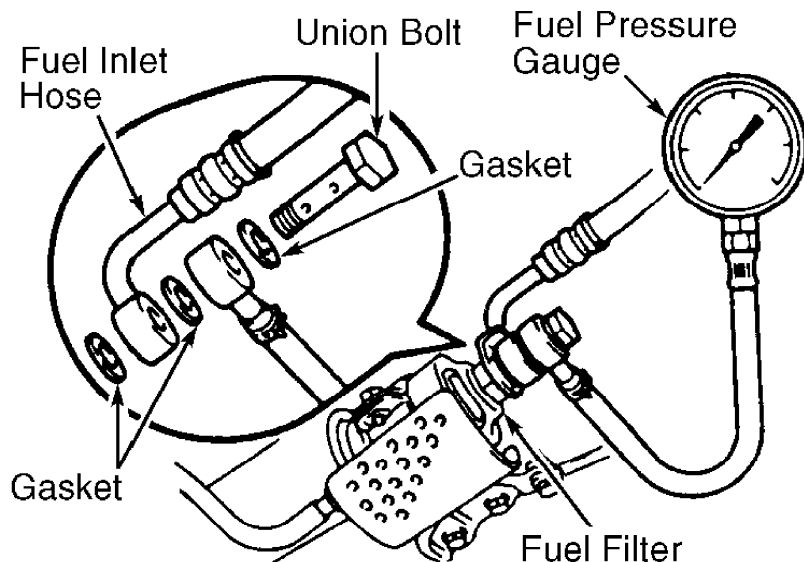

95C31619

Fig. 2: Installing Fuel Pressure Gauge
Courtesy of Toyota Motor Sales, U.S.A., Inc.

NOTE: For more information on checking fuel injectors and other fuel sub-systems, see I - SYSTEM/COMPONENT TESTS article.

FUEL PUMP PERFORMANCE TABLE

Application	Pressure psi (kg/cm ²)
Turbo	(1) 33-40 (2.3-2.8)

(1) - Check fuel pressure with Jumper Wire (SST 09843-18020) installed between terminals +B and FP on data link connector No. 1, ignition on and engine off.

REGULATED FUEL PRESSURE TABLE

Application	At Idle W/Vacuum psi (kg/cm ²)	At Idle W/O Vacuum psi (kg/cm ²)
Turbo	24-31 (1.7-2.2) 33-40 (2.3-2.8)

FUEL PUMP CONTROL CIRCUIT

NOTE: For information on testing relays and fuel system components, see I - SYSTEM/COMPONENT TESTS article. Relays may be identified by appropriate illustration in E - THEORY/OPERATION article. Vehicles are equipped with different combinations of fuel system electrical components. For complete wiring circuit of electrical components on a specific model, see appropriate wiring diagram in L - WIRING DIAGRAMS article.

EFI Main Relay & No. 2 EFI Relay

The No. 1 EFI fuse supplies constant battery voltage to EFI main relay. The EFI main relay is turned on by M-REL terminal of Engine Control Module (ECM). When EFI main relay is turned on, voltage is supplied to No. 2 EFI relay, +B terminal of ECM, data link connector No. 1 and various other electrical components. The EFI main relay and No. 2 EFI relay are located in engine compartment relay box at driver's side front strut tower.

NOTE: No. 2 EFI relay may also be referred to as EFI No. 2 relay.

The No. 2 EFI fuse supplies constant battery voltage to No. 2 EFI relay. When No. 2 EFI relay is energized by voltage supplied from EFI main relay, relay closes and voltage is provided to +B terminal on fuel pump Electronic Control Unit (ECU). Fuel pump ECU is located in driver's side rear corner of the trunk. The ECM provides signals to fuel pump ECU for controlling fuel pump operation. Fuel pump ECU then provides voltage to the fuel pump.

NOTE: EFI main relay may also be referred to as EFI relay.

IGNITION CHECKS (DISTRIBUTORLESS IGNITION SYSTEM)

SPARK TEST

1) Disconnect negative battery cable. Remove oil filler cap. Remove timing belt cover and gasket, located above ignition coils on top of cylinder head. Remove PCV hoses. Disconnect engine wiring clamps on ignition coils.

2) Disconnect electrical connectors from ignition coils. Remove bolts and ignition coils. Reconnect negative battery cable and electrical connectors on ignition coils.

3) Remove spark plugs. Install spark plug on each ignition coil. Ground spark plug against cylinder block.

CAUTION: To prevent gasoline from being injected, DO NOT crank engine for longer than 5 seconds.

4) Crank engine and check for spark. If spark does not exist, check ignition coil and igniter electrical connections. If electrical connections are okay, go to next step. If electrical connections are defective, repair as necessary and recheck for spark.

5) Turn ignition on. Check for battery voltage at igniter and ignition coil positive terminal. If battery voltage exists, go to next step. If battery voltage does not exist, check wiring between ignition switch, ignition coil and igniter. See appropriate wiring diagram in L - WIRING DIAGRAMS article.

6) Check ignition coil resistance. See IGNITION COIL RESISTANCE under IGNITION CHECKS (DISTRIBUTORLESS IGNITION SYSTEM). Replace ignition coil if resistance is not within specification. If ignition coil resistance is within specification, go to next step.

7) Check resistance of camshaft position sensors and crankshaft position sensor. See CAMSHAFT POSITION SENSOR and CRANKSHAFT POSITION SENSOR under IGNITION CHECKS (DISTRIBUTORLESS IGNITION SYSTEM).

8) Replace camshaft position sensor or crankshaft position sensor if resistance is not within specification. If camshaft position sensor and crankshaft position sensor resistances are within specification, go to next step.

9) Check ignition IGT signal from Engine Control Module (ECM). If ignition IGT signal from ECM is defective, a diagnostic trouble Code No. 14 will be set in the ECM memory to indicate a igniter circuit malfunction. See G - TESTS W/CODES article for diagnostic trouble code.

10) If IGT signal is okay, substitute another igniter and recheck system operation. If IGT signal is defective, check wiring between Engine Control Module (ECM), distributor and igniter. If wiring is defective, repair wiring as necessary and recheck system operation. If wiring is okay, substitute another ECM and recheck system operation. Reinstall components.

IGNITION COIL RESISTANCE

1) Disconnect negative battery cable. Remove oil filler cap. Remove timing belt cover and gasket, located above ignition coils on top of cylinder head.

2) Remove PCV hoses. Disconnect engine wiring clamps on ignition coils. Disconnect electrical connectors from ignition coils.

3) Using ohmmeter, check ignition coil primary resistance between positive (+) and negative (-) terminals of each ignition coil. These are the terminals that electrical connector was installed on.

4) Replace ignition coil if primary resistance is not within specification. See IGNITION COIL RESISTANCE table.

5) Ignition coil secondary resistance cannot be checked. Reinstall electrical connectors on ignition coils, timing belt cover, gasket and negative battery cable.

IGNITION COIL RESISTANCE TABLE

Application	Primary	Secondary
Cold (1)	.54-.84	(3)

Hot (2)68-.98 (3)

- (1) - Cold is with temperature of 14-122°F (-10-50°C).
- (2) - Hot is with temperature of 122-212°F (50-100°C).
- (3) - Secondary ignition coil resistance cannot be checked.

CAMSHAFT POSITION SENSOR

1) Disconnect electrical connector from camshaft position sensors, located on side of cylinder head, near intake manifold. See Fig. 3. Using ohmmeter, check resistance between electrical terminals on each camshaft position sensor.

2) Replace camshaft position sensor if resistance is not within specification. See CAMSHAFT POSITION SENSOR RESISTANCE table. Reinstall electrical connectors on camshaft position sensors.

CAMSHAFT POSITION SENSOR RESISTANCE TABLE

Application	Ohms
Aisan Sensor	
Cold (1)	985-1600
Hot (2)	1265-1890
Nippondenso Sensor	
Cold (1)	835-1400
Hot (2)	1060-1645

- (1) - Cold is with temperature of 14-122°F (-10-50°C).
- (2) - Hot is with temperature of 122-212°F (50-100°C).

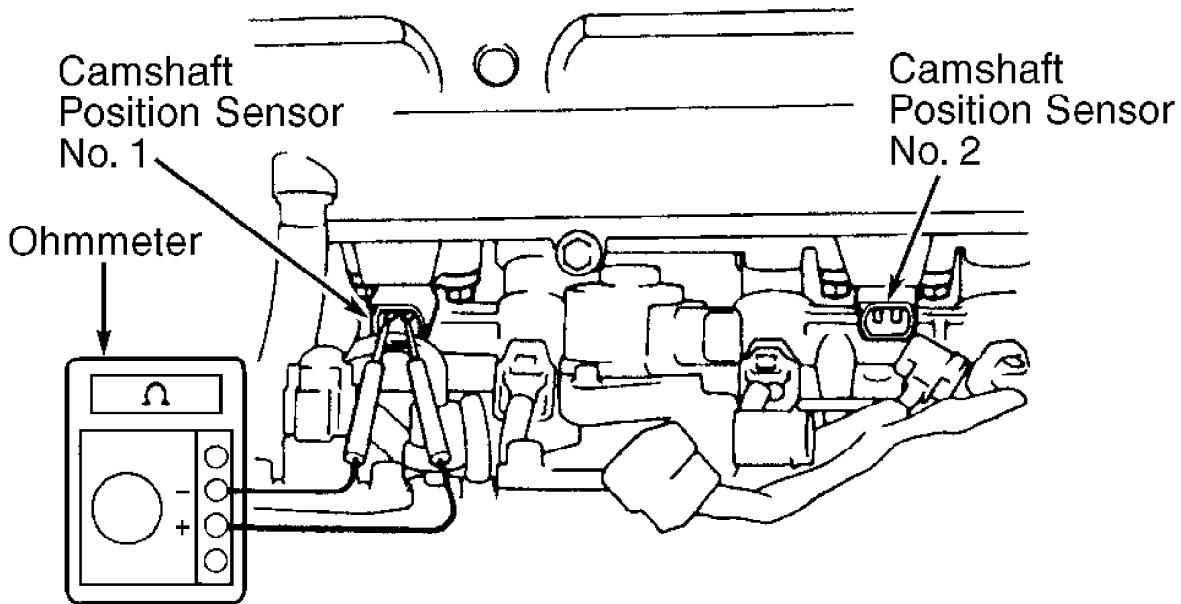

95G31365

Fig. 3: Identifying & Checking Camshaft Position Sensor
 Courtesy of Toyota Motor Sales, U.S.A., Inc.

CRANKSHAFT POSITION SENSOR

1) Remove air tube for charge air cooler, located near front of crankshaft, to access electrical connector for crankshaft position sensor. Disconnect electrical connector for crankshaft position sensor. See Fig. 4. Electrical connector is located on passenger's side front corner of engine.

2) Crankshaft position sensor is located near crankshaft pulley, just above oil pan on passenger's side. Using ohmmeter, check resistance between terminals on electrical connector for crankshaft position sensor.

3) Replace crankshaft position sensor if resistance is not within specification. See CRANKSHAFT POSITION SENSOR RESISTANCE table. Reinstall electrical connector and air tube.

CRANKSHAFT POSITION SENSOR RESISTANCE TABLE

Application	Ohms
Cold (1)	835-1400
Hot (2)	1060-1645

(1) - Cold is with temperature of 14-122°F (-10-50°C).

(2) - Hot is with temperature of 122-212°F (50-100°C).

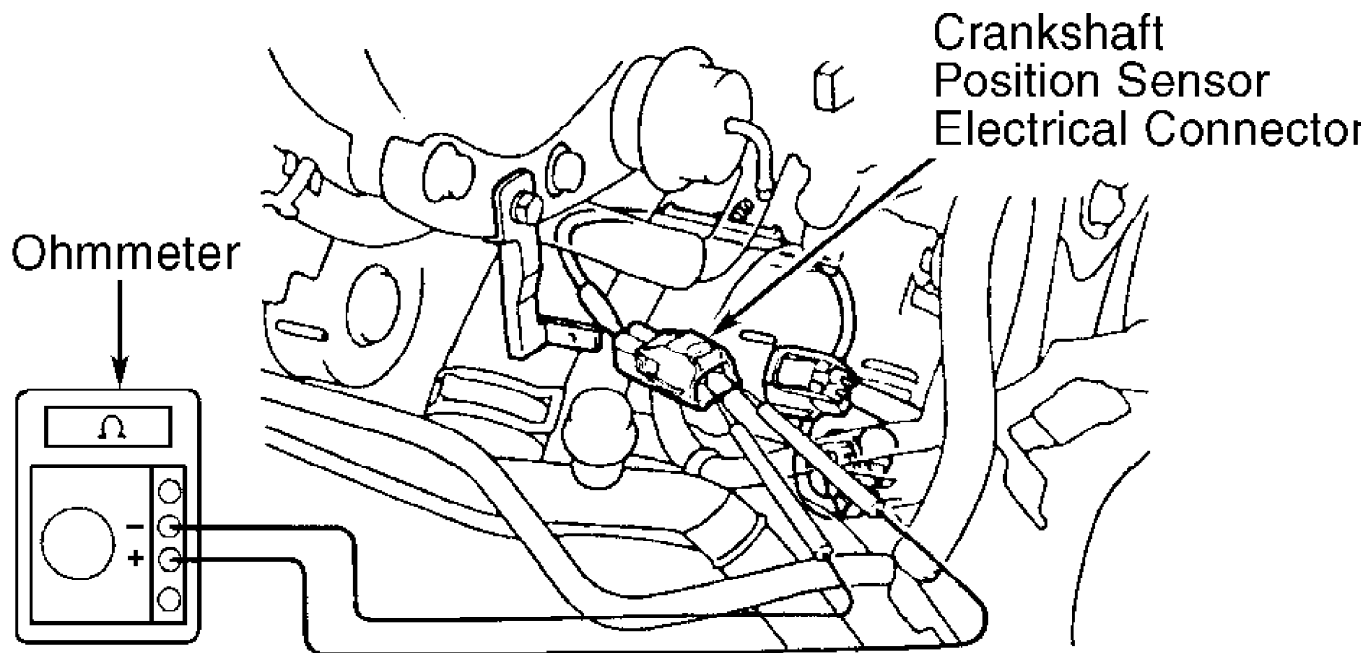

Fig. 4: Identifying & Checking Crankshaft Position Sensor
 Courtesy of Toyota Motor Sales, U.S.A., Inc.

IDLE SPEED & IGNITION TIMING

Ensure idle speed and ignition timing are set to specification. For adjustment procedures, see D - ADJUSTMENTS article.

SUMMARY

If no faults were found while performing F - BASIC TESTING,

proceed to appropriate G - TESTS W/ CODES article. If no hard diagnostic trouble codes are found in self-diagnostics, proceed to H - TESTS W/O CODES article for diagnosis by symptom (i.e., ROUGH IDLE, NO START, etc.) or intermittent diagnostic procedures.