

## D - ADJUSTMENTS

### 1996 Toyota Supra

1996 ENGINE PERFORMANCE  
Toyota On-Vehicle Adjustments

Supra

#### ENGINE MECHANICAL

Before performing any on-vehicle adjustments to fuel or ignition systems, ensure engine mechanical condition is okay.

#### VALVE CLEARANCE

1) Check valve clearance with engine cold. Remove necessary components to access valve covers. Remove upper timing belt cover, valve covers and gaskets.

CAUTION: Ensure crankshaft is always rotated clockwise.

2) Rotate crankshaft pulley clockwise so crankshaft pulley groove aligns with "0" mark on timing belt cover and cylinder No. 1 (front cylinder) is at TDC on compression stroke. Ensure timing marks on camshaft sprockets are aligned with timing marks on timing belt cover. See Fig. 1. If timing marks are not aligned, rotate crankshaft pulley clockwise one full revolution (360 degrees).

3) Using feeler gauge, measure and record valve clearance of intake valves on cylinders No. 1, 2 and 4, and exhaust valves on cylinders No. 1, 3 and 5. See Fig. 5.

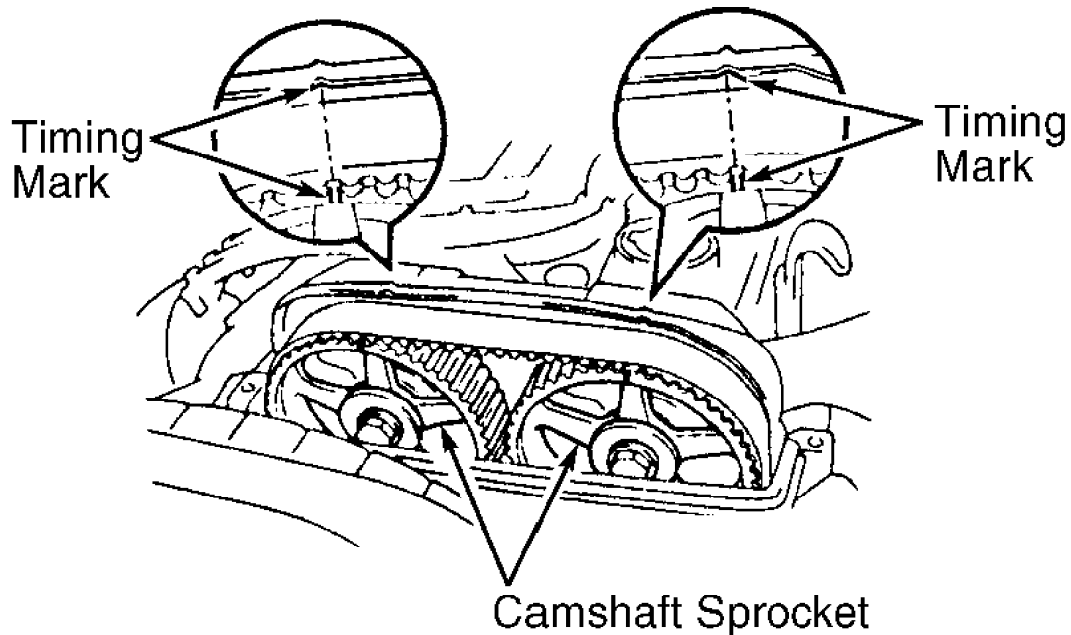

93G78242

Fig. 1: Aligning Camshaft Sprocket Timing Marks  
Courtesy of Toyota Motor Sales, U.S.A., Inc.

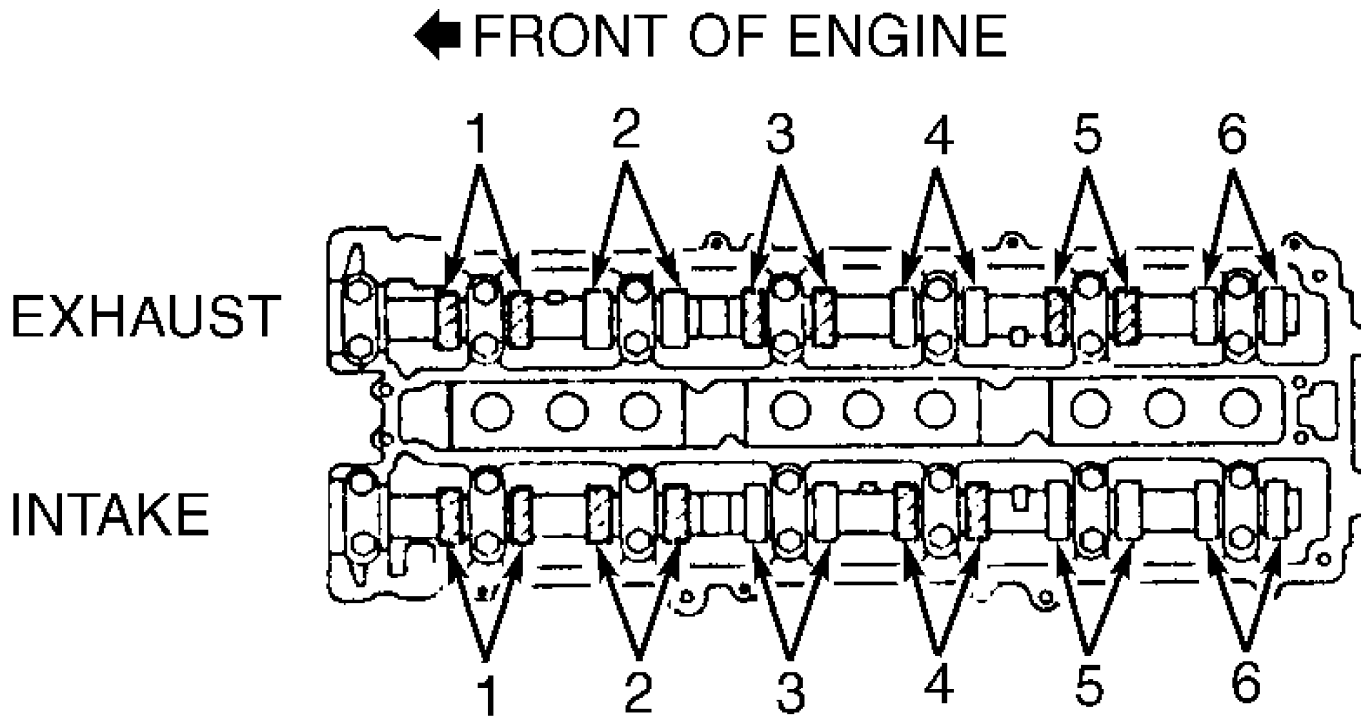

**93H78243**

Fig. 2: Identifying Cylinder Numbers & Valve Arrangement  
 Courtesy of Toyota Motor Sales, U.S.A., Inc.

4) Rotate crankshaft pulley clockwise one full revolution (360 degrees) and realign crankshaft pulley groove with "0" mark on timing belt cover. Using feeler gauge, measure and record valve clearance of intake valves on cylinders No. 3, 5 and 6, and exhaust valves on cylinders No. 2, 4 and 6. See Fig. 5.

5) Ensure valve clearance is within specification. See VALVE CLEARANCE SPECIFICATIONS table.

VALVE CLEARANCE SPECIFICATIONS TABLE

Application	(1) In. (mm)
Intake .....	.006-.010 (.15-.25)
Exhaust .....	.010-.014 (.25-.35)

(1) - Adjust valve clearance with engine cold.

6) If valve clearance adjustment is required, rotate crankshaft pulley so camshaft lobe is facing upward on valve to be adjusted. Rotate valve lifter so notch area on valve lifter is at 90-degree angle to camshaft. This will place notch area perpendicular to camshaft.

7) Valve Clearance Adjuster (SST 09248-55040) is used for adjusting valve clearance. Press valve lifter downward using SST "A" of valve clearance adjuster. See Fig. 3. Install SST "B" between camshaft and valve lifter. Remove SST "A".

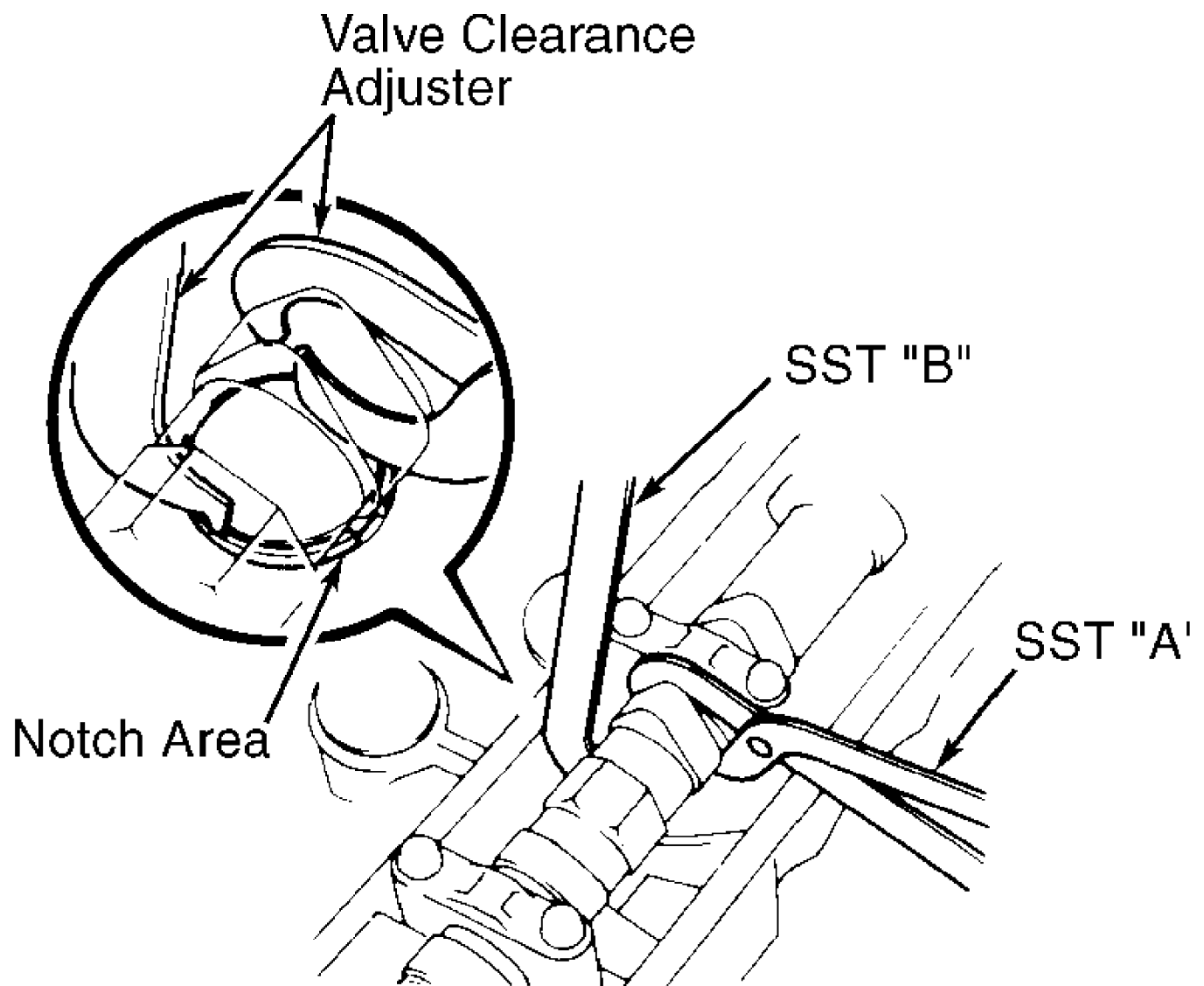

### 94G44236

Fig. 3: Removing & Installing Typical Valve Clearance Adjusting Shim  
Courtesy of Toyota Motor Sales, U.S.A., Inc.

8) Using small screwdriver and magnet, remove adjusting shim. Using micrometer, measure thickness of removed adjusting shim. Using measured clearance and adjusting shim thickness, determine correct thickness of adjusting shim to be used. See Figs. 4 and 5.

9) Install proper adjusting shim with imprinted numbers on adjusting shim facing downward, toward valve lifter. Using SST "A", press downward on valve lifter and remove SST "B". Recheck valve clearance.

10) Apply sealant at front camshaft bearing cap-to-cylinder head surfaces where valve cover gasket seals. Install valve covers using NEW gaskets. Install upper timing belt cover.



Measured Clearance mm (in.)	Installed Shim Thickness mm (in.)	Shim No.	Thickness	Shim No.	Thickness	New shim thickness mm (in.)	Shim No.	Thickness
0.00 - 0.03 (0.000 - 0.008)	2.500 (0.0984)	1	2.500 (0.0984)	1	2.500 (0.0984)	2.500 (0.0984)	1	2.500 (0.0984)
0.03 - 0.04 (0.008 - 0.016)	2.550 (0.1000)	2	2.550 (0.1004)	2	2.550 (0.1004)	2.550 (0.1000)	2	2.550 (0.1000)
0.04 - 0.05 (0.016 - 0.024)	2.600 (0.1016)	3	2.600 (0.1020)	3	2.600 (0.1024)	2.600 (0.1016)	3	2.600 (0.1016)
0.05 - 0.06 (0.024 - 0.032)	2.650 (0.1032)	4	2.650 (0.1036)	4	2.650 (0.1040)	2.650 (0.1032)	4	2.650 (0.1032)
0.06 - 0.07 (0.032 - 0.040)	2.700 (0.1048)	5	2.700 (0.1052)	5	2.700 (0.1056)	2.700 (0.1048)	5	2.700 (0.1048)
0.07 - 0.08 (0.040 - 0.048)	2.750 (0.1064)	6	2.750 (0.1068)	6	2.750 (0.1072)	2.750 (0.1064)	6	2.750 (0.1064)
0.08 - 0.09 (0.048 - 0.056)	2.800 (0.1080)	7	2.800 (0.1084)	7	2.800 (0.1088)	2.800 (0.1080)	7	2.800 (0.1080)
0.09 - 0.10 (0.056 - 0.064)	2.850 (0.1096)	8	2.850 (0.1100)	8	2.850 (0.1104)	2.850 (0.1096)	8	2.850 (0.1096)
0.10 - 0.11 (0.064 - 0.072)	2.900 (0.1112)	9	2.900 (0.1116)	9	2.900 (0.1120)	2.900 (0.1112)	9	2.900 (0.1112)
0.11 - 0.12 (0.072 - 0.080)	2.950 (0.1128)	10	2.950 (0.1132)	10	2.950 (0.1136)	2.950 (0.1128)	10	2.950 (0.1128)
0.12 - 0.13 (0.080 - 0.088)	3.000 (0.1144)	11	3.000 (0.1148)	11	3.000 (0.1152)	3.000 (0.1144)	11	3.000 (0.1144)
0.13 - 0.14 (0.088 - 0.096)	3.050 (0.1160)	12	3.050 (0.1164)	12	3.050 (0.1168)	3.050 (0.1160)	12	3.050 (0.1160)
0.14 - 0.15 (0.096 - 0.104)	3.100 (0.1176)	13	3.100 (0.1180)	13	3.100 (0.1184)	3.100 (0.1176)	13	3.100 (0.1176)
0.15 - 0.16 (0.104 - 0.112)	3.150 (0.1192)	14	3.150 (0.1196)	14	3.150 (0.1200)	3.150 (0.1192)	14	3.150 (0.1192)
0.16 - 0.17 (0.112 - 0.120)	3.200 (0.1208)	15	3.200 (0.1212)	15	3.200 (0.1216)	3.200 (0.1208)	15	3.200 (0.1208)
0.17 - 0.18 (0.120 - 0.128)	3.250 (0.1224)	16	3.250 (0.1228)	16	3.250 (0.1232)	3.250 (0.1224)	16	3.250 (0.1224)
0.18 - 0.19 (0.128 - 0.136)	3.300 (0.1240)	17	3.300 (0.1244)	17	3.300 (0.1248)	3.300 (0.1240)	17	3.300 (0.1240)
0.19 - 0.20 (0.136 - 0.144)	3.350 (0.1256)	18	3.350 (0.1260)	18	3.350 (0.1264)	3.350 (0.1256)	18	3.350 (0.1256)
0.20 - 0.21 (0.144 - 0.152)	3.400 (0.1272)	19	3.400 (0.1276)	19	3.400 (0.1280)	3.400 (0.1272)	19	3.400 (0.1272)
0.21 - 0.22 (0.152 - 0.160)	3.450 (0.1288)	20	3.450 (0.1292)	20	3.450 (0.1296)	3.450 (0.1288)	20	3.450 (0.1288)
0.22 - 0.23 (0.160 - 0.168)	3.500 (0.1304)	21	3.500 (0.1308)	21	3.500 (0.1312)	3.500 (0.1304)	21	3.500 (0.1304)
0.23 - 0.24 (0.168 - 0.176)	3.550 (0.1320)	22	3.550 (0.1324)	22	3.550 (0.1328)	3.550 (0.1320)	22	3.550 (0.1320)
0.24 - 0.25 (0.176 - 0.184)	3.600 (0.1336)	23	3.600 (0.1340)	23	3.600 (0.1344)	3.600 (0.1336)	23	3.600 (0.1336)
0.25 - 0.26 (0.184 - 0.192)	3.650 (0.1352)	24	3.650 (0.1356)	24	3.650 (0.1360)	3.650 (0.1352)	24	3.650 (0.1352)
0.26 - 0.27 (0.192 - 0.200)	3.700 (0.1368)	25	3.700 (0.1372)	25	3.700 (0.1376)	3.700 (0.1368)	25	3.700 (0.1368)
0.27 - 0.28 (0.200 - 0.208)	3.750 (0.1384)	26	3.750 (0.1388)	26	3.750 (0.1392)	3.750 (0.1384)	26	3.750 (0.1384)
0.28 - 0.29 (0.208 - 0.216)	3.800 (0.1400)	27	3.800 (0.1404)	27	3.800 (0.1408)	3.800 (0.1400)	27	3.800 (0.1400)
0.29 - 0.30 (0.216 - 0.224)	3.850 (0.1416)	28	3.850 (0.1420)	28	3.850 (0.1424)	3.850 (0.1416)	28	3.850 (0.1416)
0.30 - 0.31 (0.224 - 0.232)	3.900 (0.1432)	29	3.900 (0.1436)	29	3.900 (0.1440)	3.900 (0.1432)	29	3.900 (0.1432)
0.31 - 0.32 (0.232 - 0.240)	3.950 (0.1448)	30	3.950 (0.1452)	30	3.950 (0.1456)	3.950 (0.1448)	30	3.950 (0.1448)
0.32 - 0.33 (0.240 - 0.248)	4.000 (0.1464)	31	4.000 (0.1468)	31	4.000 (0.1472)	4.000 (0.1464)	31	4.000 (0.1464)
0.33 - 0.34 (0.248 - 0.256)	4.050 (0.1480)	32	4.050 (0.1484)	32	4.050 (0.1488)	4.050 (0.1480)	32	4.050 (0.1480)
0.34 - 0.35 (0.256 - 0.264)	4.100 (0.1496)	33	4.100 (0.1500)	33	4.100 (0.1504)	4.100 (0.1496)	33	4.100 (0.1496)
0.35 - 0.36 (0.264 - 0.272)	4.150 (0.1512)	34	4.150 (0.1516)	34	4.150 (0.1520)	4.150 (0.1512)	34	4.150 (0.1512)
0.36 - 0.37 (0.272 - 0.280)	4.200 (0.1528)	35	4.200 (0.1532)	35	4.200 (0.1536)	4.200 (0.1528)	35	4.200 (0.1528)
0.37 - 0.38 (0.280 - 0.288)	4.250 (0.1544)	36	4.250 (0.1548)	36	4.250 (0.1552)	4.250 (0.1544)	36	4.250 (0.1544)
0.38 - 0.39 (0.288 - 0.296)	4.300 (0.1560)	37	4.300 (0.1564)	37	4.300 (0.1568)	4.300 (0.1560)	37	4.300 (0.1560)
0.39 - 0.40 (0.296 - 0.304)	4.350 (0.1576)	38	4.350 (0.1580)	38	4.350 (0.1584)	4.350 (0.1576)	38	4.350 (0.1576)
0.40 - 0.41 (0.304 - 0.312)	4.400 (0.1592)	39	4.400 (0.1596)	39	4.400 (0.1600)	4.400 (0.1592)	39	4.400 (0.1592)
0.41 - 0.42 (0.312 - 0.320)	4.450 (0.1608)	40	4.450 (0.1612)	40	4.450 (0.1616)	4.450 (0.1608)	40	4.450 (0.1608)
0.42 - 0.43 (0.320 - 0.328)	4.500 (0.1624)	41	4.500 (0.1628)	41	4.500 (0.1632)	4.500 (0.1624)	41	4.500 (0.1624)
0.43 - 0.44 (0.328 - 0.336)	4.550 (0.1640)	42	4.550 (0.1644)	42	4.550 (0.1648)	4.550 (0.1640)	42	4.550 (0.1640)
0.44 - 0.45 (0.336 - 0.344)	4.600 (0.1656)	43	4.600 (0.1660)	43	4.600 (0.1664)	4.600 (0.1656)	43	4.600 (0.1656)
0.45 - 0.46 (0.344 - 0.352)	4.650 (0.1672)	44	4.650 (0.1676)	44	4.650 (0.1680)	4.650 (0.1672)	44	4.650 (0.1672)
0.46 - 0.47 (0.352 - 0.360)	4.700 (0.1688)	45	4.700 (0.1692)	45	4.700 (0.1696)	4.700 (0.1688)	45	4.700 (0.1688)
0.47 - 0.48 (0.360 - 0.368)	4.750 (0.1704)	46	4.750 (0.1708)	46	4.750 (0.1712)	4.750 (0.1704)	46	4.750 (0.1704)
0.48 - 0.49 (0.368 - 0.376)	4.800 (0.1720)	47	4.800 (0.1724)	47	4.800 (0.1728)	4.800 (0.1720)	47	4.800 (0.1720)
0.49 - 0.50 (0.376 - 0.384)	4.850 (0.1736)	48	4.850 (0.1740)	48	4.850 (0.1744)	4.850 (0.1736)	48	4.850 (0.1736)
0.50 - 0.51 (0.384 - 0.392)	4.900 (0.1752)	49	4.900 (0.1756)	49	4.900 (0.1760)	4.900 (0.1752)	49	4.900 (0.1752)
0.51 - 0.52 (0.392 - 0.400)	4.950 (0.1768)	50	4.950 (0.1772)	50	4.950 (0.1776)	4.950 (0.1768)	50	4.950 (0.1768)
0.52 - 0.53 (0.400 - 0.408)	5.000 (0.1784)	51	5.000 (0.1788)	51	5.000 (0.1792)	5.000 (0.1784)	51	5.000 (0.1784)
0.53 - 0.54 (0.408 - 0.416)	5.050 (0.1800)	52	5.050 (0.1804)	52	5.050 (0.1808)	5.050 (0.1800)	52	5.050 (0.1800)
0.54 - 0.55 (0.416 - 0.424)	5.100 (0.1816)	53	5.100 (0.1820)	53	5.100 (0.1824)	5.100 (0.1816)	53	5.100 (0.1816)
0.55 - 0.56 (0.424 - 0.432)	5.150 (0.1832)	54	5.150 (0.1836)	54	5.150 (0.1840)	5.150 (0.1832)	54	5.150 (0.1832)
0.56 - 0.57 (0.432 - 0.440)	5.200 (0.1848)	55	5.200 (0.1852)	55	5.200 (0.1856)	5.200 (0.1848)	55	5.200 (0.1848)
0.57 - 0.58 (0.440 - 0.448)	5.250 (0.1864)	56	5.250 (0.1868)	56	5.250 (0.1872)	5.250 (0.1864)	56	5.250 (0.1864)
0.58 - 0.59 (0.448 - 0.456)	5.300 (0.1880)	57	5.300 (0.1884)	57	5.300 (0.1888)	5.300 (0.1880)	57	5.300 (0.1880)
0.59 - 0.60 (0.456 - 0.464)	5.350 (0.1896)	58	5.350 (0.1900)	58	5.350 (0.1904)	5.350 (0.1896)	58	5.350 (0.1896)
0.60 - 0.61 (0.464 - 0.472)	5.400 (0.1912)	59	5.400 (0.1916)	59	5.400 (0.1920)	5.400 (0.1912)	59	5.400 (0.1912)
0.61 - 0.62 (0.472 - 0.480)	5.450 (0.1928)	60	5.450 (0.1932)	60	5.450 (0.1936)	5.450 (0.1928)	60	5.450 (0.1928)
0.62 - 0.63 (0.480 - 0.488)	5.500 (0.1944)	61	5.500 (0.1948)	61	5.500 (0.1952)	5.500 (0.1944)	61	5.500 (0.1944)
0.63 - 0.64 (0.488 - 0.496)	5.550 (0.1960)	62	5.550 (0.1964)	62	5.550 (0.1968)	5.550 (0.1960)	62	5.550 (0.1960)
0.64 - 0.65 (0.496 - 0.504)	5.600 (0.1976)	63	5.600 (0.1980)	63	5.600 (0.1984)	5.600 (0.1976)	63	5.600 (0.1976)
0.65 - 0.66 (0.504 - 0.512)	5.650 (0.1992)	64	5.650 (0.1996)	64	5.650 (0.2000)	5.650 (0.1992)	64	5.650 (0.1992)
0.66 - 0.67 (0.512 - 0.520)	5.700 (0.2008)	65	5.700 (0.2012)	65	5.700 (0.2016)	5.700 (0.2008)	65	5.700 (0.2008)
0.67 - 0.68 (0.520 - 0.528)	5.750 (0.2024)	66	5.750 (0.2028)	66	5.750 (0.2032)	5.750 (0.2024)	66	5.750 (0.2024)
0.68 - 0.69 (0.528 - 0.536)	5.800 (0.2040)	67	5.800 (0.2044)	67	5.800 (0.2048)	5.800 (0.2040)	67	5.800 (0.2040)
0.69 - 0.70 (0.536 - 0.544)	5.850 (0.2056)	68	5.850 (0.2060)	68	5.850 (0.2064)	5.850 (0.2056)	68	5.850 (0.2056)
0.70 - 0.71 (0.544 - 0.552)	5.900 (0.2072)	69	5.900 (0.2076)	69	5.900 (0.2080)	5.900 (0.2072)	69	5.900 (0.2072)
0.71 - 0.72 (0.552 - 0.560)	5.950 (0.2088)	70	5.950 (0.2092)	70	5.950 (0.2096)	5.950 (0.2088)	70	5.950 (0.2088)
0.72 - 0.73 (0.560 - 0.568)	6.000 (0.2104)	71	6.000 (0.2108)	71	6.000 (0.2112)	6.000 (0.2104)	71	6.000 (0.2104)
0.73 - 0.74 (0.568 - 0.576)	6.050 (0.2120)	72	6.050 (0.2124)	72	6.050 (0.2128)	6.050 (0.2120)	72	6.050 (0.2120)
0.74 - 0.75 (0.576 - 0.584)	6.100 (0.2136)	73	6.100 (0.2140)	73	6.100 (0.2144)	6.100 (0.2136)	73	6.100 (0.2136)
0.75 - 0.76 (0.584 - 0.592)	6.150 (0.2152)	74	6.150 (0.2156)	74	6.150 (0.2160)	6.150 (0.2152)	74	6.150 (0.2152)
0.76 - 0.77 (0.592 - 0.600)	6.200 (0.2168)	75	6.200 (0.2172)	75	6.200 (0.2176)	6.200 (0.2168)	75	6.200 (0.2168)
0.77 - 0.78 (0.600 - 0.608)	6.250 (0.2184)	76	6.250 (0.2188)	76	6.250 (0.2192)	6.250 (0.2184)	76	6.250 (0.2184)
0.78 - 0.79 (0.608 - 0.616)	6.300 (0.2200)	77	6.300 (0.2204)	77	6.300 (0.2208)	6.300 (0.2200)	77	6.300 (0.2200)
0.79 - 0.80 (0.616 - 0.624)	6.350 (0.2216)	78	6.350 (0.2220)	78	6.350 (0.2224)	6.350 (0.2216)	78	6.350 (0.2216)
0.80 - 0.81 (0.624 - 0.632)	6.400 (0.2232)	79	6.400 (0.2236)	79	6.400 (0.2240)	6.400 (0.2232)	79	6.400 (0.2232)
0.81 - 0.82 (0.632 - 0.640)	6.450 (0.2248)	80	6.450 (0.2252)	80	6.450 (0.2256)	6.450 (0.2248)	80	6.450 (0.2248)
0.82 - 0.83 (0.640 - 0.648)	6.500 (0.2264)	81	6.500 (0.2268)	81	6.500 (0.2272)	6.500 (0.2264)	81	6.500 (0.2264)
0.83 - 0.84 (0.648 - 0.656)	6.550 (0.2280)	82	6.550 (0.2284)	82	6.550 (0.2288)	6.550 (0.2280)	82	6.550 (0.2280)
0.84 - 0.85 (0.656 - 0.664)	6.600 (0.2296)	83	6.600 (0.2300)	83	6.600 (0.2304)	6.600 (0.2296)	83	6.600 (0.2296)
0.85 - 0.86 (0.664 - 0.672)	6.650 (0.2312)	84	6.650 (0.2316)	84	6.650 (0.2320)	6.650 (0.2312)	84	6.650 (0.2312)
0.86 - 0.87 (0.672 - 0.680)	6.700 (0.2328)	85	6.700 (0.2332)	85	6.700 (0.2336)	6.700 (0.2328)	85	6.700 (0.2328)
0.87 - 0.88 (0.680 - 0.688)	6.750 (0.2344)	86	6.750 (0.2348)	86	6.750 (0.2352)	6.750 (0.2344)	86	6.750 (0.2344)
0.88 - 0.89 (0.688 - 0.696)	6.800 (0.2360)	87	6.800 (0.2364)	87	6.800 (0.2368)	6.800 (0.2360)	87	6.800 (0.2360)
0.89 - 0.90 (0.696 - 0.704)	6.850 (0.2376)	88	6.850 (0.2380)	88	6.850 (0.2384)	6.850 (0.2376)	88	6.850 (0.2376)
0.90 - 0.91 (0.704 - 0.712)	6.900 (0.							

1) Start and warm engine to normal operating temperature.  
Shut engine off.

2) On non-turbo models, connect timing light to spark plug wire on cylinder No. 1 (front cylinder at timing belt end of engine). Connect scan tester to data link connector No. 3. See Figs. 6 and 7. Scan tester is used to read engine RPM.

3) On turbo models, open cover located above the igniter. Connect timing light lead to Green wire and to battery. See Fig. 9. Igniter is located near driver's side strut tower. Connect tachometer to proper terminals of data link connector No. 1 located in engine compartment. See Figs. 6 and 7.

4) On all models, apply parking brake. Place transmission in Neutral. Start engine and maintain engine at 2500 RPM for 90 seconds and then allow engine to idle. Ensure idle speed is 650-750 RPM on non-turbo models or 600-700 on turbo models.

5) Install Jumper Wire (SST 09843-18020) between terminals TE1 and E1 of data link connector No. 1 located in engine compartment. See Fig. 8.

NOTE: Timing marks are located on front cover.

6) Ensure base timing is within specification at idle with transmission in Neutral, electric cooling fan off, A/C and all accessories off. See IGNITION TIMING table.

7) On non-turbo models, if base timing is not within specification, loosen distributor hold-down nut. Rotate distributor to obtain correct base timing. Tighten distributor hold-down nut.

8) On all models, remove jumper wire from data link connector No. 1. Ensure ECM controlled timing is within specification. See IGNITION TIMING table. Shut engine off. Remove jumper wire, tachometer or scan tester and timing light.

IGNITION TIMING TABLE (Degrees BTDC @ Idle) (1)

Application	(2) Base Timing	(3) ECM Controlled Timing
Non-Turbo .....	8-12 .....	7-19
Turbo .....	8-12 .....	10-20

- (1) - Check with engine at normal operating temperature, transmission in Neutral, parking brake applied, A/C and all accessories off.
- (2) - With Jumper Wire (SST 09843-18020) installed between terminals TE1 and E1 on data link connector No. 1.
- (3) - With jumper wire removed from data link connector No. 1.

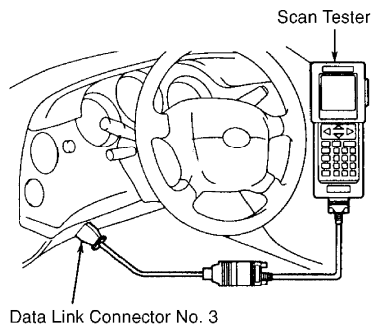

Fig. 6: Connecting Tachometer Or Scan Tester (Non-Turbo)  
Courtesy of Toyota Motor Sales, U.S.A., Inc.

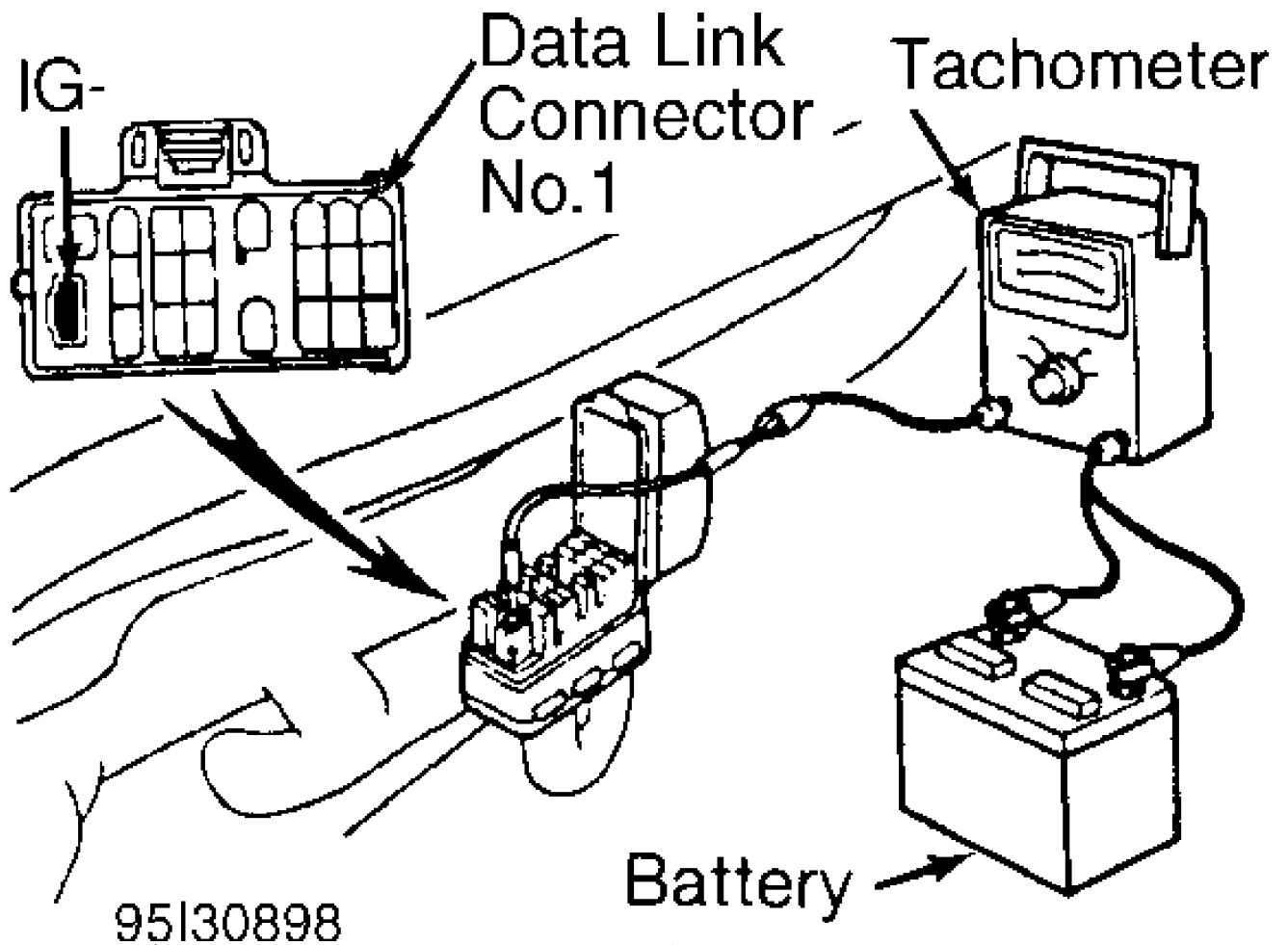
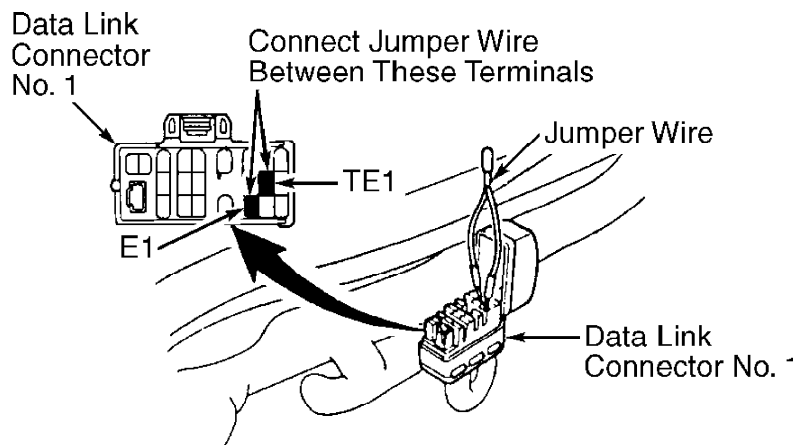
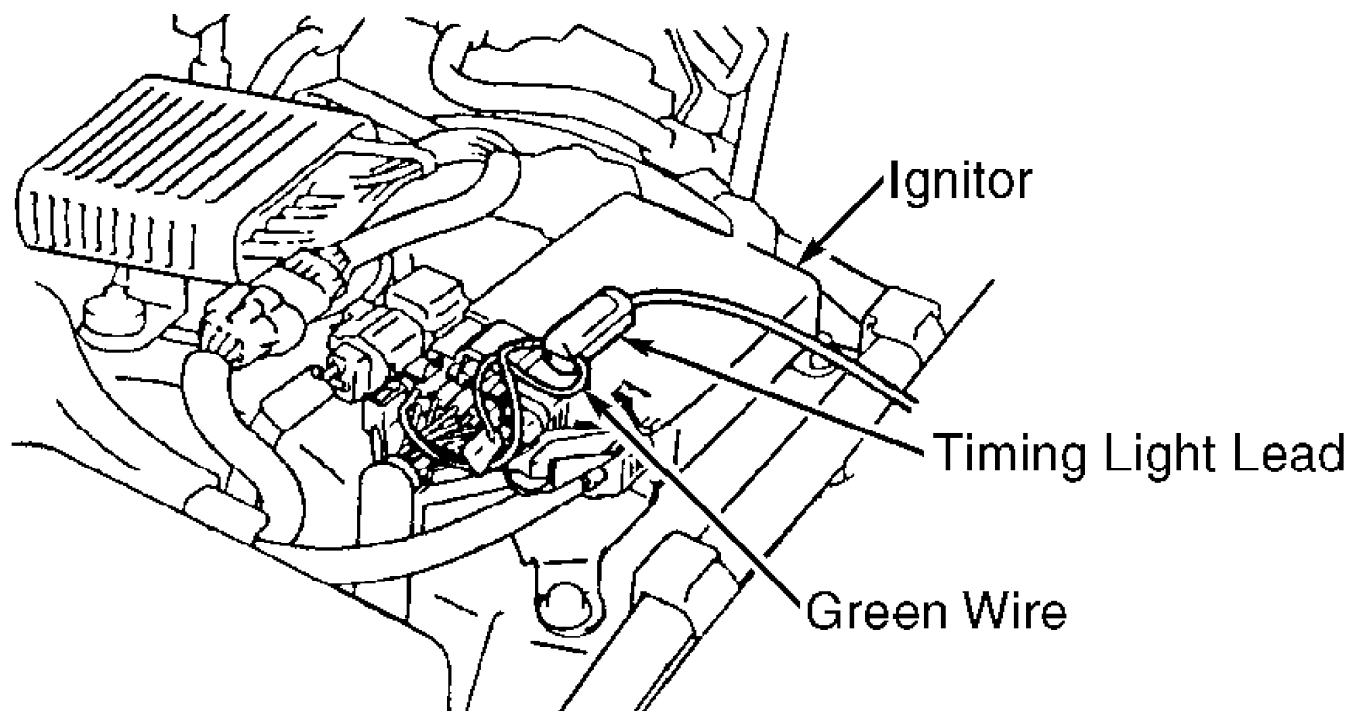

Fig. 7: Connecting Tachometer Or Scan Tester (Turbo)  
 Courtesy of Toyota Motor Sales, U.S.A., Inc.



95C30900  
 Fig. 8: Installing Jumper Wire Between DLC No. 1 Terminals  
 Courtesy of Toyota Motor Sales, U.S.A., Inc.



95D30901

Fig. 9: Connecting Timing Light (Turbo)  
 Courtesy of Toyota Motor Sales, U.S.A., Inc.

### IDLE SPEED & MIXTURE

NOTE: Mixture adjustment is not possible on any model.

NOTE: Check and adjust idle speed with air cleaner installed, all air intake system hoses and vacuum lines connected, electronic fuel injection system wiring connectors tight, transmission in Neutral, ignition timing properly set, electric cooling fan off (if equipped), A/C and all accessories off, and engine at normal operating temperature.

1) Start and warm engine to normal operating temperature.  
 Shut engine off.

2) On non-turbo models, connect scan tester to data link connector No. 3. See Figs. 6-7. Scan tester is used to read engine RPM.

CAUTION: Some tachometers may not be compatible with ignition system. Consult tachometer manufacturer before connecting tachometer to system. To avoid possible damage to igniter and/or coil, DO NOT allow tachometer terminal to become grounded.

3) On turbo models, connect tachometer to proper terminals of data link connector No. 1 located in engine compartment. See Figs. 6-7.

4) On all models, apply parking brake. Place transmission in Neutral. Start engine and maintain engine at 2500 RPM for 90 seconds and then allow engine to idle. Ensure idle speed is within specification. See IDLE SPEED SPECIFICATIONS table.

5) If idle speed is not within specification, check Idle Air Control (IAC) valve, wiring and Electronic Control Module (ECM). See

IDLE CONTROL SYSTEM in appropriate SYSTEM & COMPONENT TESTING article.  
 Shut engine off. Remove scan tester or tachometer.

IDLE SPEED SPECIFICATIONS TABLE (1)

Application	RPM
Non-Turbo .....	650-750
Turbo .....	600-700

(1) - Check with engine at normal operating temperature, transmission in Neutral, parking brake applied, ignition timing properly set, and with A/C and all accessories off.

### THROTTLE POSITION SENSOR

NOTE: Supra Turbo contains a main throttle position sensor and a sub-throttle position sensor on throttle body. See Figs. 10 and 11. Following procedure is for main throttle position sensor. For adjustment of sub-throttle position sensor, see SUB-THROTTLE POSITION SENSOR.

1) Disconnect electrical connector from Throttle Position (TP) sensor. Loosen TP sensor mounting screws. Connect ohmmeter between terminals IDL and E2. See Figs. 10 and 11.

2) Apply vacuum to throttle opener. To set initial clearance, insert proper thickness feeler gauge between throttle stop screw and throttle lever. See THROTTLE POSITION SENSOR ADJUSTMENT table.

3) With ohmmeter showing no continuity, rotate TP sensor clockwise until continuity exists. Tighten TP sensor mounting screws. Using specified feeler gauge, recheck for continuity and no continuity at adjusted clearances. Disconnect ohmmeter. Install electrical connector on TP sensor.

THROTTLE POSITION SENSOR ADJUSTMENT TABLE

Application	Initial Clearance	Adjusted Clearance	Ohmmeter Reading
Turbo (1) (2) .....	.026 (.65)	.021 (.54) .....	Continuity
		.028 (.70) ..	No Continuity
Non-Turbo (1) ....	.020 (.50)	.016 (.40) .....	Continuity
		.024 (.60) ..	No Continuity

(1) - Apply vacuum to throttle opener before checking TP sensor adjustment.

(2) - Turbo models contain a main throttle position sensor and a sub-throttle position sensor on throttle body. See Fig. 12. Procedure is for main throttle position sensor. For adjustment of sub-throttle position sensor, see SUB-THROTTLE POSITION SENSOR.

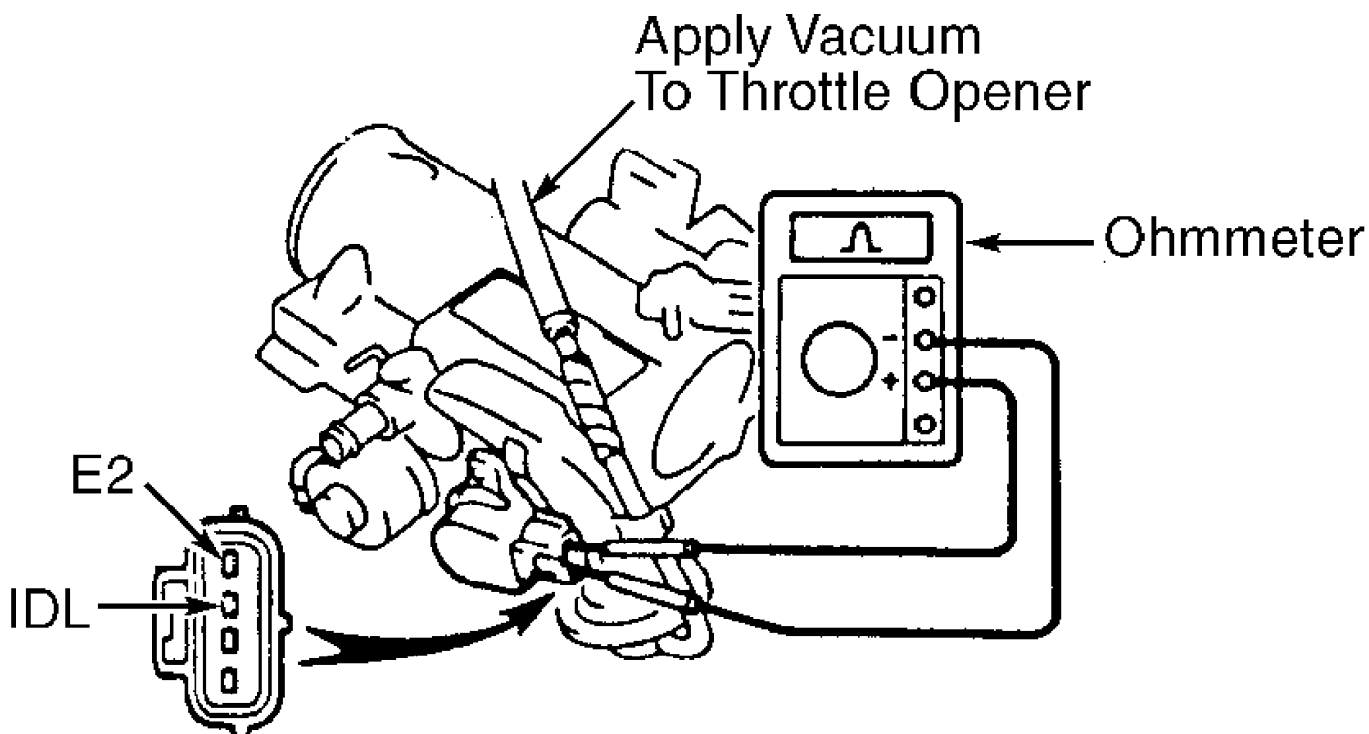

95D30919

Fig. 10: Adjusting Throttle Position Sensor (Non-Turbo)  
 Courtesy of Toyota Motor Sales, U.S.A., Inc.

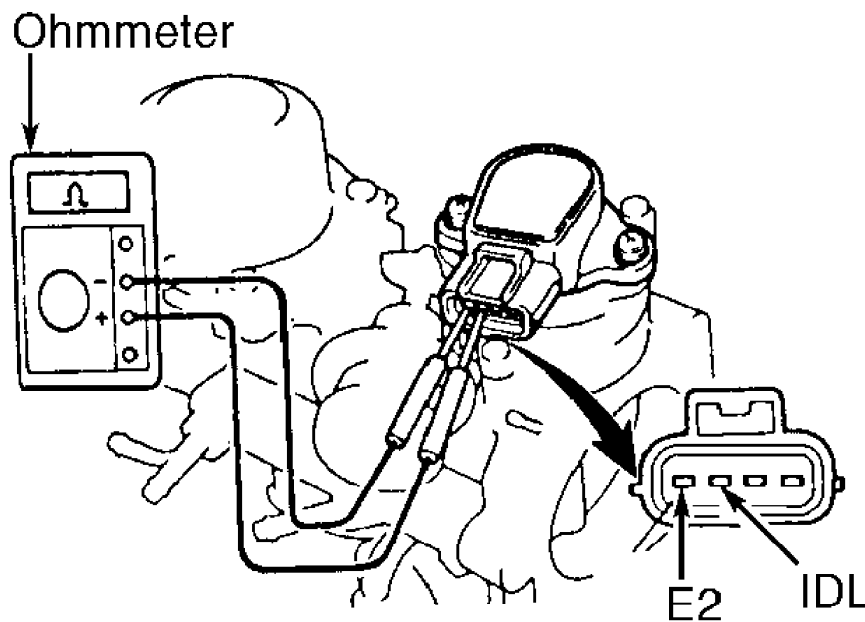

95J30923

Fig. 11: Adjusting Throttle Position Sensor (Turbo)  
 Courtesy of Toyota Motor Sales, U.S.A., Inc.

**SUB-THROTTLE POSITION SENSOR**

- 1) Remove screws and sub-throttle actuator. See Fig. 12. Disconnect electrical connector from sub-throttle position sensor.
- 2) Ensure no clearance exists between throttle stop screw and throttle valve gear with sub-throttle valve fully closed. Perform STEP 1. See Fig. 13.
- 3) Place sub-throttle valve in fully closed position. Loosen sub-throttle position sensor mounting screws. Connect ohmmeter between terminals IDL and E2. Perform STEP 2. See Fig. 13.
- 4) To set initial clearance, insert .018" (.45 mm) feeler gauge between throttle stop screw and throttle valve gear. Perform STEP 3. See Fig. 13.
- 5) With ohmmeter showing no continuity, rotate sub-throttle position sensor clockwise until continuity exists. Tighten sub-throttle position sensor mounting screws.
- 6) Remove feeler gauge. Insert a .016" (.41 mm) feeler gauge. Ensure continuity still exists. Remove feeler gauge. Insert a .019" (.48 mm) feeler gauge. Ensure continuity no longer exists. Reinstall sub-throttle actuator. Install electrical connector on sub-throttle position sensor.

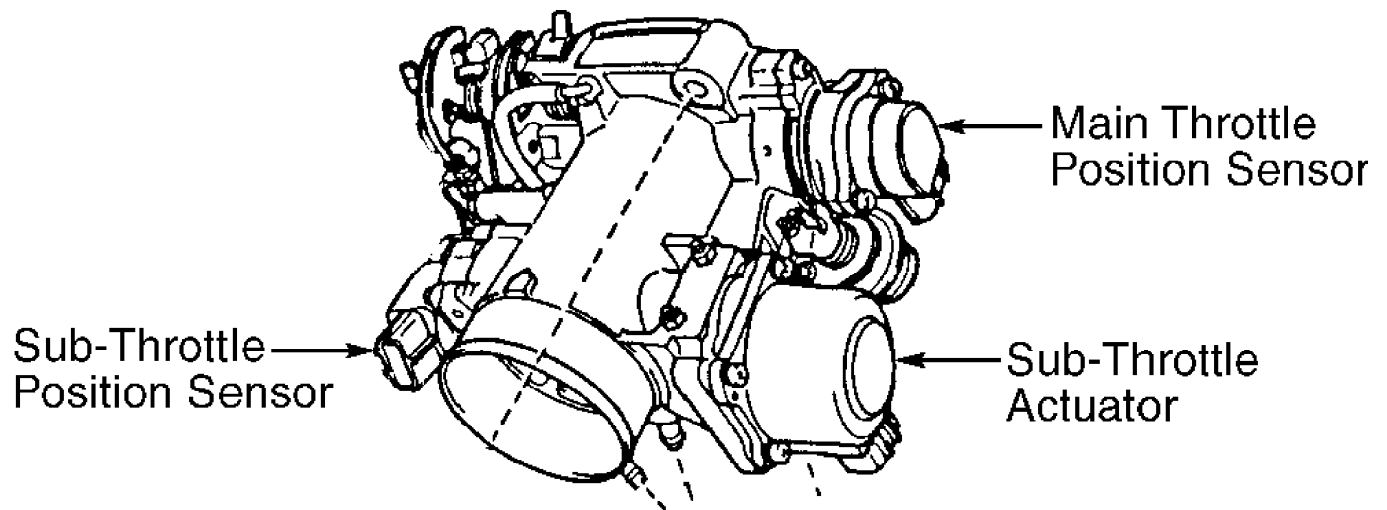

93G78291

Fig. 12: Sub-Throttle Actuator & Throttle Position Sensor ID (Turbo)  
Courtesy of Toyota Motor Sales, U.S.A., Inc.

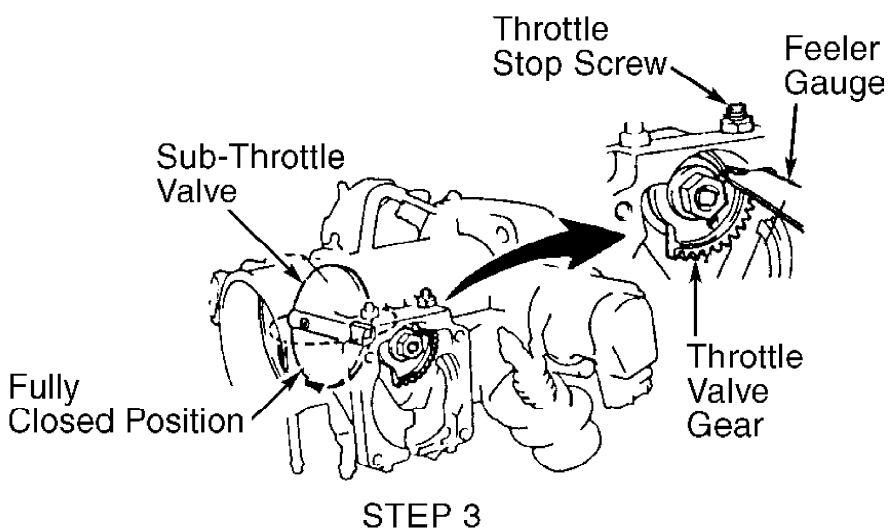
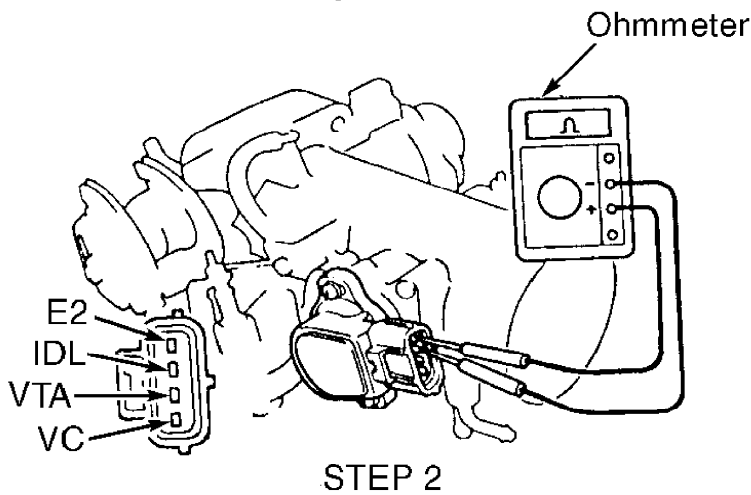
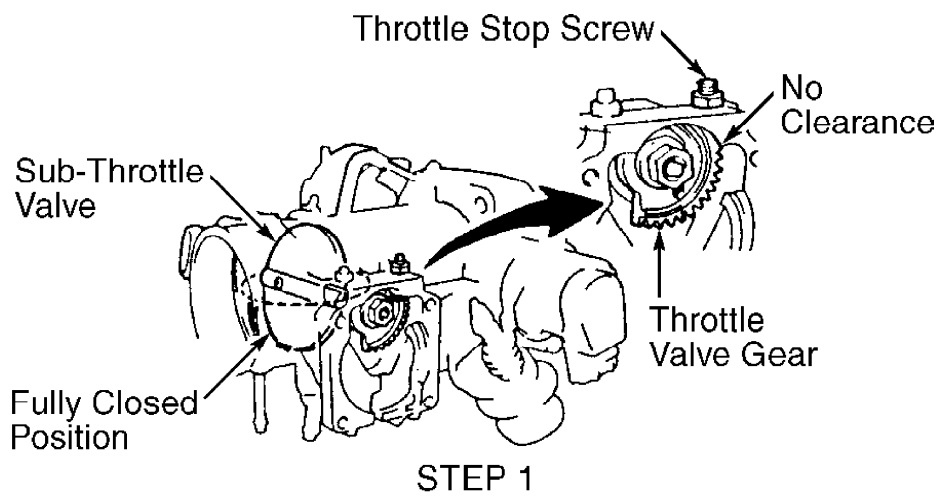

95A30924  
 Fig. 13: Adjusting Sub-Throttle Position Sensor (Turbo)  
 Courtesy of Toyota Motor Sales, U.S.A., Inc.

**DASHPOT & THROTTLE VALVE OPENER CONTROL SYSTEM**

For testing and adjustment procedures, see THROTTLE CONTROLS  
in SYSTEM & COMPONENT TESTING article.